

INSTALLATION AND SERVICE MANUAL

LANCER

FOR

COUNTER ELECTRIC DISPENSER

LANCER SERIES 500

SPECIFICATIONS

DIMENSION

Width	10 3/8 inches	(264 mm)
Depth	25 1/4 inches	(641 mm)
Height (without legs)	22 15/16 inches	(583 mm)

WEIGHT

Shipping	108 pounds	(49.0 kg)
Empty	89 pounds	(40.4 kg)
Operating	125 pounds	(55.4 kg)

Please refer to the Lancer web site (www.lancercorp.com) for information relating to Lancer Installation and Service Manuals, Instruction Sheets, Technical Bulletins, Service Bulletins, etc.

WATER REQUIREMENTS

CAUTION

IF WATER SOURCE EXCEEDS 60 PSIG (4.22 KG/CM²), A RECOMMENDED WATER REGULATOR ASSEMBLY (PN 18-0253) MUST BE USED TO LIMIT WATER PRESSURE TO 60 PSIG (4.22 KG/CM²). FAILURE TO USE REGULATOR WILL RESULT IN IMPROPER PERFORMANCE OF DISPENSER.

Minimum flowing pressure of 35 PSIG (2.46 kg/cm², 2.41 BAR)

Maximum static pressure of 60 PSIG (4.22 kg/cm², 4.14 BAR)

CARBON DIOXIDE (CO₂) REQUIREMENTS

Minimum pressure of 70 PSIG (4.92 kg/cm², 4.83 BAR)

Maximum pressure of 80 PSIG (5.62 kg/cm², 5.52 BAR)

ICE BANK WEIGHT

16 pounds (17.26 kg)

WATER BATH CAPACITY

5.1 gallons (19.3 liters)

COMPRESSOR

¼ HP Tecumseh, 115V/60Hz

AGITATOR MOTOR

15W, 115V

CONDENSER FAN MOTOR

9W, 115V

ICE BANK CONTROL

Lancer Electronic Ice Bank Control

TRANSFORMER

Basler, 115V (Primary)/24V (Secondary)

Optional 230V/50Hz and 240V/60Hz systems available.

DRINK CAPACITY

57 – 12 ounce drinks under 40°F (4.4°C) at four (4) drinks per minute with 75°F (23.9°C) ambient, inlet water, and inlet syrup.

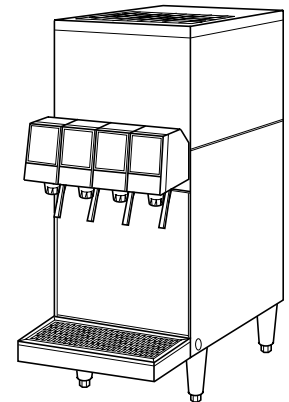

This manual is an initial issue

LANCER

6655 LANCER BLVD. • SAN ANTONIO, TEXAS 78219 USA • (210) 310-7000

FAX SALES

• NORTH AMERICA – 210-310-7245 • INTERNATIONAL SALES – 210-310-7242 • CUSTOMER SERVICE – 210-310-7242 •
• LATIN AMERICA – 210-310-7245 • EUROPE – 32-2-755-2399 • PACIFIC – 61-8-8268-1978 •

FAX ENGINEERING: • 210-310-7096

"Lancer" is the registered trademark of Lancer • Copyright — 2000 by Lancer, all rights reserved.

REV: 04/20/00
P.N. 28-0449

TABLE OF CONTENTS

SPECIFICATIONS	COVER
TABLE OF CONTENTS	1
1. INSTALLATION	1
1.1 RECEIVING.....	1
1.2 UNPACKING	2
1.3 INSTALLATION	2
1.4 CONNECTING TO ELECTRICAL POWER	2
1.5 CONNECTING SUPPLY LINES TO SOURCES	2
2. SCHEDULED MAINTENANCE	3
2.1 DAILY	3
2.2 WEEKLY.....	3
2.3 MONTHLY	3
2.4 EVERY SIX MONTHS.....	3
2.5 YEARLY.....	3
3. DISPENSER CLEANING AND SANITIZING	3
3.1 AMBIENT PROCESS	3
3.2 VALVES.....	4
4. TROUBLESHOOTING.....	4
4.1 WATER LEAKAGE AROUND NOZZLE	4
4.2 LEAKAGE BETWEEN UPPER AND LOWER BODIES.....	4
4.3 MISCELLANEOUS LEAKAGE	4
4.4 INSUFFICIENT WATER FLOW.....	4
4.5 INSUFFICIENT SYRUP FLOW.....	5
4.6 ERRATIC RATIO	5
4.7 NO PRODUCT DISPENSED	5
4.8 WATER ONLY DISPENSED; NO SYRUP; OR SYRUP ONLY DISPENSED, NO WATER.....	5
4.9 VALVE WILL NOT SHUT OFF	5
4.10 EXCESSIVE FOAMING	5
4.11 COMPRESSOR DOES NOT START (NO HUM), BUT CONDENSER FAN MOTOR RUNS.....	6
4.12 COMPRESSOR STARTS AND CONTINUES TO RUN UNTIL FREEZE UP AND WILL NOT CUT OFF	6
4.13 COMPRESSOR DOES NOT START BUT HUMS	6
4.14 COMPRESSOR STARTS BUT DOES NOT SWITCH OFF START WINDING	6
4.15 COMPRESSOR STARTS AND RUNS A SHORT TIME BUT SHUTS OFF ON OVERLOAD.....	6
4.16 COMPRESSOR AND CONDENSER FAN MOTOR WILL NOT START AFTER FIVE (5) MINUTE POWER OFF DELAY (LANCER EIBC EXPORT ONLY)	6
4.17 COMPRESSOR AND CONDENSER FAN MOTOR WILL NOT START AFTER FIVE (5) MINUTE POWER OFF DELAY (LANCER EIBC USA ONLY).....	6
4.18 WARM DRINKS.....	6
5. ILLUSTRATIONS, PARTS LISTINGS, AND WIRING DIAGRAMS	7
5.1 500 CED WIRING DIAGRAM, 220-240V/50-60HZ, LANCER ELECTRONIC ICE BANK CONTROL (INTERNATIONAL ONLY).....	7
5.2 500 CED WIRING DIAGRAM, 115V/60HZ, LANCER ELECTRONIC ICE BANK CONTROL AND CONTROL HOUSING CONNECTIONS (USA ONLY).....	8
5.3 CABINET ASSEMBLY.....	9-10
5.4 COMPRESSOR DECK ASSEMBLY	11-12

1. INSTALLATION

1.1 RECEIVING

Each unit is completely tested under operating conditions and thoroughly inspected before shipment. At the time of shipment, the carrier accepts the unit and any claim for damage must be made with the carrier. Upon receiving unit(s) from the delivering carrier, carefully inspect carton for visible indication of damage. If damage exists, have carrier note same on bill of lading and file a claim with the carrier.

1.2 UNPACKING

- A. Remove cup rest by lifting out.
- B. Remove splash plate by pulling forward at the bottom. Drip tray can be removed before removing splash plate.
- C. Remove drip tray by lifting out.
- D. Remove shipping base. **DO NOT LAY UNIT ON ITS SIDE OR BACK. DO NOT USE DRIP TRAY FRAME FOR A HANDLE.**

NOTE

If unit is to be transported, it is advisable to leave unit secured to plywood shipping base.

- E. Inspect unit for concealed damage. If damage exists, notify delivering carrier note and file a claim against the carrier.

1.3 INSTALLATION

The dispenser is designed to sit on a flat, supported surface *capable of supporting a minimum weight of 200 pounds (90.7 kg)*. It may be either counter or leg mounted. When the dispenser is to be permanently bolted to the counter top, seal dispenser base to counter top with a silicone sealant which provides a smooth and easily cleanable bond to the counter.

NOTE

NSF listed units must be sealed to the counter or have four (4) inch legs installed.

WARNING

FAILURE TO MAINTAIN PROPER AIR CLEARANCE WILL CAUSE THE COMPRESSOR TO OVERHEAT AND WILL RESULT IN PREMATURE COMPONENT FAILURE.

Locate dispenser to allow approximately 15 inches (380 mm) of unobstructed space above and six (6) inches (152 mm) of unobstructed space in back of the unit for proper air circulation and removal of bonnet. Air is drawn in through the back grill and is exhausted out the top grill.

- A. Position dispenser on counter.
- B. Remove bonnet from the dispenser.
- C. Remove insulation strip from in front of refrigeration deck. Fill tank with water until water comes out of overflow tube. Replace insulation. Use bottled water where a water problem exists.

1.4 CONNECTING TO ELECTRICAL POWER

WARNING

THIS UNIT MUST BE PROPERLY ELECTRICALLY GROUNDED TO AVOID POSSIBLE FATAL ELECTRICAL SHOCK OR SERIOUS INJURY TO THE OPERATOR. THE POWER CORD IS PROVIDED WITH A THREE PRONG GROUNDED PLUG. IF A THREE-HOLE GROUNDED ELECTRICAL OUTLET IS NOT AVAILABLE, USE AN APPROVED METHOD TO GROUND THE UNIT.

DO NOT USE EXTENSION CORDS WITH THIS UNIT. DO NOT "GANG" TOGETHER WITH OTHER ELECTRICAL DEVICES ON THE SAME OUTLET.

- A. Check the dispenser serial number plate for unit's correct electrical requirements. Do not plug into electrical outlet unless unit electrical configuration, located on serial plate, agrees with local available power supply.
- B. Route the power supply cord to a grounded electrical outlet of the proper voltage and amperage rating, and plug in the unit. This will turn on the refrigeration system and allow it to start cooling and allow ice bank to form while completing installation. Approximately four (4) hours are required to form a full ice bank.

NOTE

Units equipped with an electronic ice bank control contain a five (5) minute delay. Compressor and fan motor will not begin running until five (5) minutes after the unit is energized.

1.5 CONNECTING SUPPLY LINES TO SOURCES

- A. Connect free end of plain water lines to water supply [*must be 35 PSI (2.4 BAR) or more*].

- B. Mark both ends of product and water lines and route to dispenser. Flush lines to be sure each is clean. Failure to do so may result in clogging of valve(s), resulting in improper operation. Connect lines to dispenser and secure using Oetiker clamps.
- C. Route drain tube to dispenser.
- D. Connect drain tube to drip tray and install on dispenser.
- E. Turn on water supply.
- F. Open all dispenser valves until air is bled from system.
- G. Actuate valve until a smooth flow of water is obtained.
- H. Check for leaks.
- I. Connect free ends of product lines to proper tanks or bag-in-box.
- J. Check for syrup leaks.
- K. Adjust the water flow.
- L. Install splash plate on dispenser.
- M. Install cup rest on dispenser.
- N. Replace bonnet on dispenser.

2. SCHEDULED MAINTENANCE

2.1 DAILY

- A. Remove the nozzle and diffuser from each valve and rinse well in warm water. *Do NOT use soap or detergent. This will cause foaming and off taste in finished product.*
- B. Remove the cup rest and wash in warm soapy water.
- C. Pour warm soapy water into the drip tray and wipe with a clean cloth.
- D. With a clean cloth and warm water, wipe off all of the unit's exterior surfaces. **DO NOT USE ABRASIVE SOAPS OR STRONG DETERGENTS.**
- E. Replace the cup rest, valve diffusers, and valve nozzles.

2.2 WEEKLY

- A. Taste each product for off tastes and/or brix changes.
- B. Remove the bonnet and check the level of water in the water bath. Replenish as required, and replace the bonnet.

2.3 MONTHLY

- A. Unplug the dispenser from power source.
- B. Remove the bonnet and clean the dirt from the condenser using a soft brush.
- C. Replace the bonnet and plug in the unit.

2.4 EVERY SIX MONTHS

- A. Clean and sanitize the unit using the appropriate procedures outlined in Section 3 of this manual.

2.5 YEARLY

- A. Clean water bath interior, including evaporator coils and refrigeration components.
- B. Clean the entire exterior of the unit.
- C. Sanitize syrup lines.

3. DISPENSER CLEANING AND SANITIZING

3.1 AMBIENT PROCESS

- A. The ambient process is the most common method for cleaning and sanitizing dispenser equipment. The detergent should be caustic-based and the sanitizer should be low pH (7.0) chloride solution.
- B. Disconnect syrup containers and remove product from tubing by purging with carbon dioxide.
- C. Rinse the lines and fittings with clean, room temperature water to remove all traces of residual product.
- D. Fill lines with a caustic-based (low-sudsing, non-perfumed, and easily rinsed) detergent solution. The solution should be prepared in accordance with the manufacturer's recommendations, but should be at least two (2) percent sodium hydroxide. Make sure the lines are completely filled and allow to stand for at least ten (10) minutes.
- E. Flush the detergent solution from the lines with clean water. Continue rinsing until testing with

phenolphthalein shows that the rinse water is free of residual detergent.

- F. Fill the lines with a low pH (7.0) chlorine solution containing at least 50 parts per million (PPM) (50 mg/L) available chlorine. Make sure that lines are completely filled and allow to stand for ten (10) minutes.
- G. Reconnect syrup containers and ready Unit for operation.

WARNING

REMOVE SANITIZING SOLUTION FROM DISPENSER AS INSTRUCTED. RESIDUAL SANITIZING SOLUTION LEFT IN SYSTEM COULD CREATE HEALTH HAZARD.

- H. Draw drinks to refill lines and flush the chlorine solution from the dispenser.

NOTE

Please note that a fresh water rinse cannot follow sanitization of equipment. Purge only with the end use product. *This is an NSF requirement.*

- I. Taste the beverage to verify that there is no off taste.

3.2 VALVES

- A. Valves may be cleaned and sanitized in the same manner
 - 1. Remove cover and disconnect power so not to activate the valve while cleaning. Remove nozzle and diffuser. Wash these parts in cleaning solution, then immerse them in a bath of sanitizing solution for 15 minutes.
 - 2. Visually inspect around nozzle area for syrup residue. This area may be cleaned with warm water and cloth or with the nozzle brush supplied. Wipe off dispensing lever.
 - 3. Wearing sanitary gloves, remove, drain and air dry the nozzle and diffuser.
 - 4. Wearing sanitary gloves, replace diffuser and twist nozzle into place.
 - 5. Draw drinks to flush the chlorine solution from the valves.

NOTE

Please note that a fresh water rinse cannot follow sanitization of equipment. Purge only with the end use product. *This is an NSF requirement.*

- 6. Taste the beverage to verify that there is no off taste.
- 7. Connect power and replace cover. Valve is ready for operation.

4. TROUBLESHOOTING

<u>TROUBLE</u>	<u>CAUSE</u>	<u>REMEDY</u>
4.1 Water leakage around nozzle.	A. Damaged or improperly installed o-ring above diffuser.	A. If damaged, replace. If improperly installed, adjust.
4.2 Leakage between upper and lower valve bodies.	A. Gap between upper and lower valve bodies. B. Worn or damaged paddle arm assemblies.	A. Tighten all six (6) retaining screws. B. Replace paddle arm assemblies.
4.3 Miscellaneous leakage.	A. Gap between parts. B. Damaged or improperly installed o-rings.	A. Tighten appropriate retaining screws. B. Replace or adjust appropriate o-rings.
4.4 Insufficient water flow.	A. Insufficient incoming supply water pressure. B. Shutoff on mounting block not fully open. C. Foreign debris in water flow control.	A. Verify incoming supply water pressure is a minimum of 35 PSI (2.4 bar). B. Open shutoff fully. C. Remove water flow control from upper body and clean out any foreign material to ensure smooth free spool movement.

TROUBLE	CAUSE	REMEDY
4.5 Insufficient syrup flow.	<p>A. Insufficient CO₂ pressure to BIB pumps.</p> <p>B. Shutoff on mounting block not fully open.</p> <p>C. Foreign debris in syrup flow control.</p>	<p>A. Adjust CO₂ pressure to 80 PSI (5.5 bar) [minimum 70 PSI (4.8 bar)] for BIB pumps.</p> <p>B. Open shutoff fully.</p> <p>C. Remove syrup flow control from upper body and clean out any foreign material to ensure smooth free spool movement.</p>
4.6 Erratic ratio.	<p>A. Incoming water and/or syrup supply not at minimum flowing pressure.</p> <p>B. Foreign debris in water and/or syrup flow controls.</p>	<p>A. Check pressure and adjust.</p> <p>B. Remove flow controls from upper body and clean out any foreign material to ensure smooth free spool movement.</p>
4.7 No product dispensed.	<p>A. Water and syrup shutoffs on mounting block not fully open.</p> <p>B. The key switch on an electric valve is in the OFF position.</p> <p>C. Cup lever arm or ID panel actuator on electric valve is not actuating the switch.</p> <p>D. Electric current not reaching Valve.</p> <p>E. Improper or inadequate water or syrup supply.</p>	<p>A. Open shutoffs fully.</p> <p>B. Turn key switch to ON position.</p> <p>C. Repair.</p> <p>D. Check electric current supplied to valve. If current is adequate, check solenoid coil and switch, and replace if necessary.</p> <p>E. Remove valve from mounting block and open shutoffs slightly and check water and syrup flow. If no flow, check dispenser for freeze-up or other problems.</p>
4.8 Water only dispensed; no syrup; or syrup only dispensed, no water.	<p>A. Water or syrup shutoff on mounting block not fully open.</p> <p>B. Improper or inadequate water or syrup flow.</p> <p>C. Kinked line.</p>	<p>A. Open shutoff fully.</p> <p>B. Remove valve from mounting block, open shutoffs slightly and check water and syrup flow. If no flow check dispenser for freeze-up or other problems. Ensure BIB connection is engaged.</p> <p>C. Remove kink or replace line.</p>
4.9 Valve will not shut off.	<p>A. Cup lever may be sticking or binding.</p> <p>B. Switch not actuating freely.</p> <p>C. Solenoid armature not returning to bottom position.</p>	<p>A. Correct or replace lever.</p> <p>B. Check switch for free actuation.</p> <p>C. Replace defective armature or spring.</p>
4.10 Excessive foaming.	<p>A. Incoming water or syrup temperature too high.</p> <p>B. Water flow rate too high.</p> <p>C. Nozzle and diffuser not properly installed.</p> <p>D. Nozzle and diffuser not clean.</p> <p>E. Air in BIB lines.</p> <p>F. Poor quality ice.</p> <p>G. High beverage temperature.</p>	<p>A. Correct prior to dispenser. Consider larger dispenser or precooler.</p> <p>B. Readjust and reset ratio. Refer to Sections 1.5.K and 1.5.L.</p> <p>C. Remove and reinstall properly.</p> <p>D. Remove and clean.</p> <p>E. Bleed air from BIB lines.</p> <p>F. Check quality of ice used in drink.</p> <p>G. Check refrigeration system.</p>

TROUBLE	CAUSE	REMEDY
4.11 Compressor does not start (no hum), but condenser fan motor runs.	A. Compressor relay or overload malfunctioning. B. Inadequate voltage. C. Incorrect wiring. D. Compressor malfunctioning.	A. Replace compressor relay or overload. B. Measure voltage across common and run terminal on compressor. Voltage must not drop below 90% of rated voltage. C. Refer to wiring diagram and correct. D. Replace compressor.
4.12 Compressor starts and continues to run until freeze up and will not cut off.	A. Ice bank control failure. B. Incorrect wiring. C. Probe shorted.	A. Replace ice bank control. B. Refer to wiring diagram and correct. C. Check probe for foreign material or damage.
4.13 Compressor does not start but hums.	A. Inadequate voltage. B. Incorrect wiring. C. Starting relay malfunctioning. D. Compressor malfunctioning.	A. Measure voltage across common and run terminal on compressor. Voltage must not drop below 90% of rated voltage. B. Refer to wiring diagram and correct. C. Replace starting relay. Be sure to use correct relay. Failure to use correct relay will cause compressor failure. D. Replace compressor.
4.14 Compressor starts but does not switch off start winding (will run for only a few seconds before internal overload switches compressor off).	A. Inadequate voltage. B. Incorrect wiring. C. Starting relay malfunctioning.	A. Measure voltage across common and run terminal on compressor. B. Refer to wiring diagram and correct. C. Replace starting relay. Be sure to use correct relay. Failure to use correct relay will cause compressor failure.
4.15 Compressor starts and runs a short time but shuts off on overload.	A. Dirty condenser. B. Insufficient or blocked air flow. C. Inadequate voltage. D. Incorrect wiring. E. Defective condenser fan motor. F. Refrigerant leak. G. Compressor malfunctioning.	A. Clean the condenser. B. Remove all obstructions and allow for minimum clearances of 15 inches (380 mm) over top. C. Measure voltage across common and run terminal on compressor. Voltage must not drop below 90% of rated voltage. D. Refer to wiring diagram and correct. E. Replace condenser fan motor. F. Repair and recharge. G. Replace compressor.
4.16 Compressor and Condenser Fan Motor will not start after five (5) minute Power Off delay (Lancer EIBC Export only).	A. Transformer tripped. B. Relay will not turn on compressor. C. Probe unplugged.	A. Reset transformer. B. Failed relay. Replace Control Board. C. Check probe connection at PCB.
4.17 Compressor and Condenser Fan Motor will not start after five (5) minute Power Off delay (Lancer EIBC, USA Only).	A. Improper Wiring. B. Probe unplugged. C. Damaged electronics.	A. Check Power Indicator Lamp; check wiring per Wiring Diagram. B. Check Probe connection at PCB. C. Replace Control.
4.18 Warm drinks.	A. Restricted airflow. B. Dispenser connected to hot water supply.	A. Check clearances around sides, top, and inlet of unit. Remove objects blocking airflow through grill. B. Switch to cold water supply.

(Section 4.18 continued on next page)

TROUBLE	CAUSE	REMEDY
<i>(Section 4.18 continued from previous page)</i>		
	C. Refrigeration system not running.	C. Refer to Sections 4.11 - 4.15.
	D. Refrigerant leak.	D. Repair and recharge.
	E. Condenser fan motor not working.	E. Replace condenser fan motor.
	F. Dirty condenser.	F. Clean condenser.
	G. Dispenser capacity exceeded.	G. Add pre-chiller.

5. ILLUSTRATIONS, PARTS LISTINGS, AND WIRING DIAGRAMS

5.1 500 CED WIRING DIAGRAM, 220-240V/50-60HZ, LANCER ELECTRONIC ICE BANK CONTROL (INTERNATIONAL ONLY)

IMPORTANT

WHEN STARTING UNIT OR IF CURRENT IS INTERRUPTED, THERE IS A FIVE (5) MINUTE DELAY BEFORE THE COMPRESSOR/FAN STARTS.

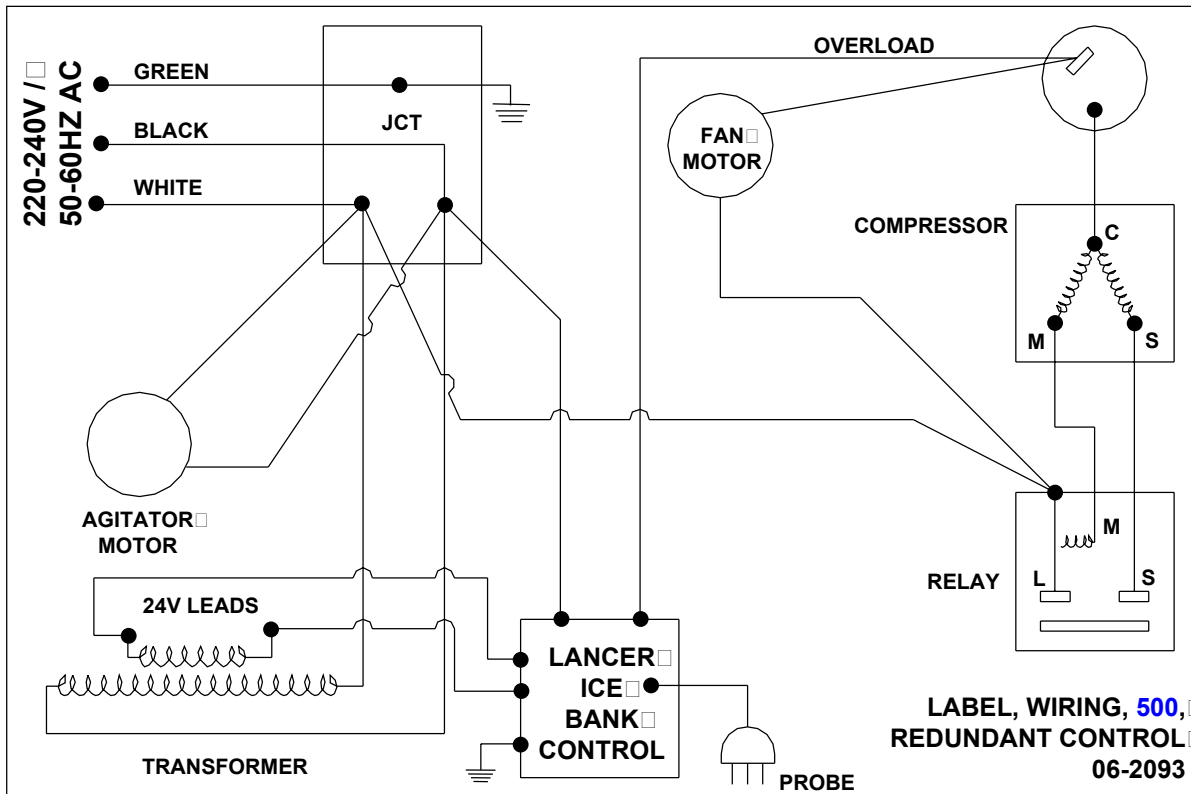

06-2093 USED ON PN 82-2665 (230V/50HZ) AND PN 82-2666 (240V/60HZ)

5.2 **500 CED WIRING DIAGRAM, 115V/60HZ, LANCER ELECTRONIC ICE BANK CONTROL AND CONTROL HOUSING CONNECTIONS, USA ONLY**

IMPORTANT

WHEN STARTING UNIT OR IF CURRENT IS INTERRUPTED, THERE IS A FIVE (5) MINUTE DELAY BEFORE THE COMPRESSOR/FAN STARTS.

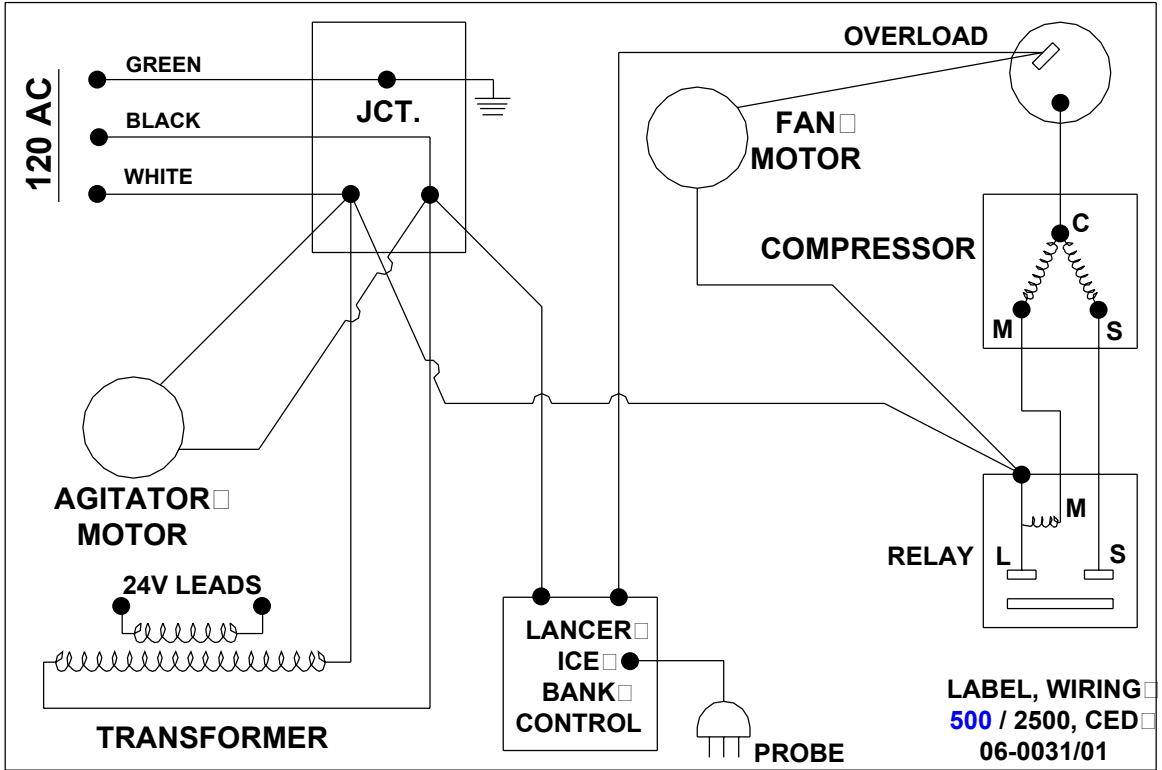

LABEL, WIRING DIAGRAM, CED, PN 06-0031/01

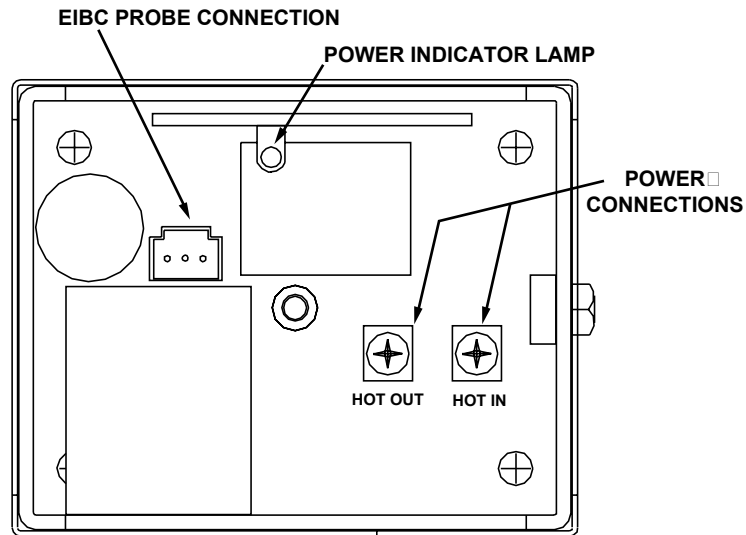

CONTROL HOUSING CONNECTIONS

5.3 CABINET ASSEMBLY

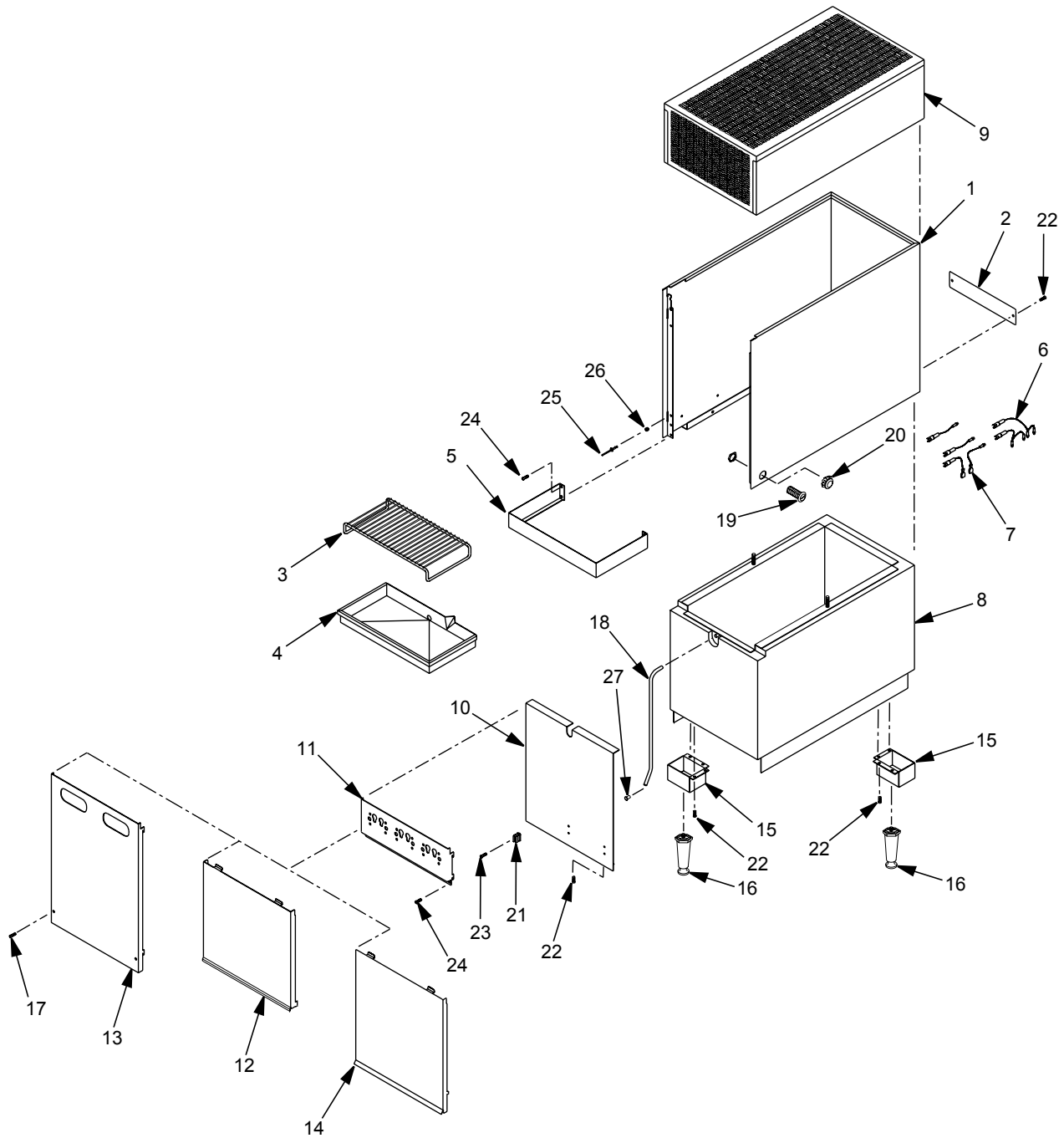

5.3 CABINET ASSEMBLY (CONTINUED)

<u>ITEM</u>	<u>PART NO.</u>	<u>Description</u>
1	30-5260/01	Wrapper, Cabinet
2	07-0347	Plate, Cover
3	23-1111	Cup Rest
4	51-0735	Drip Tray Assy
5	30-5037	Frame, Drip Tray
6	52-0843	Wire Harness, 2 Valve
-	52-2103	Wire Harness, 3 Valve
-	52-0842	Wire Harness, 4 Valve
7	52-0849/01	Wire Harness, Key Lock (Optional)
8	42-0017	Tank Assy, Insulated
9	23-0687	Bonnet Assy, White
10	30-5038	Front Support Plate
11	30-5257	Faucet Plate, 2 Valve
-	30-7212	Faucet Plate, 3 Valve
-	30-5255/01	Faucet Plate, 4 Valve
12	30-6746	Splash Plate
13	30-5469	Front Plate, Chiller
14	30-6612	Splash Plate, Extended (No Drip Tray)
15	51-0494/01	Support, Leg
16	81-0112	Leg, Adjustable
17	04-0529	Screw, 8 - 32 x 0.750
18	08-0100	Tubing
19	12-0097	Keylock Switch (Optional)
20	07-0405	Hole Plug (Optional)
21	03-0036	Clip
22	04-0061	Screw, 8 - 18 x 0.500
23	04-0077	Screw, 4 - 20 x 0.250
24	04-0477	Screw, 8 - 32 x 0.375
25	04-0429	Rivet
26	01-1824	Spacer
27	01-0450	Tube Support
-	REF	CAGE ASSY Part Numbers
-	23-0796/01	2 Valve, Cold, Split
-	23-0905	2 Valve, Hot, Split
-	23-1224/02	3 Valve, Cold, Flooded
-	23-1225/02	3 Valve, Cold, Split
-	23-0891/01	4 Valve, Cold, Split, 2 and 2
-	23-0892	4 Valve, Hot, Split, 2 and 2
-	23-0718-01	4 Valve, Hot, Flooded
-	23-0705-01/01	4 Valve, Cold, Flooded
-	23-0774	4 Valve, Pre-Mix
-	23-0903	1 Circuit, Chiller
-	23-0896	2 Circuit, Chiller
-	23-1125/01	3 Circuit, Chiller

5.4 COMPRESSOR DECK ASSEMBLY

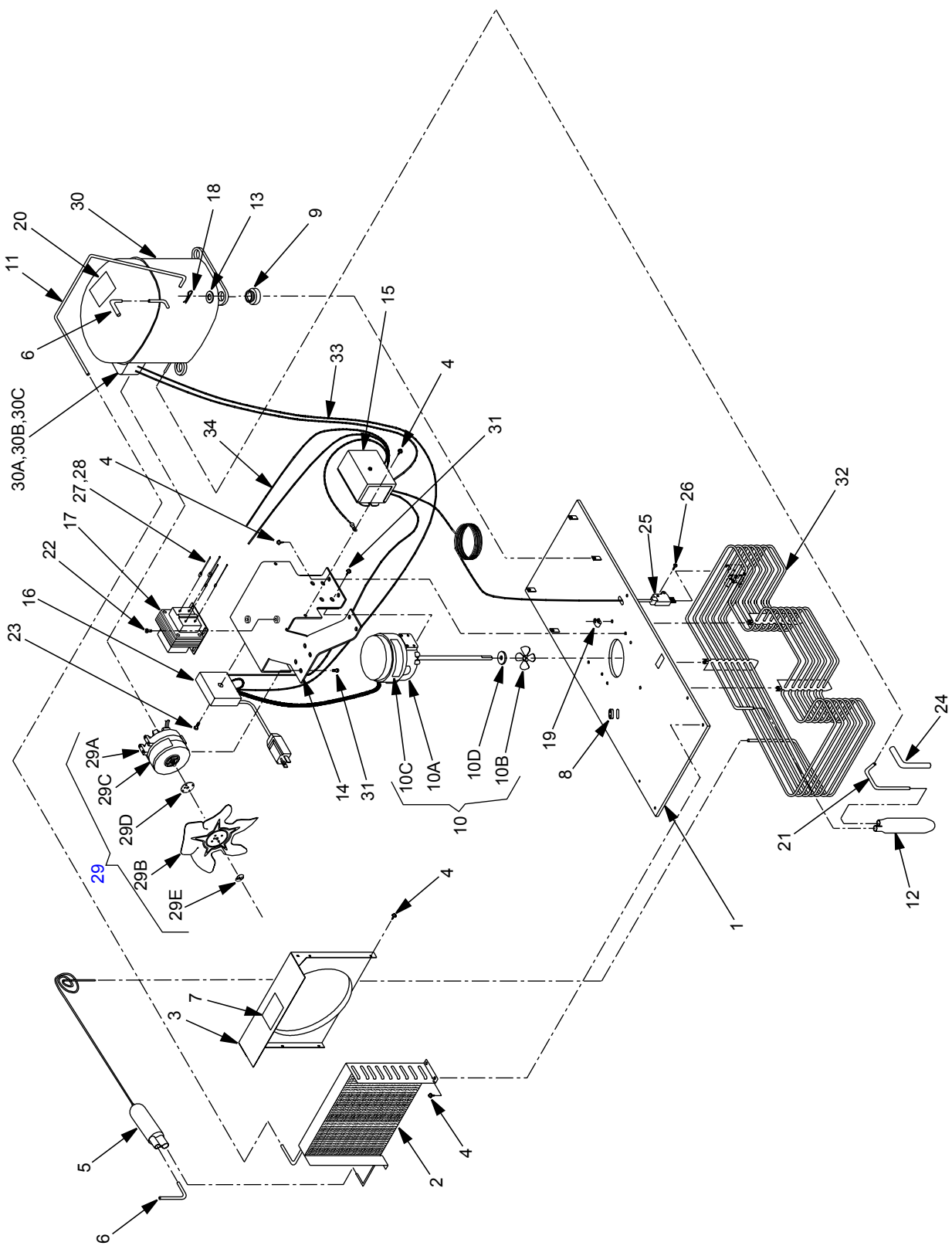

5.4 COMPRESSOR DECK ASSEMBLY (CONTINUED)

<u>ITEM</u>	<u>PART NO.</u>	<u>DESCRIPTION</u>	<u>ITEM</u>	<u>PART NO.</u>	<u>DESCRIPTION</u>
-	82-2662	Compressor Deck Assy, 115V/60Hz	30	83-0045	Compressor, 115V/60Hz, 1/4 HP
-	82-2665	Compressor Deck Assy, 230V/50Hz	-	83-0047	Compressor, 230V/50Hz, 1/4 HP
-	82-2666	Compressor Deck Assy, 240V/60Hz	-	83-0046	Compressor, 240V/60Hz, 1/4 HP
1	82-2096	Deck SubAssy, with Insulation			
2	23-0955	Condensor	30A	12-0026	Relay, 115V/60Hz
3	30-5884	Fan Shroud	-	12-0060	Relay, 230V/50Hz
4	04-0504	Screw, 8 - 18 X 0.375	-	12-0252	Relay, 240V/60Hz
5	23-0982	Dryer/Capillary Assy	30B	12-0150	Overload, 115V/60Hz
6	47-0344	Process Tube	-	12-0250	Overload, 230V/50Hz
7	06-0031/01	Wiring Diagram, 115V/60Hz Only	-	12-0251	Overload, 240V/60Hz
-	06-2093	Wiring Diagram, 220v/50-60Hz Only	30C	12-0261	Start Capacitor, 240V/60Hz ONLY
8	02-0040	Seal	-	- - - - -	Refrigerant, R134A ONLY, 115V/60Hz, 240V/60Hz - 5.5 Ounces; 230V/50Hz - 5.75 Ounces
9	02-0114	Compressor Grommet	31	04-0059	Screw, 8 - 36 X 0.375
10	52-0845	Agitator Motor Assy, 115V/60Hz	32	23-1148	Evaporator Coil Assy
-	52-0916	Agitator Motor Assy, 220V/50-60Hz	33	52-2004	Harness Assy, EIBC
10A	91-0021	Agitator Motor, 115V/60Hz	34	52-2151	Harness Assy, EIBC-Transformer, 220-240V/50-60Hz ONLY
-	91-0022	Agitator Motor, 220V/50-60Hz			
10B	05-0502	Propeller, 2.25 Inch			
10C	06-0552/01	Label, 115V/60Hz, 15W			
-	06-0661	Label, 220V/50-60Hz, 15W			
10D	02-0032	Washer, Rubber			
11	47-0607/01	High Side Tube			
12	51-0061	Accumulator			
13	04-0537	Washer, 0.467 ID X 0.923 OD			
14	51-0659/03	Fan Motor Bracket Assy			
15	52-1882	Electronic Ice Bank Control, 115V/60Hz ONLY			
-	52-2153	Electronic Ice Bank Control, 220V/50-60Hz ONLY			
16	52-0100	Power Junction Box Assy			
17	25-0039	Transformer, 115V/60Hz, 24V, 50VA			
-	25-0047	Transformer, 115V/60H, 24V, 75VA			
-	25-0048	Transformer, 220V/50-60Hz, 24V, 75VA			
18	03-0150	Retainer Clip, Compressor			
19	03-0028	Retainer Clip, Evaporator Coil			
20	06-0431	Label, 115V/60Hz, 1/4 HP			
-	06-0461	Label, 230V/50Hz, 1/4 HP			
-	06-0744	Label, 240V/60Hz, 1/4 HP			
21	47-0746/02	Low Side Tube			
22	04-0237	Screw, 8-32 X .250			
23	04-0070	Screw, 10-24 X 1.312			
24	50-0268	Insulation Tube			
25	52-1897	EIBC Probe Assy, 115V/60Hz ONLY			
-	52-2053	EIBC Probe Assy, 220V/50-60Hz ONLY			
26	04-0394	Screw, 6 - 32 X 0.500, SS			
27	52-0878	Lead Assy, Primary, BLK/WHITE			
28	52-0879	Lead Assy, Primary, BLK			
29	52-1258	Fan Motor Assy, 115V/60Hz, 9W			
-	52-0915	Fan Motor Assy, 220V/50-60Hz, 5W			
29A	91-0007	Fan Motor, 115V/60Hz, 9W			
-	91-0035	Fan Motor, 220V/50-60Hz, 5W			
29B	07-0389	Fan Blade			
29C	06-0433/01	Label, 115V/60Hz, 9W			
-	06-0725	Label, 230V/50-60Hz, 5W			
29D	02-0413	Fan Blade Silencer			
29E	04-0060	Fan Blade Nut			

NOTES

(Continued from previous page)

EcuLancer S.A. - Ecuador

Lancer Sales Company
Contact: Luciano Lopez
Sector Las Acacias
Luis De Beethoven #958
Y Capitan Rafael Ramos
Quito, Ecuador
Phone: 593-22-401-598, 400-937, 406-418
FAX: 593-22-400-535
e-mail: Llopez@ecnet.ec

Lancer Authorized Distributors**Eximport & Barter Co. - Caribbean**

2101 S.W. 56th Terrace
Hollywood, FL 33023 USA
Phone: (954) 967-9999
FAX: (954) 967-9900
e-mail: edbrandao@aol.com

PromoVen, S.A. - Argentina

Contact: Rafael Mendoza
Juncal 858 - Piso 3 Depto. "L"
(1062) Buenos Aires
Argentina
Phone: (54.11)4394.7654
FAX: (54.11)4394.1193
e-mail: promoven@customw.com.ar

Bras Sulamericana LTDA. - Brasil

Contact: Fabio Queiroz
Rua. Dr. Ladislau Retti, 1400
Parque Alexandre
Cotia Sao Paulo - Brasil
CEP: 06714-150
Phone: 55-11-4612-1122
FAX: 55-11-4612-2219
e-mail: fabio.queiroz@bras.com.br

Lancer Chile Ltda. - Chile

Contact: Heriberto Concha
Vicuna Mackenna 3019, San Joaquin
Santiago, Chile
Phone: 56-2-552-1657
FAX: 56-2-552-1961
e-mail: hconcha@lancer-intl.com

Lancer Pacific**International Sales**

6655 Lancer Blvd.
San Antonio, TX 78219
Phone: (210) 310-7000
FAX: (210) 310-7242
1-800-729-1500
e-mail: asia@lancercorp.com

Australia

Lancer Pacific Pty Ltd
5 Toogood Avenue
Beverley SA 5009
Australia
Phone: 61-8-8268-1388
FAX: 61-8-8268-1978
e-mail: ian-lunniss@lancer-pacific.com.au
steve-sotiriou@lancer-pacific.com.au

Lancer Pacific Pty Ltd
7 Slough Avenue
Silverwater, NSW, 2128
Sydney, Australia
Phone: 61-2-9648-6840
FAX: 61-2-9648-6850
e-mail: richard-abraham@lancer-pacific.com.au
fiore-alvaro@lancer-pacific.com.au
(for Beer)
rob-burdock@lancer-pacific.com.au
(Senior Director - Asia)

Lancer Pacific Pty Ltd
55 Keele Street
Collingwood
Melbourne Victoria 3066
Australia
Phone: 03 8415 1920
FAX: 03 8415 1929
e-mail: glenn-blakiston@lancer-pacific.com.au

Lancer Pacific Pty Ltd
Unit 31, 284 Musgrave Drive
Coopers Plains 4108
Queensland
Australia
Phone: 61-7-3274-5700
FAX: 61-7-3875-1805
e-mail: brett-thomson@lancer-pacific.com.au

New Zealand

Lancer Pacific Ltd
9 O'Rourke Street
Onehunga, Auckland
New Zealand
Phone: 64-9-634-3612
FAX: 64-9-634-1472
e-mail: phil-mason@lancer-pacific.com.au

Hong Kong

Patrick Co - Area Manager - Asia
Phone: 852-29670900
FAX: 852-30105882
e-mail: patrickco@lancer-asia.com

Lancer Authorized Distributors**Shanghai Freser International Co Ltd. - China**

1856, Hu Tai Road
Shanghai, 200436, China
Phone: 86-21-5650-3555
FAX: 86-21-5650-2666
e-mail: daniel@freser.com.cn

Freser (HK) Company Ltd - Hong Kong

Flat A, 24/F., Houston Industrial Bldg.
32-40 Wang Lung Street
Tsuen Wan, N. T., Hong Kong
Phone: 852-2408-2595
FAX: 852-2408-2605
e-mail: freserhk@netvigator.com

P.T. Ciptaratama Sentosamakmur - Indonesia

Jl. Anggrek Nelly Murni, Blok A - 39, Slipi
Jakarta 11480, Indonesia
Phone: 62-21-532-3737
FAX: 62-21-532-3666
e-mail: ciptasm@indosat.net.id

Hayakawa Sanki - Japan

Hayakawa Sanki, Inc.
1-13-13, Kayaba-cho
Nihonbashi, Chuo-ku
Tokyo, 103-0025
Japan
Phone: 03-5651-1481
FAX: 03-5651-1445
e-mail: SANKI10217@aol.com

Tahoe Corporation - Korea

Tahoe Corporation
2FL, 835-66 Yocksam-dong
Kangnam-Ku
Seoul, Korea
Phone: 82-2-557-5612, -5614
FAX: 82-2-557-5615
e-mail: tahoe@netgo.com

Freser (MALAYSIA) SDN. BHD. - Malaysia

No. 31, Jalan TPP 5/13, Taman
Perindustrian Puchong, Seksyen 5,
47100 Puchong, Selangor, Malaysia
Phone: 60-3-8061-6666
FAX: 60-3-8062-1007
e-mail: freser@tm.net.my

R.B.P. Industrial Sales Inc - Philippines

Unit 20, Facilities Centre Bldg.
548 Shaw Blvd
Mandaluyong City, Philippines
Phone: 632-531-1215/1221/1289
FAX: 632-531-1271
e-mail: rbpsales@info.com.ph

Freser (S) Pte Ltd - Singapore

Blk 998 Toa Payoh North
#04-12/14
Singapore 318993
Phone: 65-6352-0943
FAX: 65-6352-8594
e-mail: fresersin@pacific.net.sg

Freser International Corporation - Taiwan

No. 76, Gui-Sui Street
Taipei 103, Taiwan R.O.C.
Phone: 886-2-2553-1555
FAX: 886-2-2553-2742
e-mail: allen@intl.freser.com.tw

Freser (Thailand) Co Ltd - Thailand

3/15 Moo 3, Soi Ruammitr
Tivanont Road, Banmai
Pakkred, Nonthaburi, 11120
Thailand
Phone: 662-961-9543
FAX: 662-961-9550
e-mail: prachat@asianet.co.th

Lancer - Indian Sub-Continent**India**

Shabbir Shafiqui - Area Manager
India and Sub-Continent
B-7, Pannalal Silk Mill Compounds
78, LBS Marg, Bhandup (W)
Mumbai 400-078, India
Phone: 91-22-2561-6665
Cel No.: 91-98-2029-5252
FAX: 91-22-5637-4018
e-mail: shafiquis@vsnl.com

Lancer Authorized Distributors**Western Refrigeration Ltd - India**

B-7, Pannalal Silk Mill Compounds
78 L.B.S. Marg, Bhandup (W)
Mumbai 400-078, India
Phone: 91-22-2561-6665
FAX: 91-22-2562-2257
e-mail: western@bom5.vsnl.net.in

Bengal Marketing Company - Bangladesh

Skylark Point (6th Floor)
Room #G-2
24/A Bijoy Nagar,
Dhaka-1000, Bangladesh
Phone: 880-2-934-2987
FAX: 880-2-935-0127
e-mail: bmc@dhaka.agni.com

Dynamic Equipment - Pakistan

Dynamic Equipment and Controls (Pvt.) Ltd.
F-1/23, Canal Cottages, Block-D.
New Muslim Town.
Lahore, Pakistan.
Phone: 0092-42-583-6737
0092-42-583-6787
FAX: 0092-42-586-7924
e-mail: info@dynamic-eqpt.com.pk



**Directory of USA - Canada Offices,
International Offices, and Authorized Distributors**

Corporate Office

6655 Lancer Blvd. • San Antonio, Texas 78219 • 210-310-7000 • 1-800-729-1500 • FAX 210-310-7250

Lancer USA

Manufacturing Locations

Foster Road Facilities

6655 Lancer Blvd
San Antonio, TX 78219
Phone: (210) 310-7000
MFG FAX: (210) 310-7088
ENG FAX: (210) 310-7096
ACCT FAX: (210) 310-7091
PURCH FAX: (210) 310-7094

Lancer FBD

5620 Business Park
San Antonio, TX 78218
Phone: (210) 666-0544
FAX: (210) 666-2044

Lancer Ice Link

6655 Lancer Blvd
San Antonio, TX 78219
Phone: (210) 310-7174
FAX: (210) 310-7245

Remanufacturing

6655 Lancer Blvd
San Antonio, TX 78219
Phone: (210) 310-7356
FAX: (210) 310-7261
1-800-729-1550

Lancer North America

USA - Canada Sales
6655 Lancer Blvd.
San Antonio, TX 78219
Phone: (210) 310-7000
SALES FAX: (210) 310-7245
CUSTOMER SERVICE FAX: (210) 310-7250
1-800-729-1500

Georgia Office

1125 Northmeadow Parkway, Suite 116
Roswell, GA 30076
Phone: (770) 343-8828
FAX: (770) 475-8646
1-800-729-1750

Lancer Authorized Distributors

Advanced Beverage Solutions (ABS)

1425 South Wright Blvd.
Schaumburg, IL 60193
Phone: (847) 524-1707
(877) 814-2271
FAX: (847) 524-1710
www.absone.com

Bevco

6900 Camille Avenue
Oklahoma City, OK 73149
Phone: (405) 672-7770
FAX: (405) 672-7443
e-mail: info@bevcoinc.com

Joe Kirwan Company

119 White Oak Lane
Old Bridge, NJ 08857
Phone: (732) 679-1900
FAX: (732) 679-9236
e-mail: sales@jkirwan.com

L & M Beverage Equipment Co. Inc.

12510 Santa Fe Trail Drive
Lenexa, KS 66215
Phone: (913) 888-8988
FAX: (913) 888-9137
e-mail: L7mco@aol.com

(Update #43 - as of March 05, 2003)

Ernest F. Mariani Company

614 West 600 South
Salt Lake City, UT 84104
Phone: (801) 359-3744
FAX: (801) 531-9615
e-mail: febell@efmco.com, or
clay@efmco.com

Mark Powers & Company, Inc.

P.O. Box 72
1821 Henry Street
Guntersville, AL 35976
Phone: (256) 582-6620
FAX: (256) 582-8533
e-mail: sales@markpowers-and-
company.com

Maurer Supply, Inc.

843 Rainier Avenue South
Seattle, WA 98144
Phone: (206) 323-8640
FAX: (206) 323-9286
e-mail: maurersupply@qwest.net

Simgo Ltd.

5122 Timberlea Blvd.
Mississauga, Ontario L4W 2S5
Canada
Phone: 905-602-5800
FAX: 905-602-5804
e-mail: simgo@simgo.com

Simgo (B.C.) Ltd.

16-8125 - 130th Street
Surrey, B.C. V3W 7X4
Canada
Phone: 604-590-4022
FAX: 604-590-1601

Lancer Europe

Belgium - European Central Office

Lancer Europe, S.A.
Mechelsesteenweg 592
B-1930 Zaventem
Belgium
Phone: 32-2-755-2390
FAX: 32-2-755-2399
e-mail: lancer.europe@glo.be

England

17 Bembridge Gardens
Ruislip, Middlesex
HA4 7ER, England
Phone: 44-1895672667
FAX: 44-1895637537
e-mail: court4lancer@msn.com

Hungary

H-2100 Gödöllő
Isaszegi út 67
Hungary
Phone: 36-28-417-179
FAX: 36-28416-881
e-mail: bodolai@compuserve.com

Lancer Authorized Distributors

**Complete Beverage Services, Ltd.
Republic of Ireland and Northern Ireland**

Gortrush Industrial Estate
Omagh County Tyrone
Northern Ireland
Office: 44-1662 250 008
FAX: 44-1662-252-991

Intercom - Spain

Intercom
Avda. Concha Espina 8
28036 Madrid Spain
Phone: 34-91-564 6900
FAX: 34-91-564 3065
e-mail: jmorales@bevsvr.com

Lancer Russia

Lancer Sales Company

Vyatskaya Street 27
Building 15, 4th Floor
125015 Moscow, Russia
Phone: 7-095-745-7108
FAX: 7-095-745-7109
Mobile Phone: 7-095-991-7778
7-095-139-0335

e-mail: lancer@online.ru
vdemkin@ktv.ru

Lancer Middle East / Africa

Elsayed Moniem - Technical Manager
Lancer Middle East/Africa
7 Mubarak Street
East Ain Shams 11311
Cairo, Egypt
Phone/FAX: 2-02-49-35-395
Mobile Phone (GSM): 2-010-500-4007
e-mail: elsayed_lancer@msn.com

Lancer Authorized Distributor

DispenseTech - South Africa

P.O. Box 17495
Sunward Park, 1470
South Africa
Phone: 27-11-397-7455
FAX: 27-11-397-7648
e-mail: david@dispensetech.co.za

Lancer Latin America

Latin America Sales
6655 Lancer Blvd.
San Antonio, TX 78219
Phone: (210) 310-7000
FAX: (210) 310-7245
1-800-729-1500
e-mail: latinamerica@lancercorp.com

Lancer de México, S.A. de C.V.

Contact: Gerardo Canales
Calle Lerdo De Tejada #544 PTE.
Col. Las Villas
San Nicolas De Los Garza, N.L.
Monterrey, N. L., México C.P. 66422
Phone: (52)-81-83-52-85-32
Phone: (52)-81-83-52-85-34
Phone: (52)-81-83-52-53-60
FAX: (52)-81-83-32-54-10
e-mail: direccion@lancer.com.mx

Lancer de México, S.A. de C.V.

Branch Office, Mexico City

Contact: Carlos Lopez
Lancer de Mexico S.A. de C.V.
Sucursal Mexico D.F.
Calle: Centeotl No. 112
Colonia: La Preciosa
Delegacion: Azcapotzalco
Mexico D.F. C.P. 02460
Phone: (52)-55-53-53-89-28
Phone: (52)-55-53-53-89-26
Phone: (52)-55-53-53-88-60
Phone: (52)-55-53-53-88-21
FAX: (52)-55-53-52-46-30
e-mail: lancer@prodigy.net.mx

Lancer de México, Branch Office, Cd.

Juarez

Contact: Yolanda Puga
Lancer de Mexico
Camino de la Lomas # 4380
Col. Partido Iglesias
Cd. Juarez, CHIH, C.P. 32617
México
Phone and FAX: 521-605-00-86
Phone: 521-605-00-87
e-mail: cdjuarez@lancer.com.mx

(Continued on reverse)