

LANCER

Please refer to the Lancer web site (www.lancercorp.com) for information relating to Lancer Installation and Service Manuals, Instruction Sheets, Technical Bulletins, Service Bulletins, etc.

**INSTALLATION AND SERVICE
MANUAL
FOR
LANCER SERIES 2500
DISPENSERS**

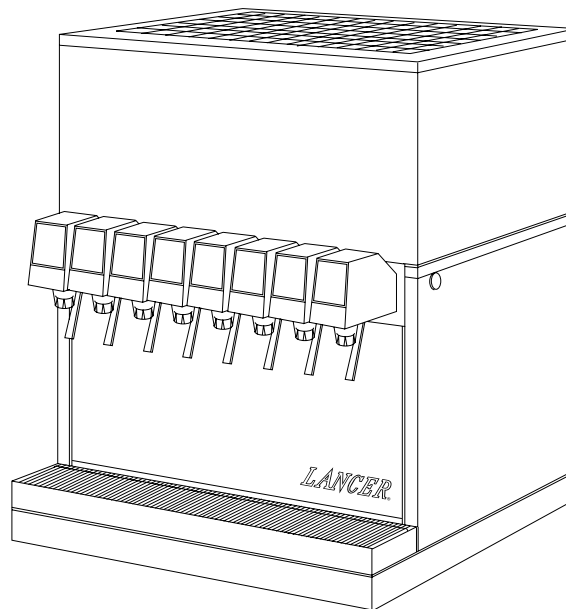

This Manual supersedes Installation and Service Manual, 28-0089/03, dated 01/15/99, and is being published ONLY on the Lancer Web Site

LANCER

6655 LANCER BLVD. • SAN ANTONIO, TEXAS 78219 USA • (210) 310-7000

FAX SALES

• NORTH AMERICA – 210-310-7245 • INTERNATIONAL SALES – 210-310-7242 • CUSTOMER SERVICE – 210-310-7242 •
• LATIN AMERICA – 210-310-7245 • EUROPE – 32-2-755-2399 • PACIFIC – 61-8-8268-1978 •

FAX ENGINEERING: • 210-310-7096

"Lancer" is the registered trademark of Lancer • Copyright — 2004 by Lancer, all rights reserved.

REV: 10/06/04
P.N. 28-0089/04

TABLE OF CONTENTS

TABLE OF CONTENTS	i
SPECIFICATIONS	ii
1 INSTALLATION	1
1.1 RECEIVING.....	1
1.2 UNPACKING	1
1.3 SELECTING A COUNTER LOCATION.....	1
1.4 CONNECTING THE DRAIN.....	1
1.5 FILLING UNIT WITH WATER	1
1.6 CONNECTING TO ELECTRICAL POWER	2
1.7 CONNECTING TO PLAIN WATER SUPPLY	2
1.8 CONNECTING TO CARBONATED WATER SUPPLY.....	3
1.9 CONNECTING TO SYRUP SUPPLY.....	3
1.10 ADJUSTING WATER FLOW.....	3
1.11 ADJUSTING WATER TO SYRUP (RATIO) BRIX	3
2. SCHEDULED MAINTENANCE	4
2.1 DAILY	4
2.2 WEEKLY.....	4
2.3 MONTHLY	4
2.4 EVERY SIX MONTHS.....	4
2.5 YEARLY.....	4
3. DISPENSER CLEANING AND SANITIZING	4
3.1 AMBIENT PROCESS.....	4
3.2 VALVES.....	4
4. TROUBLESHOOTING	5
4.1 WATER LEAKAGE AROUND NOZZLE	5
4.2 LEAKAGE BETWEEN UPPER AND LOWER VALVE BODIES.....	5
4.3 MISCELLANEOUS LEAKAGE	5
4.4 INSUFFICIENT WATER FLOW.....	5
4.5 INSUFFICIENT SYRUP FLOW.....	5
4.6 ERRATIC RATIO	5
4.7 NO PRODUCT DISPENSED	5
4.8 WATER ONLY DISPENSED; NO SYRUP; OR SYRUP ONLY DISPENSED, NO WATER.....	6
4.9 VALVE WILL NOT SHUT OFF	6
4.10 EXCESSIVE FOAMING	6
4.11 COMPRESSOR DOES NOT START (NO HUM), BUT CONDENSER FAN MOTOR RUNS.....	6
4.12 COMPRESSOR STARTS AND CONTINUES TO RUN UNTIL FREEZE UP AND WILL NOT CUT OFF	6
4.13 COMPRESSOR DOES NOT START BUT HUMS	6
4.14 COMPRESSOR STARTS BUT DOES NOT SWITCH OFF START WINDING (WILL RUN FOR ONLY A FEW SECONDS BEFORE INTERNAL OVERLOAD SWITCHES COMPRESSOR OFF).....	6
4.15 COMPRESSOR STARTS AND RUNS A SHORT TIME BUT SHUTS OFF ON OVERLOAD	6
4.16 COMPRESSOR AND CONDENSER FAN MOTOR WILL NOT START AFTER FIVE (5) MINUTE POWER OFF DELAY (LANCER EIBC, EXPORT ONLY).....	7
4.17 COMPRESSOR AND CONDENSER FAN MOTOR WILL NOT START AFTER FIVE (5) MINUTE POWER OFF DELAY (LANCER EIBC, USA ONLY)	7
4.18 WARM DRINKS	7
5. ILLUSTRATIONS, PARTS LISTS, AND WIRING DIAGRAMS	8
5.1 2500 REFRIGERATION DECK ASSEMBLY, R-134A, LANCER ELECTRONIC ICE BANK CONTROL (EIBC), USA ONLY, PN 82-2660 (MANUFACTURED FROM 01/99).....	8-9
5.2 2500 REFRIGERATION DECK ASSEMBLY, WITH ELECTRONIC ICE BANK CONTROL (EIBC), R-134A; PN 82-2049E, 230V/50HZ; PN 82-2103E, 115V/60HZ; PN 82-2098E, 240V/60HZ.....	10-11
5.3 2500 CONTROL HOUSING ASSEMBLY, ELECTRONIC ICE BANK CONTROL (EIBC), INTERNATIONAL ONLY	12-13
5.4 2500 CABINET ASSEMBLY.....	14-15
5.5 2500 WIRING DIAGRAM AND HOUSING CONNECTIONS, LANCER ELECTRONIC ICE BANK CONTROL USA ONLY	16
5.6 2500 WIRING DIAGRAM, ELECTRONIC ICE BANK CONTROL (EIBC) INTERNATIONAL ONLY	17
5.7 2500 INSTALLATION KITS AND OPTIONAL ACCESSORIES.....	18

SPECIFICATIONS

DIMENSIONS

Width	26 inches (660 mm)
Depth	27 1/8 inches (690 mm)
Height (without legs)	31 1/4 inches (790 mm)

WEIGHT

Shipping	257 pounds (117 kg)
Empty	209 pounds (95 kg)
Operating	376 pounds (171 kg)

ICE BANK WEIGHT

50 pounds (23 kg) Nominal

WATER BATH CAPACITY

21 gallons (79 Liters)

COMPRESSOR

3/4 HP Tecumseh, 115V/60Hz

AGITATOR MOTOR

25 WATT, 115V

CONDENSER MOTOR

35 WATT, 115V

ICE BANK CONTROL

Lancer Electronic Ice Bank Control (EIBC)

TRANSFORMER

Basler, 115V (Primary)/24V (Secondary)

OPTIONAL

230V/50Hz and 240V/60 Hz systems available

DRINK CAPACITY

538 - 12 ounce drinks under 40°F (4.4°C) at four (4) drinks per minute with 75°F (23.9°C) ambient inlet water and syrup.

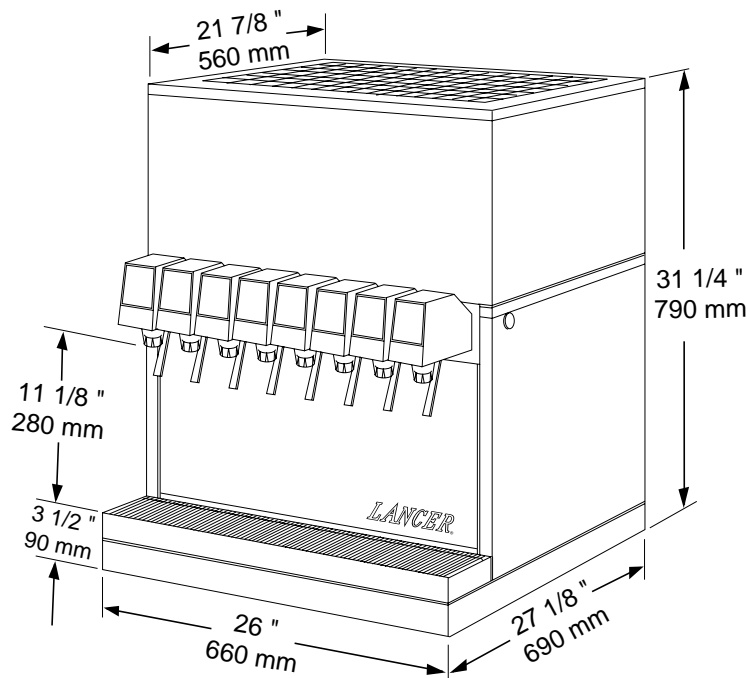

NOTES

NOTES

1. INSTALLATION

1.1 RECEIVING

Each unit is completely tested under operating conditions and thoroughly inspected before shipment. At time of shipment, the carrier accepts the unit and any claim for damages must be made with the carrier. Upon receiving units from the delivering carrier, carefully inspect carton for visible indication of damage. If damage exists, have carrier note same on bill of lading and file a claim with the carrier.

1.2 UNPACKING

- A. Cut band and remove.
- B. Remove top portion of carton by lifting up.
- C. Remove top inner carton pad and corners.
- D. Lift Unit up by plywood shipping base and remove lower portion of carton.
- E. Inspect unit for concealed damage and if evident, notify delivering carrier and file a claim against same.
- F. Remove plywood shipping base from unit by moving unit so that one side is off the counter top or table, allowing access to screws on the bottom of the plywood shipping base.

NOTE

If unit is to be transported, it is advisable to leave unit secured to plywood shipping base.

- G. If Unit is to be installed with optional legs, assemble legs to unit by tilting unit. **DO NOT LAY UNIT ON ITS SIDE OR BACK.**
- H. Remove accessory kit of loose parts from drip tray.

1.3 SELECTING A COUNTER LOCATION

The dispenser is designed to sit on a flat, supported surface capable of supporting a minimum weight of 400 pounds (182 kg). It may be either counter or leg mounted. A template is furnished to cut and/or drill the necessary holes for mounting. When the dispenser is to be permanently bolted to the counter top, seal dispenser base to counter top with a silicone sealant which provides a smooth and easily cleanable bond to the counter.

NOTE

NSF listed units must be sealed to the counter or have four (4) inch legs installed.

WARNING

FAILURE TO MAINTAIN THE PROPER AIR CLEARANCE WILL CAUSE THE COMPRESSOR TO OVERHEAT AND WILL RESULT IN PREMATURE COMPRESSOR FAILURE.

Locate dispenser to allow approximately 15 inches (380 mm) of unobstructed space above and six (6) inches (160 mm) behind the unit for proper air circulation. Air is drawn in through the back grill and exhausted out of the top grill.

1.4 CONNECTING THE DRAIN

- A. Remove cup rest. Lift splash plate up and pull out and down on the bottom to remove.
- B. Remove the drip tray from the unit and connect the drain tube to the drain fitting located on the bottom. Secure drain tube with clamp provided in accessory kit.
- C. Route the drain tube to a suitable drain and replace the unit's drip tray.

1.5 FILLING UNIT WITH WATER

- A. Remove the bonnet from the unit.
- B. Remove the yellow plastic plug from the fill hole.
- C. Using a funnel or tube, fill the water bath compartment with water until it flows out of the overflow tube into the drip tray. Use bottled water where a water problem exists.
- D. Replace the yellow plug.

1.6 CONNECTING TO ELECTRICAL POWER

WARNING

THIS UNIT MUST BE PROPERLY ELECTRICALLY GROUNDED TO AVOID POSSIBLE FATAL ELECTRICAL SHOCK OR SERIOUS INJURY TO THE OPERATOR. THE POWER CORD IS PROVIDED WITH A THREE PRONG GROUNDED PLUG. IF A THREE-HOLE GROUNDED ELECTRICAL OUTLET IS NOT AVAILABLE, USE AN APPROVED METHOD TO GROUND THE UNIT.

DO NOT USE EXTENSION CORDS WITH THIS UNIT. DO NOT "GANG" TOGETHER WITH OTHER ELECTRICAL DEVICES ON THE SAME OUTLET.

- Check the dispenser serial number plate for unit's correct electrical requirements. Do not plug into electrical outlet unless unit electrical configuration, located on serial plate, agrees with local available power supply.
- Route the power supply cord to a grounded electrical outlet of the proper voltage and amperage rating, and plug in the unit. This will turn on the refrigeration system and allow it to start cooling while completing the rest of the installation. Approximately three (3) hours are required to form a full ice bank.

NOTE

Units equipped with an electronic ice bank control contain a five (5) minute delay. Compressor and fan motor will not begin running until five (5) minutes after the unit is energized.

1.7 CONNECTING TO PLAIN WATER SUPPLY

See Figure 1.

If unit has no plain water circuits, proceed to Section 1.8.

- Valves 4, 5, and 6 through 8 (on 8 valve units) and valves 3, 4, and 5 (on 6 valve units) have optional plain water or carbonated water capabilities. Using Figure 1, determine which valves are to be plumbed with plain water.
- Using proper beverage tubing and fittings, connect to water source [must be 35 PSI (2.4 bar) or more].
- Flush water supply line thoroughly.
- Route tubing through cutout in counter or through access hole in back of unit.
- Leave 12 inches (300 mm) of extra tubing length below the counter for servicing and moving the dispenser.
- Connect to desired plain water inlet behind splash plate and secure with Oetiker Clamp.
- Turn on water supply and check for leaks.
- Actuate each valve until all air is expelled.

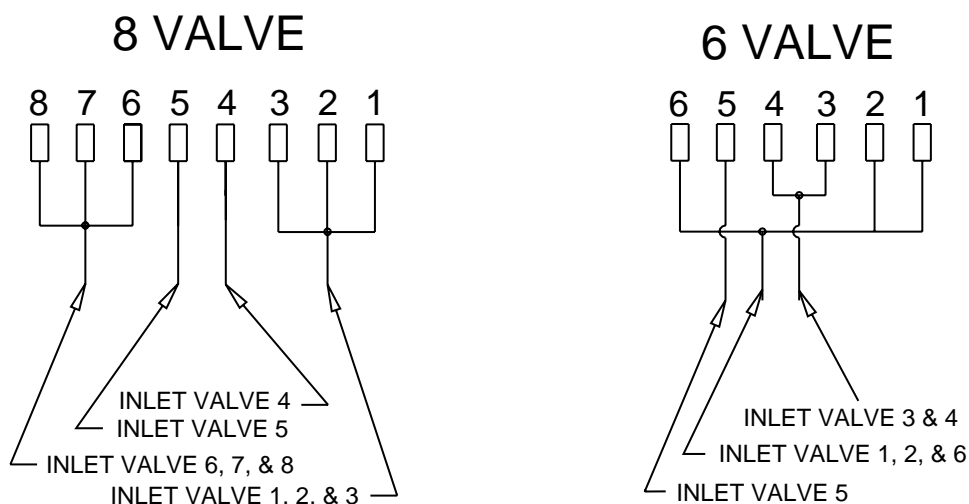

Plumbing Diagram, Carbonated/Plain Water
Figure 1

1.8 CONNECTING TO CARBONATED WATER SUPPLY

See *Figure 1*.

- A. Install carbonator per manufacturer's instructions.
- B. Using proper beverage tubing and fittings, connect to carbonator tank outlets.
- C. Route tubing through cutout in counter or through access hole in back of unit.
- D. Leave 12 inches (300 mm) of extra tubing length below the counter for servicing and moving the dispenser.
- E. Connect to soda inlets behind splash plate and secure with Oetiker Clamps.
- F. Fill with water and pressurize carbonation system per manufacturer's instructions.
- G. Actuate each valve until a smooth flow of carbonated water is obtained.
- H. Check for leaks.

1.9 CONNECTING TO SYRUP SUPPLY

- A. Using proper beverage tubing and fittings, connect to syrup inlets and secure with Oetiker Clamps.
- B. Mark syrup tube assemblies with product ID tape.
- C. Route tubing through cutout in counter or through access hole in back of unit.
- D. Leave 12 inches (300 mm) of extra tubing length below the counter for servicing and moving the dispenser.
- E. Connect to appropriate five (5) gallon syrup containers or bag-in-box system.
- F. Pressurize system.
- G. Actuate each valve until product is observed.
- H. Check for leaks.

1.10 ADJUSTING WATER FLOW

- A. The water flow can be adjusted to either 1.25 oz/sec (37 ml/sec) or 2.50 oz/sec (74 ml/sec) on all dispensing valves using the following procedure.
- B. The refrigeration unit should have been running for at least one hour before you attempt to brix the valves. The drink temperature should be no higher than 40°F (4.4°C) when the brix is set. This is best done after the unit has made an ice bank.
- C. Slide up ID panel until flow controls are exposed.
- D. Remove nozzle by twisting counter clockwise and pulling down.
- E. Remove diffuser by pulling down.
- F. Install Lancer (yellow) syrup separator (PN 54-0031) in place of nozzle.
- G. Activate dispensing valve to fill separator syrup tube.
- H. Hold a Lancer brix cup under the syrup separator and dispense water and syrup into cup for four (4) seconds. Divide number of ounces (ml) of water in cup by four (4) to determine water flow rate per second.
- I. To obtain the proper flow, use a screwdriver to adjust water flow control (see Figure 2).
- J. Repeat process for each valve.

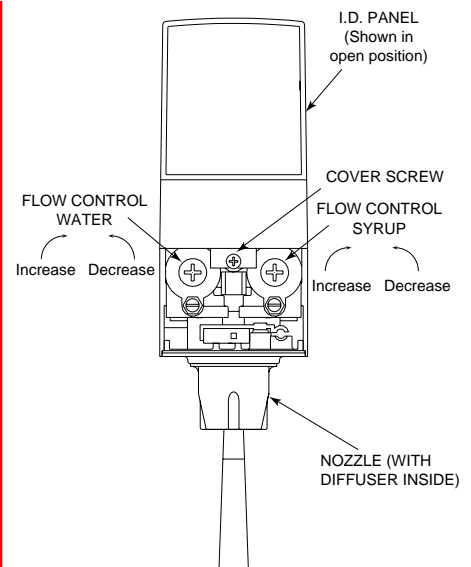

**Typical Valve Adjustment
Figure 2**

1.11 ADJUSTING WATER TO SYRUP (RATIO) BRX

- A. Hold the Lancer brix cup under the syrup separator and activate valve. Check brix.
- B. To obtain the proper brix, use screwdriver to adjust syrup flow control (see Figure 2).
- C. Remove the syrup separator.
- D. Install diffuser and nozzle.
- E. Slide down ID panel.
- F. Repeat process for each valve.

2. SCHEDULED MAINTENANCE

2.1 DAILY

- A. Remove the nozzle and diffuser from each valve and rinse well in warm water. *Do NOT use soap or detergent. This will cause foaming and off taste in finished product.*
- B. Remove the cup rest and wash in warm soapy water.
- C. Pour warm soapy water into the drip tray and wipe with a clean cloth.
- D. With a clean cloth and warm water, wipe off all of the unit's exterior surfaces. **DO NOT USE ABRASIVE SOAPS OR STRONG DETERGENTS.**
- E. Replace the cup rest, valve diffusers, and valve nozzles.

2.2 WEEKLY

- A. Taste each product for off tastes and/or brix changes.
- B. Remove the bonnet and check the level of water in the water bath. Replenish as required, and replace the bonnet.

2.3 MONTHLY

- A. Unplug the dispenser from power source.
- B. Remove the bonnet and clean the dirt from the condenser using a soft brush.
- C. Replace the bonnet and plug in the unit.

2.4 EVERY SIX MONTHS

- A. Clean and sanitize the unit using the appropriate procedures outlined in Section 3 of this manual.

2.5 YEARLY

- A. Clean water bath interior, including evaporator coils and refrigeration components.
- B. Clean the entire exterior of the unit.
- C. Sanitize syrup lines.

3. DISPENSER CLEANING AND SANITIZING

3.1 AMBIENT PROCESS

- A. The ambient process is the most common method for cleaning and sanitizing dispenser equipment. The detergent should be caustic-based and the sanitizer should be low pH (7.0) chloride solution.
- B. Disconnect syrup containers and remove product from tubing by purging with carbon dioxide.
- C. Rinse the lines and fittings with clean, room temperature water to remove all traces of residual product.
- D. Fill lines with a caustic-based (low-sudsing, non-perfumed, and easily rinsed) detergent solution. The solution should be prepared in accordance with the manufacturer's recommendations, but should be at least two (2) percent sodium hydroxide. Make sure the lines are completely filled and allow to stand for at least ten (10) minutes.
- E. Flush the detergent solution from the lines with clean water. Continue rinsing until testing with phenolphthalein shows that the rinse water is free of residual detergent.
- F. Fill the lines with a low pH (7.0) chlorine solution containing at least 50 parts per million (PPM) (50 mg/L) available chlorine. Make sure that lines are completely filled and allow to stand for ten (10) minutes.
- G. Reconnect syrup containers and ready Unit for operation.
- H. Draw drinks to refill lines and flush the chlorine solution from the dispenser.
- I. Taste the beverage to verify that there is no off taste.

3.2 VALVES

- A. Valves may be cleaned and sanitized in the same manner
 - 1. Remove cover and disconnect power so not to activate the valve while cleaning. Remove nozzle and diffuser. Wash these parts in cleaning solution, then immerse them in a bath of sanitizing solution for 15 minutes.

2. Visually inspect around nozzle area for syrup residue. This area may be cleaned with warm water and cloth or with the nozzle brush supplied. Wipe off dispensing lever.
3. Wearing sanitary gloves, remove, drain and air dry the nozzle and diffuser.
4. Wearing sanitary gloves, replace diffuser and twist nozzle into place.
5. Connect power and replace cover. Valve is ready for operation.

4. TROUBLESHOOTING

TROUBLE	CAUSE	REMEDY
4.1 Water leakage around nozzle.	A. Damaged or improperly installed o-ring above diffuser.	A. If damaged, replace. If improperly installed, adjust.
4.2 Leakage between upper and lower valve bodies.	A. Gap between upper and lower valve bodies. B. Worn or damaged paddle arm assemblies.	A. Tighten all six (6) retaining screws. B. Replace paddle arm assemblies.
4.3 Miscellaneous leakage.	A. Gap between parts. B. Damaged or improperly installed o-rings.	A. Tighten appropriate retaining screws. B. Replace or adjust appropriate o-rings.
4.4 Insufficient water flow.	A. Insufficient incoming supply water pressure. B. Shutoff on mounting block not fully open. C. Foreign debris in water flow control.	A. Verify incoming supply water pressure is a minimum of 35 PSI (2.4 bar). B. Open shutoff fully. C. Remove water flow control from upper body and clean out any foreign material to ensure smooth free spool movement.
4.5 Insufficient syrup flow.	A. Insufficient CO ₂ pressure to BIB Pumps. B. Shutoff on mounting block not fully open. C. Foreign debris in syrup flow control.	A. Adjust CO ₂ pressure to 80 PSI (5.5 bar) [minimum 70 PSI (4.8 bar)] for BIB pumps. B. Open shutoff fully. C. Remove syrup flow control from upper body and clean out any foreign material to ensure smooth free spool movement.
4.6 Erratic ratio.	A. Incoming water and/or syrup supply not at minimum flowing pressure. B. Foreign debris in water and/or syrup flow controls.	A. Check pressure and adjust. B. Remove flow controls from upper body and clean out any foreign material to ensure smooth free spool movement.
4.7 No product dispensed.	A. Water and syrup shutoffs on mounting block not fully open. B. The key switch on an electric valve is in the OFF position. C. Cup lever arm or ID panel actuator on electric valve is not actuating the switch. D. Electric current not reaching Valve. E. Improper or inadequate water or syrup supply. F. Tripped Circuit Breaker on 24 volt transformer.	A. Open shutoffs fully. B. Turn key switch to ON position. C. Repair. D. Check electric current supplied to valve. If current is adequate, check solenoid coil and switch, and replace if necessary. E. Remove valve from mounting block and open shutoffs slightly and check water and syrup flow. If no flow, check dispenser for freeze-up or other problems. F. Find cause of short and correct. Then reset transformer.

TROUBLE	CAUSE	REMEDY
4.8 Water only dispensed; no syrup; or syrup only dispensed, no water.	A. Water or syrup shutoff on mounting block not fully open. B. Improper or inadequate water or syrup flow. C. Kinked line.	A. Open shutoff fully. B. Remove valve from mounting block, open shutoffs slightly and check water and syrup flow. If no flow, check dispenser for freeze-up or other problems. Ensure BIB connection is engaged. C. Remove kink or replace line.
4.9 Valve will not shut off.	A. Cup lever may be sticking or binding. B. Switch not actuating freely. C. Solenoid armature not returning to bottom position.	A. Correct or replace lever. B. Check switch for free actuation. C. Replace defective armature or spring.
4.10 Excessive foaming.	A. Incoming water or syrup temperature too high. B. Water flow rate too high. C. Nozzle and diffuser not properly installed. D. Nozzle and diffuser not clean. E. Air in BIB lines. F. Poor quality ice. G. High beverage temperature.	A. Correct prior to dispenser. Consider larger dispenser or pre-cooler. B. Readjust and reset ratio. Refer to Sections 1.10 and 1.11. C. Remove and reinstall properly. D. Remove and clean. E. Bleed air from BIB lines. F. Check quality of ice used in drink. G. Check refrigeration system.
4.11 Compressor does not start (no hum), but condenser fan motor runs.	A. Compressor relay or overload malfunctioning. B. Inadequate voltage. C. Incorrect wiring. D. Compressor malfunctioning.	A. Replace compressor relay or overload. B. Measure voltage across common and run terminal on compressor. Voltage must not drop below 90% of rated voltage. C. Refer to wiring diagram and correct. D. Replace compressor.
4.12 Compressor starts and continues to run until freeze up and will not cut off.	A. Ice bank control failure. B. Incorrect wiring. C. Probe shorted.	A. Replace ice bank control. B. Refer to wiring diagram and correct. C. Check spring for foreign material or damage.
4.13 Compressor does not start but hums.	A. Inadequate voltage. B. Incorrect wiring. C. Starting relay malfunctioning. D. Compressor malfunctioning.	A. Measure voltage across common and run terminal on compressor. Voltage must not drop below 90% of rated voltage. B. Refer to wiring diagram and correct. C. Replace starting relay. Be sure to use correct relay. Failure to use correct relay will cause compressor failure. D. Replace compressor.
4.14 Compressor starts but does not switch off start winding (will run for only a few seconds before internal overload switches compressor off).	A. Inadequate voltage. B. Incorrect wiring. C. Starting relay malfunctioning.	A. Measure voltage across common and run terminal on compressor. B. Refer to wiring diagram and correct. C. Replace starting relay. Be sure to use correct relay. Failure to use correct relay will cause compressor failure.
4.15 Compressor starts and runs a short time but shuts off on overload.	A. Dirty condenser. B. Insufficient or blocked air flow. C. Inadequate voltage.	A. Clean the condenser. B. Remove all obstructions and allow for minimum clearances of 8 inches (203 mm) over top. C. Measure voltage across common and run terminal on compressor. Voltage must not drop below 90% of rated voltage.

Section 4.15 continued on next page

TROUBLE	CAUSE	REMEDY
<i>Section 4.15 continued from previous page</i>		
	D. Incorrect wiring. E. Defective condenser fan motor. F. Refrigerant leak. G. Compressor malfunctioning.	D. Refer to wiring diagram and correct. E. Replace condenser fan motor. F. Repair and recharge. G. Replace compressor.
4.16 Compressor and Condenser Fan Motor will not start after five (5) minute Power Off delay (Lancer EIBC Export only).	A. Fuse blown on EIBC PCB. B. Relay will not turn on compressor. C. Transformer tripped. D. Probe unplugged.	A. Replace fuse on EIBC PCB. B. Failed relay. Replace Control Board. C. Reset transformer. D. Check probe connections at PCB.
4.17 Compressor and Condenser Fan Motor will not start after five (5) minute Power Off delay (Lancer EIBC, USA Only).	A. Improper Wiring. B. Probe unplugged. C. Damaged electronics.	A. Check Power Indicator Lamp; check wiring per Wiring Diagram. B. Check Probe connection at PCB. C. Replace Control.
4.18 Warm drinks.	A. Restricted airflow. B. Dispenser connected to hot water supply. C. Refrigeration system not running. D. Refrigerant leak. E. Condenser fan motor not working. F. Dirty condenser. G. Dispenser capacity exceeded.	A. Check clearances around sides, top, and inlet of unit. Remove objects blocking airflow through grill. B. Switch to cold water supply. C. Refer to Sections 4.11 - 4.16. D. Repair and recharge. E. Replace condenser fan motor. F. Clean condenser. G. Add pre-cooler.

NOTES

5. ILLUSTRATIONS, PARTS LISTS, AND WIRING DIAGRAMS

5.1 2500 REFRIGERATION DECK ASSEMBLY, R-134A, LANCER ELECTRONIC ICE BANK CONTROL (EIBC), USA ONLY, PN 82-2669 (MANUFACTURED FROM 01/99)

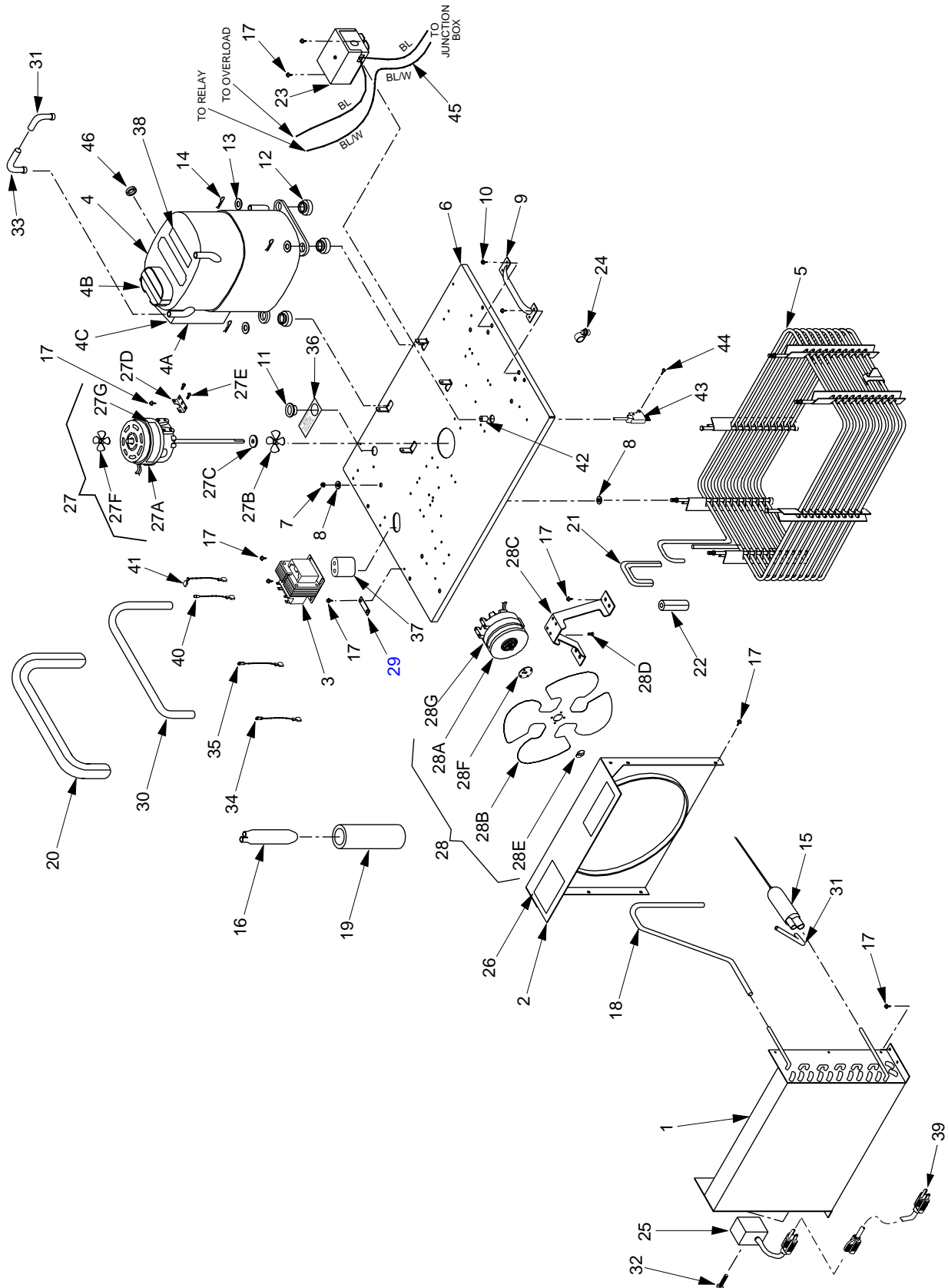

**5.1 2500 REFRIGERATION DECK ASSEMBLY, R-134A, LANCER ELECTRONIC ICE BANK CONTROL (EIBC), USA ONLY, PN 82-2669 (CONTINUED)
(MANUFACTURED FROM 01/99)**

ITEM	PART NO.	DESCRIPTION	ITEM	PART NO.	DESCRIPTION
1	23-0986	Condenser	36	06-0856/01	Fill Hole Label
2	51-0349	Shroud Assy	37	02-0040	Seal, Extrusion
3	25-0047	Transformer, 115V/60Hz	38	06-0663	Label, 115V/60Hz, 3/4 HP
4	83-0101	Compressor, 115V/60Hz	39	21-0085	Power Cord, USA
4A	12-0233	Start Capacitor, 115V/60Hz	40	52-1504	Wire Assy, Secondary, White
4B	12-0227	Overload, 115V/60 Hz	41	52-1505	Wire Assy, Secondary, Black
4C	12-0232	Relay, 115V/60Hz	42	02-0041	Seal
-	-----	Refrigerant, R134A Only, 15.5 Ounces	43	52-1897	Probe Assy
5	23-1205	Evaporator Coil Assy	44	04-0394	Screw, 6 - 32 x 0.500, PHP, SS
6	82-0675	Compressor Deck Assy	45	52-1827	Harness Assy, EIBC
7	04-0032	Nut, 1/4 - 20	46	13-0059	Bushing, Heyco
8	04-0063	Washer, 0.260 ID x 0.687 OD, SS			
9	07-0268	Deck Handle			
10	04-0260	Screw, 10 - 16 x 0.625			
11	04-0538	Fill Hole Plug			
12	02-0114	Grommet, Compressor			
13	04-0537	Washer, Compressor			
14	03-0150	Retainer Clip, Compressor			
15	23-0999	Dryer/Capillary Tube Assy			
16	51-5400	Accumulator			
17	04-0504	Screw, 8 - 18 x 0.375			
18	47-2064	Tube, High Side			
19	50-0105	Accumulator Insulator Boot			
20	50-0106	Insulation, Low Side			
21	50-0107	Insulation, Evaporator Outlet			
22	50-0108	Insulation, Evaporator Inlet			
23	52-1882	Electronic Ice Bank Control (EIBC)			
24	03-0049	Cord Clip			
25	52-0100	Power, Junction Assy			
26	06-0031/01	Wiring Diagram, 2500			
27	52-1259	Agitator Motor Assy, 115V/60Hz			
27A	91-0083	Motor, Agitator, 115V/60Hz			
27B	05-0502	Propeller, Agitator			
27C	02-0032	Washer, Rubber, 1.000 OD			
27D	30-5113/01	Agitator Motor Bracket			
27E	04-0059	Screw, 8 - 36 x 0.375			
27F	05-0424/01	Agitator Fan			
27G	06-0633	Label, 115V/60Hz, 25W			
28	52-0740	Fan Motor Assy, 115V/60Hz			
28A	91-0017	Fan Motor, 115V/60Hz			
28B	07-0257	Fan Blade			
28C	30-0043	Bracket, Fan Motor			
28D	04-0059	Screw, 8 - 36 x 0.375			
28E	04-0060	Nut, Fan Blade			
28F	02-0413	Silencer, Fan Blade			
28G	06-0667	Label, 115V/60Hz, 35W			
29	11-0118	Connector, Ground			
30	47-2033/01	Tube, Suction			
31	47-0344	Tube, Process			
32	04-0070	Screw, 10 - 24 x 1.312			
33	01-1713	Reducer, Fitting, Elbow			
34	52-0878	Wire, Transformer Lead, Primary			
35	52-0879	Wire, Transformer Lead, Primary			

**5.2 2500 REFRIGERATION DECK ASSEMBLY WITH ELECTRONIC ICE BANK CONTROL (EIBC),
R-134A; PN 82-2049E, 230V/50Hz; PN 82-2103E, 115V/60Hz; PN 82-2098E, 240V/60Hz
(INTERNATIONAL ONLY)**

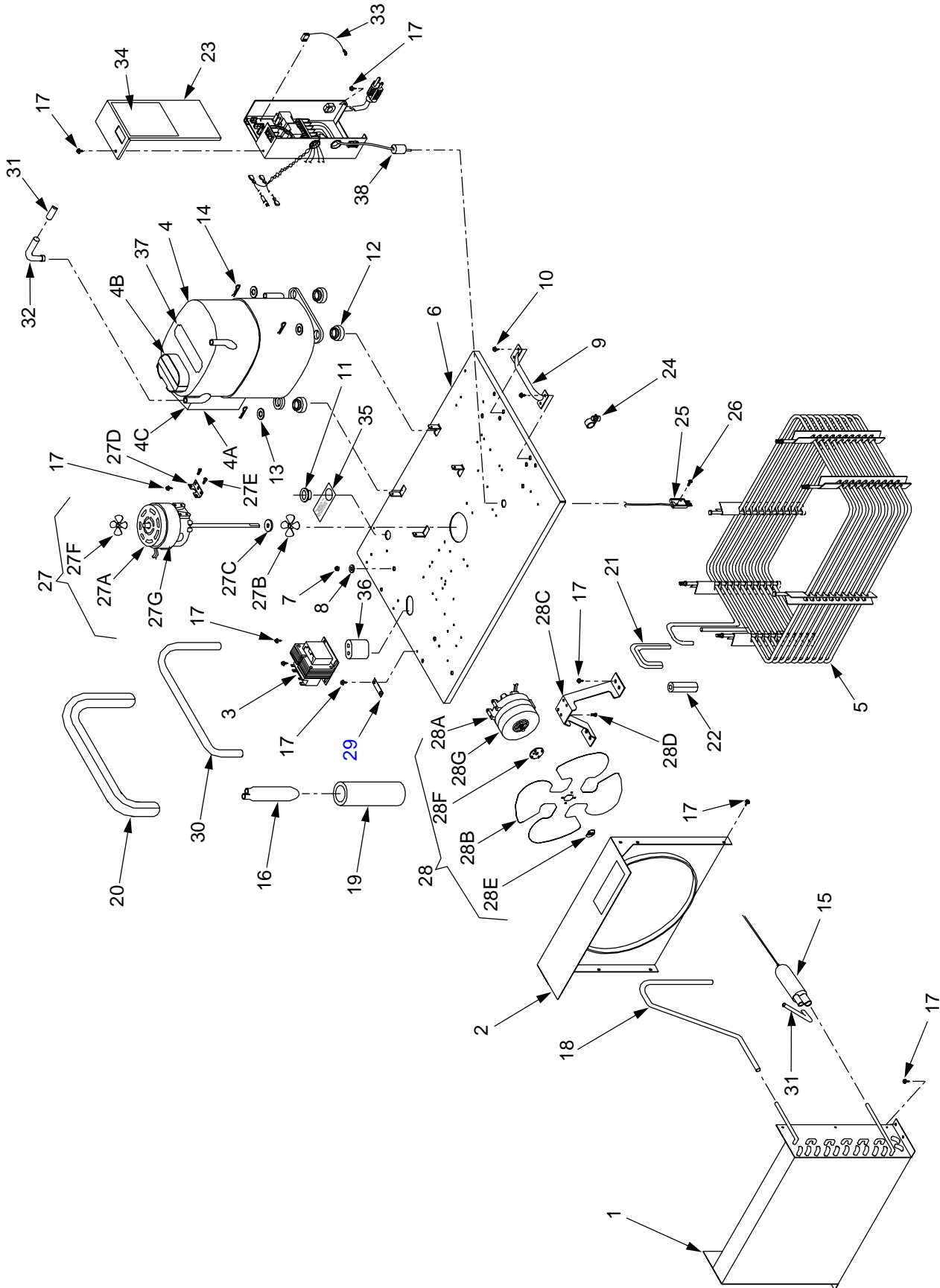

**5.2 2500 REFRIGERATION DECK ASSEMBLY WITH ELECTRONIC ICE BANK CONTROL (EIBC),
R-134A; PN 82-2049E, 230V/50Hz; PN 82-2103E, 115V/60Hz; PN 82-2098E, 240V/60Hz
(CONTINUED)**

(INTERNATIONAL ONLY)

ITEM	PART NO.	DESCRIPTION	ITEM	PART NO.	DESCRIPTION
1	23-0986	Condenser	28	52-0740	Fan Motor Assy, 115V/60Hz
2	51-0349	Shroud Assy	-	52-0741	Fan Motor Assy, 240V/60Hz
3	25-0047	Transformer, 115V/60Hz	-	52-0742	Fan Motor Assy, 230V/50Hz
-	25-0048	Transformer, 230V/50-60Hz	28A	91-0017	Fan Motor, 115V/60Hz
4	83-0101	Compressor, 115V/60Hz	-	91-0018	Fan Motor, 230V/50Hz
-	83-0102	Compressor, 230V/50Hz	-	91-0019	Fan Motor, 240V/60Hz
-	83-0103	Compressor, 240V/60Hz	28B	07-0257	Fan Blade
4A	12-0233	Start Capacitor, 115V/60Hz	28C	30-0043	Bracket, Fan Motor
-	12-0235	Start Capacitor, 230V/50Hz	28D	04-0059	Screw, 8 - 36 x 0.375
-	12-0246	Start Capacitor, 240V/60Hz	28E	04-0060	Nut, Fan Blade
4B	12-0227	Overload, 115V/60Hz	28F	02-0413	Silencer, Fan Blade
-	12-0045	Overload, 230V/50Hz	28G	06-0667	Label, 115V/60Hz, 35W
-	12-0043	Overload, 240V/60Hz	-	06-0668	Label, 230V/50Hz, 35W
4C	12-0232	Relay, 115V/60Hz	-	06-0669	Label, 240V/60Hz, 35W
-	12-0236	Relay, 230V/50Hz	29	11-0118	Connector, Ground
-	12-0247	Relay, 240V/60Hz	30	47-2033/01	Tube, Suction
-	-----	Refrigerant, R134A Only; 115V/60Hz and 240V/60Hz, 15.50 Ounces; 230V/50Hz, 15.75 Ounces	31	47-0344	Tube, Process
5	23-1205	Evaporator Coil Assy	32	01-1713	Reducer, Fitting, Elbow
6	82-0675	Compressor Deck Assy	33	52-2027	Harness Assy, EIBC Ground
7	04-0032	Nut, 1/4 - 20	34	06-1542	Wiring Diagram, Label, EIBC
8	04-0063	Washer, 0.260 ID x 0.687 OD, SS	35	06-0856/01	Fill Hole Label
9	07-0268	Deck Handle	36	02-0040	Seal, Extrusion
10	04-0260	Screw, 10 - 16 x 0.625	37	06-0663	Label, 115V/60Hz, 3/4HP
11	04-0538	Fill Hole Plug	-	06-0664	Label, 230V/50Hz, 3/4HP
12	02-0114	Grommet, Compressor	-	06-0665	Label, 240V/60Hz, 3/4HP
13	04-0537	Washer, Compressor	38	02-0041	Seal
14	03-0150	Retainer Clip, Compressor			
15	23-0999	Dryer/Capillary Tube Assy			
16	51-5400	Accumulator			
17	04-0504	Screw, 8 -18 x 0.375			
18	47-2064	Tube, High Side			
19	50-0105	Accumulator Insulator Boot			
20	50-0106	Insulation, Low Side			
21	50-0107	Insulation, Evaporator Outlet			
22	50-0108	Insulation, Evaporator Inlet			
23	52-2026	Control Housing Assy, EIBC			
24	03-0049	Cord Clip			
25	52-1773	Probe Assy, EIBC			
26	04-0394	Screw, 6 -32 x 0.500			
27	52-1259	Agitator Motor Assy, 115V/60Hz			
-	52-1118	Agitator Motor Assy, 220-240V/50-60Hz			
27A	91-0083	Motor, Agitator, 115V/60Hz			
-	91-0086	Motor, Agitator, 230V/50Hz and 240V/60Hz			
27B	05-0502	Propeller, Agitator			
27C	02-0032	Washer, Rubber, 1.000 OD			
27D	30-5113/01	Agitator Motor Bracket			
27E	04-0059	Screw, 8 - 36 x 0.375			
27F	05-0424/01	Agitator Fan			
27G	06-0633	Label, 115V/60Hz, 25W			
-	06-0634	Label, 230V/50-60Hz, 25W			

5.3 2500 CONTROL HOUSING ASSEMBLY, ELECTRONIC ICE BANK CONTROL (EIBC), INTERNATIONAL ONLY

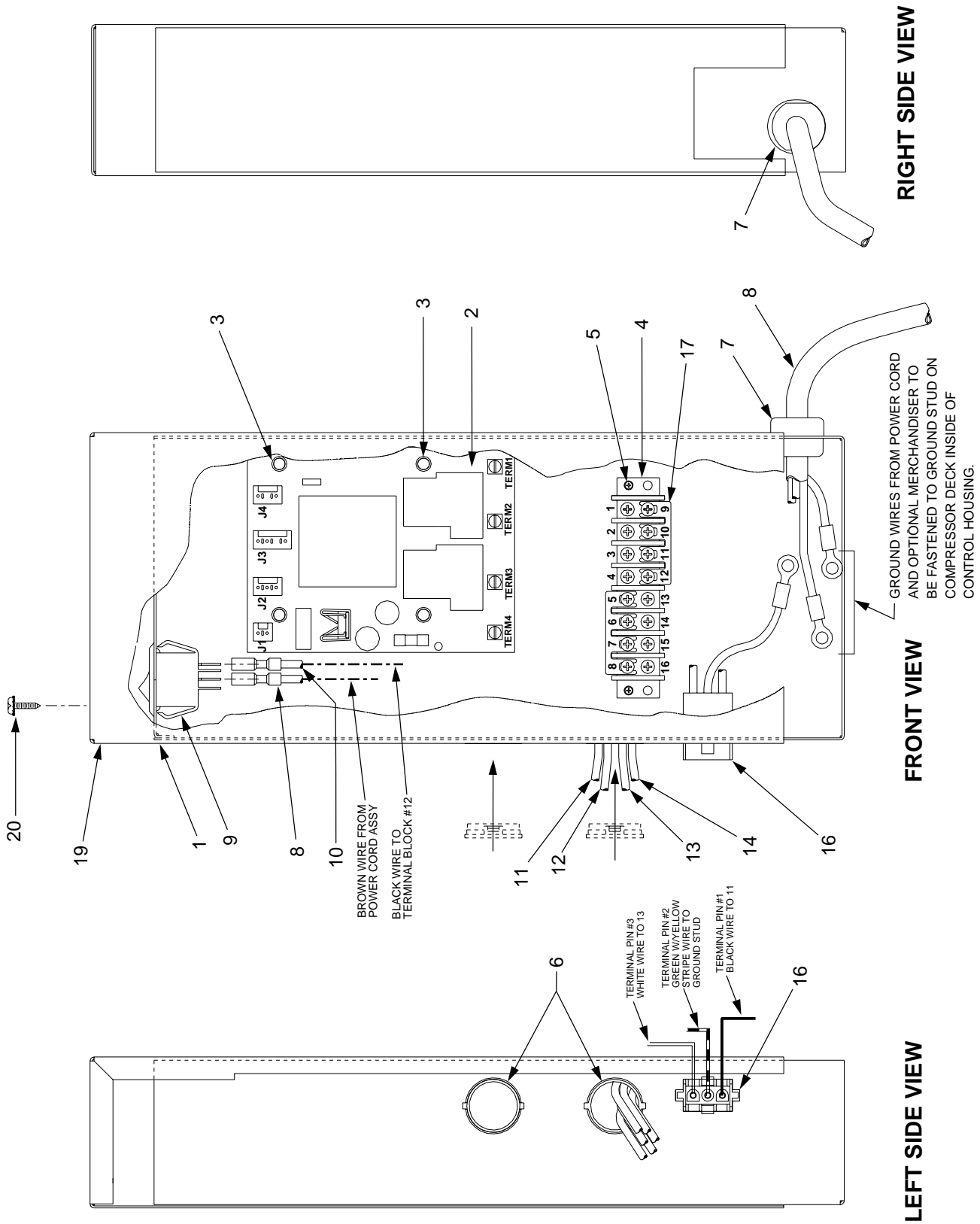

**5.3 2500 CONTROL HOUSING ASSEMBLY, ELECTRONIC ICE BANK CONTROL (EIBC)
INTERNATIONAL ONLY (CONTINUED)**

**5.3.A CONTROL HOUSING ASSEMBLY, EIBC,
PN 52-2026, WITHOUT KILL SWITCH**

ITEM	PART NO.	DESCRIPTION
1	30-7012	Housing, Control
2	52-1423	PCB Assy
3	13-0047	Stand Off
4	12-0190	Block, Terminal
5	04-0477	Screw, 8 - 32, ROLOK
6	13-0059	Bushing
7	13-0028	Strain Relief
8	52-2057	Power Cord Assy
9	-----	Not Applicable
10	-----	Not Applicable
11	52-2021	Lead Assy, Transformer, Primary, #1
12	52-2022	Lead Assy, Transformer, Primary, #2
13	52-2023	Lead Assy, Compressor, #1
14	52-2024	Lead Assy, Compressor, #2
15	52-2061	Lead Assy, EIBC
16	52-1210	Harness Assy, Optional Merchandiser
17	11-0186	Jumper
18	52-1058	Harness, Transformer, Secondary
19	30-7015	Cover, EIBC, Box Without Kill Switch
20	04-0504	Screw, 8 -18 x 0.375

WIRING CONNECTION CHART		
PART NO.	DESCRIPTION	TERMINAL
52-1219 with Kill Switch	Power Cord (BLU)	15
	Power Cord (GRN/YEL)	Ground Stud
	Power Cord (BRN)	Kill Switch (A-A)
52-1218 without Kill Switch	Power Cord (BLU)	15
	Power Cord (GRN/YEL)	Ground Stud
	Power Cord (BRN)	12
52-2038	Lead, Kill Switch, 14 GA (BLK)	12
52-2021	Lead,Trans, Pri #1 (BLK)	3
52-2022	Lead,Trans, Pri #2 (BLK/WHT)	3
52-2058	Harness,Trans, Sec (BLK)	J1
	Harness,Trans, Sec (WHT)	
52-2023	Lead,Comp, #1 (BLK)	Terminal 1
52-2024	Lead,Comp, #2 (BLK/WHT)	6
52-1773	IBC Probe Assy	J2
52-1259	Lead, Agitator Motor (BLK)	10
52-0742	Lead, Agitator Motor (BLK-RIDGED)	14
52-1210	Harness, Optional Merchandiser (BLK)	11
	Harness, Optional Merchandiser (GRN/YEL)	Ground Stud
	Harness, Optional Merchandiser (WHT)	13
52-2061	Lead Assy, EIBC, 2500	Terminal 2 to 1

5.4 2500 CABINET ASSEMBLY

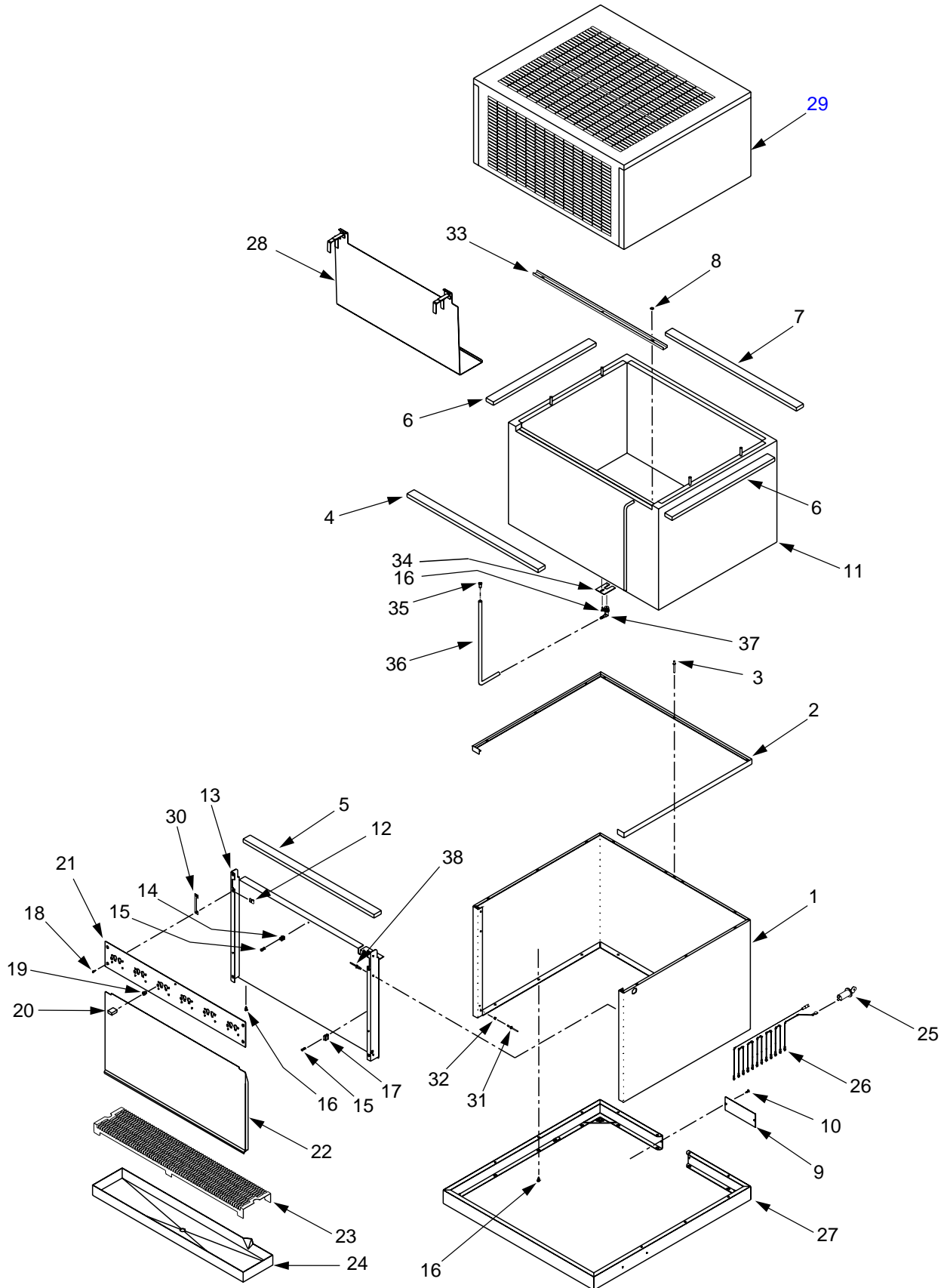

5.4 2500 CABINET ASSEMBLY (CONTINUED)

ITEM	PART NO.	DESCRIPTION	ITEM	PART NO.	DESCRIPTION
1	30-0643/01	Wrapper, External			
2	51-0547	Trim, Gray			
3	04-0067	Rivet			
4	50-0175	Insulation, 1/2 inch			
5	50-0180	Insulation, 1/2 inch			
6	50-0102	Insulation, 1/8 inch			
7	50-0184	Insulation, 1/8 inch			
8	04-0082	Nut, Hex, 10 - 24, SS			
9	30-0612	Back Plate			
10	04-0477	Screw, 8 - 32 x 0.375 inch			
11	42-0013	Tank, Foamed			
12	04-0074	Nut, Clip, 10 - 24			
13	30-0649/02	Front Support Plate			
14	03-0036	Clip, Drain Tube			
15	04-0077	Screw, #4 x 1/4 inch			
16	04-0061	Screw, #8 x 1/2 inch			
17	03-0115	Clip, Overflow Tube			
18	04-0443	Screw, 10 - 24 x 0.375			
19	13-0005	Bushing, Strain Relief			
20	11-0015	Connector Housing			
21	23-0391	Faucet Plate, 8-Valve			
--	23-0605	Faucet Plate, 6-Valve			
--	30-6702	Faucet Plate, 6-Valve, Premix			
--	30-6703	Faucet Plate Stiffener, 6-Valve, Premix			
22	30-6640	Splash Plate			
23	30-0535	Cup Rest			
24	23-0306	Drip Tray			
25	12-0097	Key Lock Switch			
26	52-0893/01	Harness Assy, 8-Valve			
--	52-1214	Harness Assy, 6-Valve			
27	51-0582	Base Assy			
28	82-1120	Insulator Plate Assy			
29	23-0443/02	Bonnet Assy (Specify Graphics)			
30	30-5314	Shim Plate			
31	04-1012	Rivet, Splash Plate Spacer			
32	01-1705	Spacer, Splash Plate			
33	30-5599/02	Retainer, Cage, 2500			
34	30-5143	Clip, Drain			
35	01-0450	Tube Support			
36	08-0190	Drain Tube			
37	01-1483	Elbow Drain Assy			
38	04-0072	Rivet			

NOTE: Cage Assembly Part Numbers are:

23-1232/01	6-Valve, 3-2-1 Manifold, 3/8 inch Syrup Inlets
23-1236/01	8-Valve, 3-1-1-3 Manifold, 3/8 inch Syrup Inlets
23-0919	4-Circuit Chiller
23-0798/01	9-Circuit Chiller
23-1103	6-Valve Premix

5.5 2500 WIRING DIAGRAM AND HOUSING CONNECTIONS, LANCER ELECTRONIC ICE BANK CONTROL, USA ONLY

IMPORTANT

WHEN STARTING UNIT OR IF CURRENT IS INTERRUPTED, THERE IS A FIVE (5) MINUTE DELAY BEFORE THE COMPRESSOR/FAN STARTS.

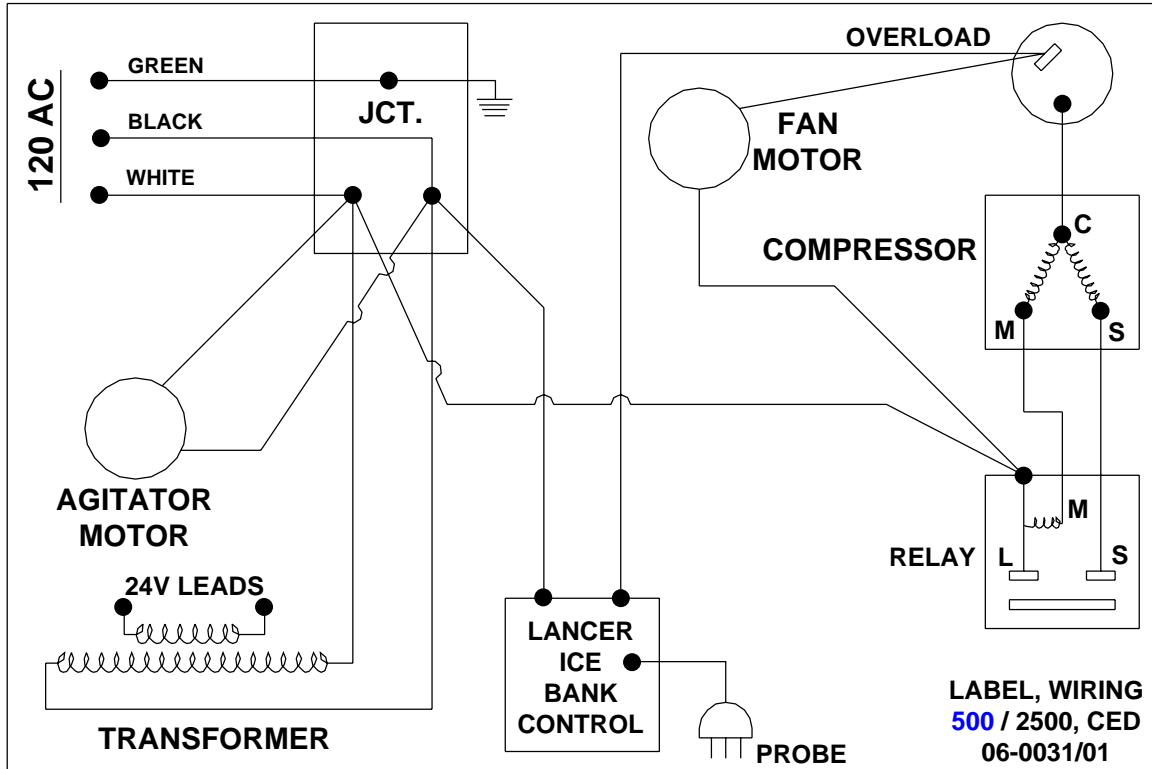

LABEL, WIRING DIAGRAM, CED, PN 06-0031/01

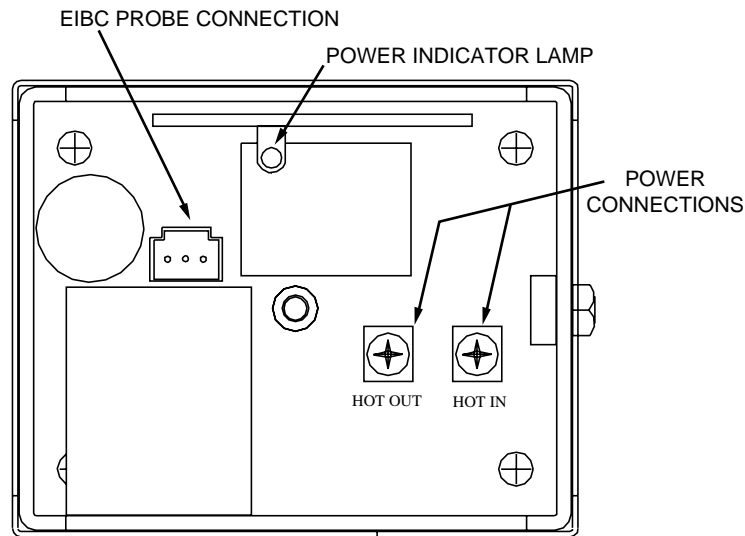

CONTROL HOUSING CONNECTIONS

IMPORTANT

WHEN STARTING UNIT OR IF CURRENT IS INTERRUPTED, THERE IS A FIVE (5) MINUTE DELAY BEFORE THE COMPRESSOR/FAN STARTS.

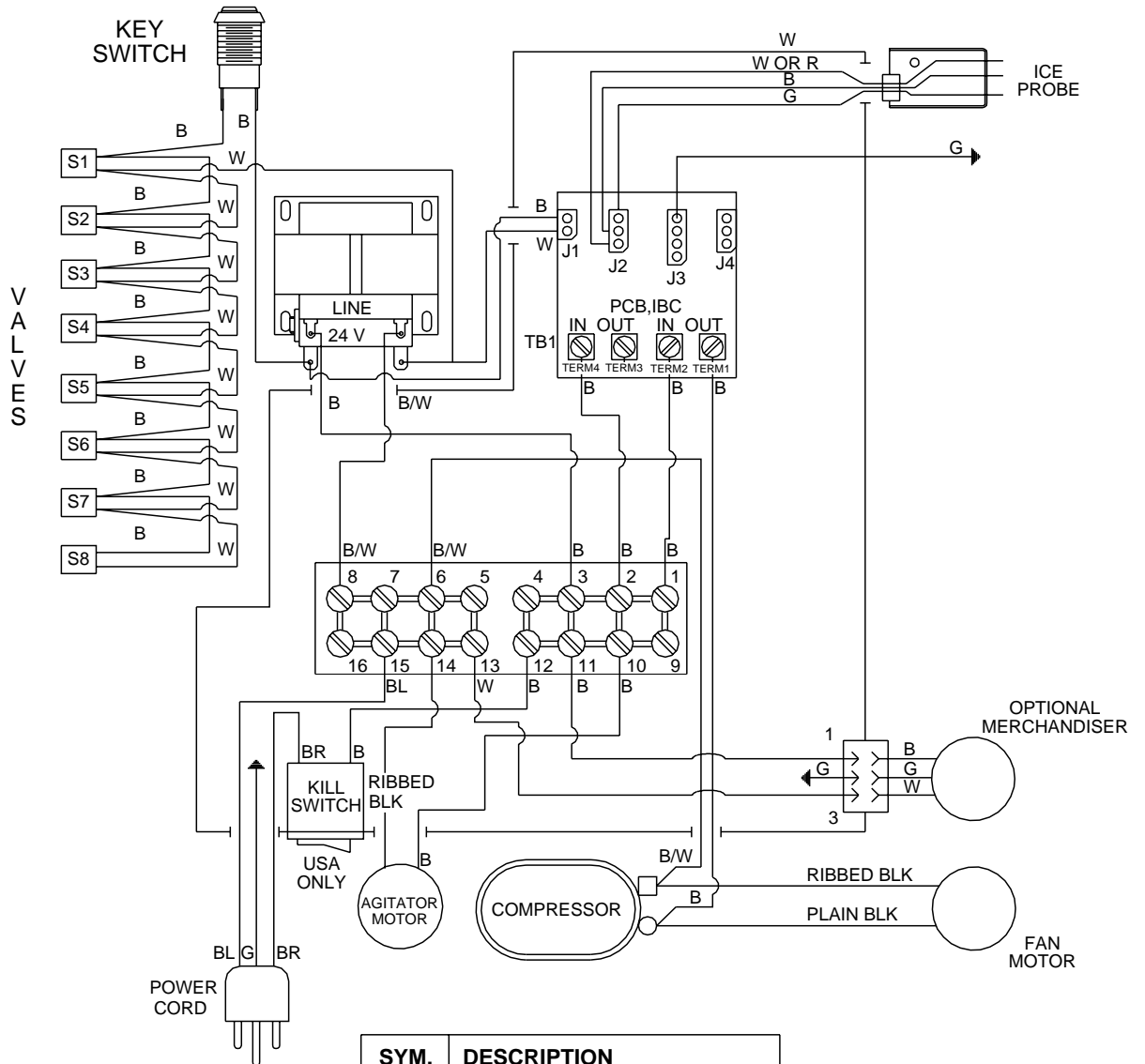

SYM.	DESCRIPTION
	CHASSIS GROUND
	CONTROL BOX
	CHAMFER PIN 1

LANCER LABEL,
WIRING DIAGRAM
06-1542

5.7 INSTALLATION KITS AND OPTIONAL ACCESSORIES

<u>PART NUMBER</u>	<u>DESCRIPTION</u>
• 82-1796	BIB Installation Kit - For 3/8 Inch Syrup Inlets
• 82-0221-06	FIGAL Installation Kit - 6 Valve - For 1/4 Inch Syrup Inlets
• 82-0221-08	FIGAL Installation Kit - 8 Valve - For 1/4 Inch Syrup Inlets
• 82-2613-06	FIGAL Installation Kit - 6 Valve - For 3/8 Inch Syrup Inlets
• 82-2613-08	FIGAL Installation Kit - 8 Valve - For 3/8 Inch Syrup Inlets
• 82-0344	Leg Kit
• 82-2139	EIBC Retrofit Kit - International Only
• 82-2572	ELS Marquee Kit - Graphics Included
• 82-1802	24VAC Lighted Marquee (Graphics Ordered Separately)
• Marquee Graphics for PN 82-1802 Only	
• 06-1790	Coca-Cola Dynamic Ribbon, Screened
• 06-1789	Coca-Cola Three Cup, "Taste Real Refreshment", Duratrans

*(Continued from previous page)***PromoVen, S.A. - Argentina**

Contact: Rafael Mendoza
 Junca 858 - Piso 3 Depto. "L"
 (1062) Buenos Aires
 Argentina
 Phone: (54.11)4394.7654
 FAX: (54.11)4394.1193
 e-mail: promoven@customw.com.ar

Bras Sulamericana LTDA. - Brasil

Contact: Fabio Queiroz
 Rua. Dr. Ladislau Retti, 1400
 Parque Alexandre
 Cotia Sao Paulo - Brasil
 CEP: 06714-150
 Phone: 55-11-4612-1122
 FAX: 55-11-4612-2219
 e-mail: fabio.queiroz@bras.com.br

Lancer Chile Ltda. - Chile

Contact: Heriberto Concha
 Vicuna Mackenna 3019, San Joaquin
 Santiago, Chile
 Phone: 56-2-552-1657
 FAX: 56-2-552-1961
 e-mail: chocha@lancer.tie.cl

Lancer Pacific**International Sales**

6655 Lancer Blvd.
 San Antonio, TX 78219
 Phone: (210) 310-7000
 FAX: (210) 310-7242
 1-800-729-1500
 e-mail: asia@lancercorp.com

Australia

Lancer Pacific Pty Ltd
 5 Toogood Avenue
 Beverley 5009
 South Australia
 Phone: 61-8-8268-1388
 FAX: 61-8-8268-1978
 e-mail: ian-lunniss@lancer-pacific.com.au
 (General Manager, Lancer Pacific)
 steve-sotiriou@lancer-pacific.com.au
 (for Fountain)
 fiore-alvaro@lancer-pacific.com.au
 (for Beer)

Lancer Pacific Pty Ltd
 7 Slough Avenue
 Silverwater 2128
 New South Wales
 Australia
 Phone: 61-2-9648-6840
 FAX: 61-2-9648-6850
 e-mail: neild-mcintosh@lancer-pacific.com.au
 (Managing Director)
 john-frize@lancer-pacific.com.au
 (NSW State Manager)

Lancer Pacific Pty Ltd
 55 Keele Street
 Collingwood 3066
 Victoria
 Australia
 Phone: 61-3-8415-1920
 FAX: 61-3-8415-1929
 e-mail: bill-cadd@lancer-pacific.com.au

Lancer Pacific Pty Ltd
 Unit 31, 284 Musgrave Drive
 Coopers Plains 4108
 Queensland
 Australia
 Phone: 61-7-3274-5700
 FAX: 61-7-3875-1805
 e-mail: brett-thomson@lancer-pacific.com.au

New Zealand

Lancer Pacific Ltd
 9 O'Rorke Street
 Onehunga, Auckland
 New Zealand
 Phone: 64-9-634-3612
 Mobile Phone: 64-21-745-389
 FAX: 64-9-634-1472
 e-mail: mike-peffers@lancer-pacific.com.au
 andrew-nixon@lancer-pacific.com.au

Lancer Asia**Hong Kong**

1001 Technology Plaza
 651 King's Road
 North Point
 Hong Kong
 Patrick Co - Area Manager - Asia
 Phone: 852-2214-9195
 Rob Burdock - Senior Director - Asia
 Phone: 852-2214-9196
 FAX: 852-2214-9448
 e-mail: rob-burdock@lancer-asia.com
 patrickco@lancer-asia.com

Lancer Authorized Distributors**Shanghai Freser International Co Ltd. - China**

1856, Hu Tai Road
 Shanghai, 200436, China
 Phone: 86-21-5650-3555
 FAX: 86-21-5650-2666
 e-mail: daniel@freser.com.cn

Freser (HK) Company Ltd - Hong Kong

Flat A, 24/F., Houston Industrial Bldg.
 32-40 Wang Lung Street
 Tsuen Wan, N. T., Hong Kong
 Phone: 852-2408-2595
 FAX: 852-2408-2605
 e-mail: freserhk@netvigator.com

P.T. Dikarunia Sejahtera - Indonesia

Jl. Gelong Baru Tengah #1A, Tomang
 Jakarta, Barat 11440, Indonesia
 Phone: 62-21-5694-3242
 62-21-5437-2534
 FAX: 62-21-5694-3242
 e-mail: dikarunia@cbn.net.id

Hayakawa Sanki - Japan

Hayakawa Sanki, Inc.
 1-13-13, Kayaba-cho
 Nihonbashi, Chuo-ku
 Tokyo, 103-0025
 Japan
 Phone: 03-5651-1481
 FAX: 03-5651-1445
 e-mail: SANKI10217@aol.com

Tahoe Corporation - Korea

Tahoe Corporation
 2FL, 835-66 Yocksam-dong
 Kangnam-Ku
 Seoul, Korea
 Phone: 82-2-557-5612, -5614
 FAX: 82-2-557-5615
 e-mail: tahoe@empal.com

Freser (MALAYSIA) SDN. BHD. - Malaysia

No. 31, Jalan TPP 5/13, Taman
 Perindustrian Puchong, Seksyen 5,
 47100 Puchong, Selangor, Malaysia
 Phone: 60-3-8061-6666
 FAX: 60-3-8062-1007
 e-mail: freser@tm.net.my

R.B.P. Industrial Sales Inc - Philippines

Unit 20, Facilities Centre Bldg.
 548 Shaw Blvd
 Mandaluyong City, Philippines
 Phone: 632-531-1215/1221/1289
 FAX: 632-531-1271
 e-mail: rbpsales@pltdsl.net
 rbp@pltdsl.net

Freser (S) Pte Ltd - Singapore

Blk 998 Toa Payoh North
 #04-12/14
 Singapore 318993
 Phone: 65-6352-0943
 FAX: 65-6352-8594
 e-mail: fresersin@pacific.net.sg

Freser International Corporation - Taiwan

No. 76, Gui-Sui Street
 Taipei 103, Taiwan R.O.C.
 Phone: 886-2-2553-1555
 FAX: 886-2-2553-2742
 e-mail: herman@intl.freser.com.tw

Freser Makasan International Co., Ltd - Thailand

Freser Makasan International Co., LTD.
 Navanakorn Industrial Estate Zone 4
 95/3 Moo 13, Klongnung, Klongluang
 Patumthani 12120, Thailand
 Phone: 662 520-3457 (Automatic, 7 lines)
 FAX: 662 529-3840
 e-mail: komsan@makasan.co.th

Lancer - Indian Sub-Continent**India**

Shabbir Shafiqui - Area Manager
 India and Sub-Continent
 B-7, Pannalal Silk Mill Compounds
 78, LBS Marg, Bhandup (W)
 Mumbai 400-078, India
 Phone: 91-22-2561-6665
 Cel No.: 91-98-2029-5252
 FAX: 91-22-5637-4018
 e-mail: shafiquis@vsnl.com

Lancer Authorized Distributors**Western Refrigeration Ltd - India**

B-7, Pannalal Silk Mill Compounds
 78 L.B.S. Marg, Bhandup (W)
 Mumbai 400-078, India
 Phone: 91-22-2561-6665
 FAX: 91-22-2562-2257
 e-mail: western@bom5.vsnl.net.in

Bengal Marketing Company - Bangladesh

Skylark Point (6th Floor)
 Room #G-2
 24/A Bijoy Nagar,
 Dhaka-1000, Bangladesh
 Phone: 880-2-934-2987
 FAX: 880-2-935-0127
 e-mail: bmc@dhaka.agni.com

Dynamic Equipment - Pakistan

Dynamic Equipment and Controls (Pvt.) Ltd.
 F-1/23, Canal Cottages, Block-D.
 New Muslim Town.
 Lahore, Pakistan.
 Phone: 0092-42-583-6737
 0092-42-583-6787
 FAX: 0092-42-586-7924
 e-mail: info@dynamic-eqpt.com.pk
 m.ateeq@dynamic-eqpt.com.pk

Lancer USA

Manufacturing Locations

Foster Road Facilities

6655 Lancer Blvd
San Antonio, TX 78219
Phone: (210) 310-7000
MFG FAX: (210) 310-7088
ENG FAX: (210) 310-7096
ACCT FAX: (210) 310-7091
PURCH FAX: (210) 310-7094

Lancer FBD

5620 Business Park
San Antonio, TX 78218
Phone: (210) 666-0544
FAX: (210) 666-2044

Lancer Ice Link

6655 Lancer Blvd
San Antonio, TX 78219
Phone: (210) 310-7174
FAX: (210) 310-7245

Remanufacturing

6655 Lancer Blvd
San Antonio, TX 78219
Phone: (210) 310-7256
FAX: (210) 310-7261
1-800-729-1550

Lancer North America

USA - Canada Sales

6655 Lancer Blvd.
San Antonio, TX 78219
Phone: (210) 310-7000
SALES FAX: (210) 310-7245
CUSTOMER SERVICE FAX: (210) 310-7250
1-800-729-1500

Georgia Office

1125 Northmeadow Parkway, Suite 116
Roswell, GA 30076
Phone: (770) 343-8828
FAX: (770) 475-8646
1-800-729-1750

Lancer Authorized Distributors

Advanced Beverage Solutions (ABS)

100 N. Gary Avenue, Suite C
Roselle, IL 60172
Phone: (847) 524-1707
(877) 814-2271
FAX: (847) 524-1710
www.absone.com

Bevco

6900 Camille Avenue
Oklahoma City, OK 73149
Phone: (405) 672-7770
FAX: (405) 672-7443
e-mail: info@bevcoinc.com

Joe Kirwan Company

119 White Oak Lane
Old Bridge, NJ 08857
Phone: (732) 679-1900
FAX: (732) 679-9236
e-mail: sales@jkirwan.com

L & M Beverage Equipment Co. Inc.

12510 Santa Fe Trail Drive
Lenexa, KS 66215
Phone: (913) 888-8988
FAX: (913) 888-9137
e-mail: L7mco@aol.com

(Update #51 - as of July 22, 2004)

Ernest F. Mariani Company

614 West 600 South
Salt Lake City, UT 84104
Phone: (801) 359-3744
FAX: (801) 531-9615
e-mail: febell@efmco.com, or
clay@efmco.com

Mark Powers & Company, Inc.

P.O. Box 72
1821 Henry Street
Guntersville, AL 35976
Phone: (256) 582-6620
FAX: (256) 582-8533
e-mail: sales@markpowers-and-
company.com

Maurer Supply, Inc.

843 Rainier Avenue South
Seattle, WA 98144
Phone: (206) 323-8640
FAX: (206) 323-9286
e-mail: maurersupply@qwest.net

Simgo Ltd.

5122 Timberlea Blvd.
Mississauga, Ontario L4W 2S5
Canada
Phone: 905-602-5800
FAX: 905-602-5804
e-mail: simgo@simgo.com

Simgo (B.C.) Ltd.

16-8125 - 130th Street
Surrey, B.C. V3W 7X4
Canada
Phone: 604-590-4022
FAX: 604-590-1601

Lancer Europe

Belgium - European Central Office

Lancer Europe, S.A.
Mechelsesteenweg 52
B-1930 Zaventem
Belgium
Phone: 32-2-755-2390
FAX: 32-2-755-2399
e-mail: lancer.europe@glo.be

England

Managing Director
Contact: Paul Haskayne
Lancer G.B. Llp.
Unit 9 Prosperity Court, Midpoint 18
Middlewich CW10 OGD
Cheshire, United Kingdom.
Phone: 441606837711
FAX: +441606832705
e-mail: phaskayne@lancergb.co.uk

17 Bembridge Gardens
Ruislip, Middlesex
HA4 7ER, England
Phone: 44-1895672667
FAX: 44-1895637537
e-mail: court4lancer@msn.com

Hungary

H-2100 Gödöllő
Isaszegi út 67
Hungary
Phone: 36-28-417-179
FAX: 36-28416-881
e-mail: bodolai@compuserve.com

Lancer Authorized Distributors

Complete Beverage Services, Ltd.
Republic of Ireland and Northern Ireland
Gortrush Industrial Estate
Omagh County Tyrone
Northern Ireland
Office: 44-1662 250 008
FAX: 44-1662-252-991

Provisiona, S.L. - Spain

Avda. Concha Espina 8
28036 Madrid Spain
Phone: 34-91-564 6900
FAX: 34-91-564 3065
e-mail: jmorales@bevserve.com

Lancer Russia

Lancer International Sales, Inc.

Representation Office
Kashirskoe shosse, 65 (1), Office 505
Moscow 115583 Russia
Mail: Moscow, 115551, Mail Box #2, Russia
Mobile Phone: 7-095-991-7778
Office Phone: 7-095-727-4063
Office FAX: 7-095-727-4064
e-mail: vdemkin@ktv.ru
lancer@online.ru

Lancer Middle East / Africa

Elsayed Moniem - Regional Manager
Lancer Middle East/Africa
7 Mubarak Street
East Ain Shams 11311
Cairo, Egypt
Phone: 2-02-49-35-395
FAX: 2-02-49-33-914
Mobile Phone (GSM): 2-010-500-4007
e-mail: elsayed_lancer@msn.com

Lancer Authorized Distributor

DispenseTech - South Africa

P.O. Box 17495
Sunward Park, 1470
South Africa
Phone: 27-11-397-7455
FAX: 27-11-397-7648
e-mail: david@dispensetech.co.za

Lancer Latin America

Latin America Sales

6655 Lancer Blvd.
San Antonio, TX 78219
Phone: (210) 310-7000
FAX: (210) 310-7245
1-800-729-1500
e-mail: latinamerica@lancercorp.com

Lancer de México, S.A. de C.V.

Contact: Gerardo Canales
Calle Lerdo De Tejada #544 PTE.
Col. Las Villas
San Nicolas De Los Garza, N.L.
Monterrey, N. L., México C.P. 66422
Phone: (52)-81-83-52-85-32
Phone: (52)-81-83-52-85-34
Phone: (52)-81-83-52-53-60
FAX: (52)-81-83-32-54-10
e-mail: direccion@lancer.com.mx

PEL SudAmerica - Ecuador

Lancer Sales Company
Contact: Luciano Lopez
Sector Las Acacias
Luis De Beethoven #958
Y Capitan Rafael Ramos
Quito, Ecuador
Phone: 593-22-401-598, 400-937, 406-418
FAX: 593-22-400-535
e-mail: Llopez@ecnet.ec

Lancer Authorized Distributors

Eximport & Barter Co. - Caribbean

2101 S.W. 56th Terrace
Hollywood, FL 33023 USA
Phone: (954) 967-9999
FAX: (954) 967-9900
e-mail: edbrandao@aol.com

(Continued on reverse)