

Aladdin Temp-Rite[®]...better by degrees.

P.O. Box 2978, Hendersonville, TN 37077-2978
1-800-888-8018 or 615-537-3600
Fax 1-888-812-9956
www.aladdintemprite.com



DH07, DH08 CONVECTED AIR DISH HEATERS (9" Dishware)



INSTALLATION, OPERATION & MAINTENANCE MANUAL

Manual P/N 92448
Rev. O 06/27/2016

DH07 / DH08 CONVECTED AIR DISH HEATERS (9" Dishware)

CONTENTS

I. MODELS 4

II. RECEIVING INSPECTIONS 5

III. INSTALLATION 5

IV. ELECTRICAL 6

V. START-UP 7

VI. CLEANING 8

VII. TROUBLESHOOTING 9

VIII. PARTS LIST/DIAGRAMS 10

IX. PREVENTATIVE MAINTENANCE 14

X. SERVICE 15

XI. WARRANTY 15

I. MODELS

The Aladdin Convected Air Dish Heaters are available in two capacities. These units are designed specifically for use with a wide variety of 9" china and Alacite® dishware only.

(Not recommended for any type of pellet bases.)

The Aladdin Convected Air Dish Heaters are mobile, modularly designed products which are able to be used independently or in conjunction with other units in a tray line arrangement.

Aladdin Sales Codes	DH07	DH08
Number of Stacks	2	3
Capacity per Stack	60	60
Capacity (Total)	120	180
Overall Dimensions:		
Length	32.58" (82.75 cm)	46.0" (116.8 cm)
Width	24.60" (62.48 cm)	24.60" (62.48 cm)
Height	42.86" (108.86 cm)	42.86" (108.86 cm)
Electrical Requirements:		
Voltage / Phase	208-240V /1	208-240V /1
Amperage	16	16
Cycle	60	60
NEMA Plug Configuration	6-20P	6-20P
Approximate Shipping Weight	270 lbs.	300 lbs

II. RECEIVING INSPECTIONS

You should carefully inspect your Dish Heater to assure that no damage has occurred in transit. If however, damage is detected see the following damaged goods policy. Under no condition may a damaged unit be returned to Aladdin Temp-Rite without first obtaining written permission (return authorization). No credit will be issued for claims not reported to Aladdin within ten (10) business days from receipt of shipment.

ALADDIN DAMAGED GOODS POLICY

There are two types of damaged merchandise:

- Visual Damage
- Concealed Damage

Visual Damage – When the product being received is visibly damaged.

1. Receiver should not accept merchandise with visual damage.
2. Receiver must sign delivery receipt “refused merchandise due to damage” and specify damage.
3. Receiver should call Aladdin Customer Service immediately after refusal.
4. Carrier will notify Aladdin Traffic Department and a claim will be filed.
5. Carrier will send acknowledgement of claim within 7 days after receiving.

Concealed Damage – When damaged merchandise cannot be externally detected.

Any receiving operation should be looking for this type of damage. Sometimes, however, depending on the type of product, it is almost impossible to notice.

1. Merchandise must not be removed from point of delivery and all packaging must be kept intact.
2. Receiver must contact Aladdin customer service to report damage.
3. Aladdin traffic department will request inspection based on the dollar value of the cargo.
4. Aladdin traffic department will file a claim based on the findings of the inspection.

Failure to comply with these policies will result in the customer’s responsibility to file claims.

III. INSTALLATION

NOTE: The installation instructions are similar for all the heaters.

- A. **All models are equipped with a self-leveling mechanism that is removable through the top of the unit so that adjustments can be made to the tension springs. By adding or removing springs, the proper dispensing height can be obtained.** Refer to the table on page 7 to adjust the DH07 or DH08 to dispense either 9" china or Alacite® dishes. (The heaters are factory preset for china dispensing) Adjustments should be done as part of the initial equipment set-up or when a change of dinnerware occurs.

- B. If you are dispensing Alacite® dishes a spring adjustment will be required, proceed as follows. Lift elevating mechanism assembly up and out of stainless steel cabinet. Set it on the floor. Disconnect but do not remove any unnecessary springs from the elevator carrier and replace mechanism back into the heater. (See chart on page 7 for correct spring arrangement.)

- C. See **ELECTRICAL** (section IV) and **START-UP** (section V) before plugging unit into power supply.

IV. ELECTRICAL

Refer to the specifications data on page 4, the serial tag, your local code or the National Electrical Code to be sure the unit is connected to the proper power source. A protected circuit of the correct voltage and amperage must be available for connection of the line cord. All dish heaters are provided with a NEMA plug type 6-20P.



Every heater is fitted with a grounded power cord and must be connected to a properly grounded receptacle. Each receptacle must be wired to a dedicated circuit breaker rated at not more than 20 amps.



To prevent electrical shock hazard, the main power switch must be turned to "off" position and the heater disconnected from the power source whenever performing service or maintenance.



Hazardous voltage inside back of cabinet. Only qualified personnel totally familiar with electrical circuits, service manual and service procedures should open or work inside unit.

V. START-UP

A. OVERVIEW

These units are designed to heat china or Alacite® plates. Once the unit is turned on, the fan motor, heater and power indicator light will come on. There is a power indicator light to let the operator know the power is on. The fan motor will begin to circulate the heated air in and around the plates in a convection process that promotes a quick and even heat absorption by the dinnerware.

Once the air inside the cabinet has reached the desired and preset temperature, the thermostat will continue to maintain this temperature by regulating the power to the heater. The fan motor will run as long as the unit is energized.

B. LOADING

Load carrier tray by carefully stacking the dishes in each cavity. Always keep the load leveled on the carrier or it may bind. Never try to exceed the recommended dish capacities that are shown in the chart below. The fan motor will begin to circulate the heated air in and around the plates in a convection process that promotes a quick and even heat absorption by the dinnerware.

 **WARNING** 

Do not adjust thermostat above 190° for Alacite® plates as this may cause yellowing and/or damage to the plates..

 **CAUTION** 

No type of pellet base should be heated in these dish heaters. Failure to observe this warning could result in damage to bases or risk of fire.

Round Plates					
Style	Dimensions	Aladdin Sales codes	Springs Required	Total Capacity	
				DH07	DH08
China	9" Diameter	J300	8	120	180
	9" Diameter	J361	8	120	180
	9" Diameter	J461	8	120	180
	9" Diameter	J561	8	120	180
	9" Diameter	J700	8	120	180
	9" Diameter	J100	8	120	180
Alacite	9" Diameter	K95	6	120	180
	9" Diameter	K97	6	120	180
	9" Diameter	K98	6	120	180
	9" Diameter	J420	4	86	129

C. POWER

Set the power switch to the "ON" position. The power switch will light up when the unit is on.

Keep the cover closed completely to insure proper and efficient heating.

Depending on the stack size, and dish material, the heating time will vary. **The heater should always be turned on 60 to 90 minutes before dispensing.** Generally, china dishes will heat quicker than Alacite®.

D. DISPENSING



After the unit is turned off or unplugged, the dishes remaining inside the unit will remain hot for some time. Leave the lid open to allow the unit and its contents to cool.

E. ADJUSTING THE THERMOSTAT

All models are shipped with a factory preset of 190°F (Max setting 220°F). The thermostat can be adjusted, by dial control located behind the rear panel, to adjust

1. Unplug the unit
2. Remove the rear cover
2. Adjust thermostat dial to the desired setting
3. Replace the rear cover
4. Plug unit back in to an outlet

VI. CLEANING

The following procedures should be followed during the regular cleaning regimen on all of the dish heaters.

1. Turn the unit off and disconnect the plug from the outlet, and allow the cabinet to cool.
Remove plug by pulling it straight out. Never pull on the cord.
2. Pull the elevator mechanism up and out, place it on a work surface.
You can now wipe down the mechanism with a damp cloth to clean it.
3. Clean out any debris inside the cabinet and wipe the cabinet down with a damp cloth.
4. Place the elevator mechanisms back inside the cabinet and clean the outside of the cabinet with a mild, non-abrasive soap or detergent in a warm water solution. A commercial stainless steel cleaner can also be used for this procedure.
5. After the heater has been thoroughly cleaned and dried with a soft cloth the plug can be replaced.

NOTE: Do not use abrasives, harsh chemicals, or chlorine products for cleaning.



WARNING



Do not steam or pressure clean or hose down the cabinet. This could damage the equipment and possibly cause an electrical shock to the operator.



WARNING



Repairs to be done by qualified service personnel only.

VII. TROUBLESHOOTING

<u>COMPLAINT</u>	<u>PROBLEM</u>	<u>SOLUTION</u>
A. Unit does not operate and no lights are on	1. No power	1. Make sure plug is connected and switch is ON. Check for power to the receptacle
	2. Bad power switch	2. Replace power switch
	3. Loose wiring	3. Check and secure wiring
B. Unit heats, but fan does not operate	1. Defective motor	1. Replace motor
	2. Jammed or loose fan blade	2. Replace or tighten blade
	3. Loose wiring	3. Determine fault and correct
C. Unit does not heat, but fan operates	1. Defective heating element	1. Replace heating element
	2. Open high limit switch	2. Replace switch. Check for causes before restarting equipment
	3. Loose wiring	3. Check and secure wiring
D. Plate temperature is too low, fan operating	1. Thermostat set too low	1. Readjust thermostat
	2. Jammed or loose fan blade	2. Replace or tighten blade
	3. Cover is open	3. Close cover
E. Plate temperature is too high, fan is operating	1. Thermostat set too high	1. Readjust thermostat
	2. Closed thermostat	2. Replace thermostat
	3. Closed high limit switch	3. Replace high limit switch
F. Cover is loose	1. Hinge screws are missing or loose	1. Replace or tighten screws
G. Elevator Binds	1. Improper springs	1. Check springs chart and use correct number of springs. Make sure identical number and size of springs are on each side of elevator
	2. Debris on guide rods	2. Clean off debris
H. Cabinet does not roll easily	1. Debris on wheel or axle	1. Clean out debris
	2. No lubrication	2. Lubricate axles with load bearing grease. Lubricate swivel bearings with 30-weight oil.

VIII. PARTS LIST/DIAGRAMS

ITEM #	DESCRIPTION	ALADDIN PART #	DH07 Qty.	DH08 Qty.
1A	Lid assembly-End (for units prior to Dec 2011)	92496	2	2
1B	Lid assembly-End (for units after Nov. 2011)	11558	2	2
2A	Lid assembly-Center (for units prior to Dec 2011)	92497	-	1
2B	Lid assembly-Center (for units after Nov. 2011)	11559	-	1
3A	Hinge, RH & LH	10173	2	3
3B	Hinge, RH & LH (for units before December 2011)	92203	2	3
4	Switch guard	10570	2	3
5	Lid handle	92500	2	3
6A	Push/Pull handle	99594	1	1
6B	Push/Pull handle (for units before March 2009)	92501	-	-
7	Rear louvered panel DH07	10554	1	-
8	Rear louvered panel DH08	10553	-	1
9	Cord-10 foot length	94837	1	1
10	Plug- NEMA 6-20 straight blade	92504	1	1
11	Plug-NEMA L6-20 twist lock	29781	1	1
12	Switch kit	93989	-	-

ITEM #	DESCRIPTION	ALADDIN PART #	DH07 Qty.	DH08 Qty.
12a	On/off switch	97539	1	1
13	Motor-208/230V,60hz.1ph. 3200 rpm ♣	13064	1	1
13a	Motor conversion kit ♣	13068	-	-
14	High limit switch-257°F manual reset	11760	1	1
14a	High limit (for SN prior to DH07A13136 & DH08A13071)	92507	-	-
15	Thermostat-85-220 °F	92508	1	1
16	Knob, Thermostat-85-220 °F	92509	1	1
17	Heating element-208-240V	92511	1	1
18	na			
19	Fan Blade, 5/16" bore	92512	1	1
20	Caster 5" swivel	97223	2	2
21	Caster 5" swivel with brake	92516	2	2
22	Elevator spring	12405	16	24
23	Elevator bushing	10816	8	12
24	Elevator guide rod	10638	4	6
25	Elevator assembly	92520	2	3
26*	Corner bumpers	93052	4	4

NOTES:

*Corner Bumpers are used in place of wrap around bumpers on units manufactured after August 1999.

♣For the SN and above DH07 F16431 and DH08 E16218

♣For SN prior to DH07 F16431 and DH08 E16218

DH07

EXPLODED VIEW DRAWING

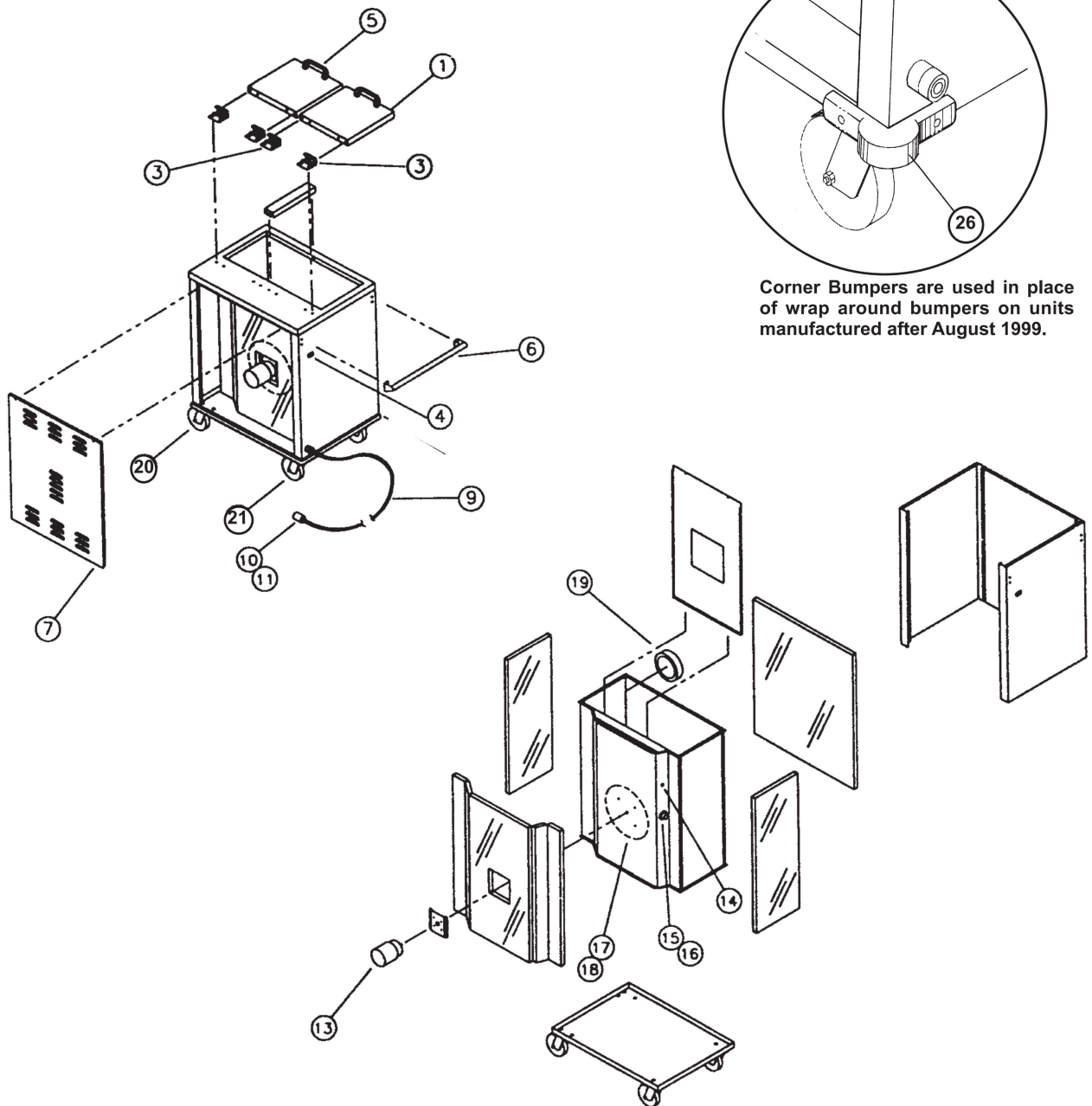

Corner Bumpers are used in place of wrap around bumpers on units manufactured after August 1999.

DH08

EXPLODED VIEW DRAWING

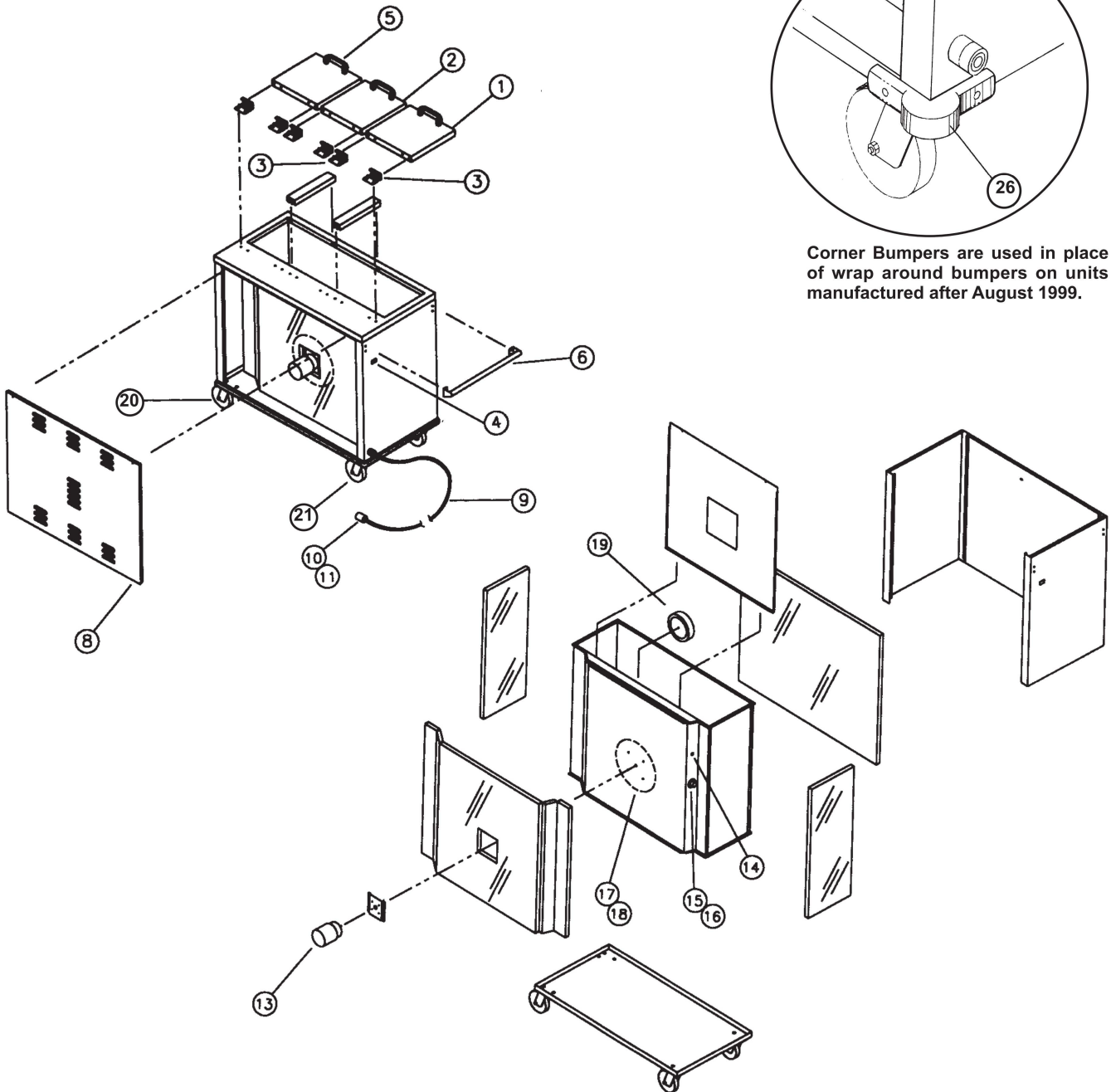

Corner Bumpers are used in place of wrap around bumpers on units manufactured after August 1999.

ELEVATOR ASSEMBLY EXPLODED VIEW DRAWING

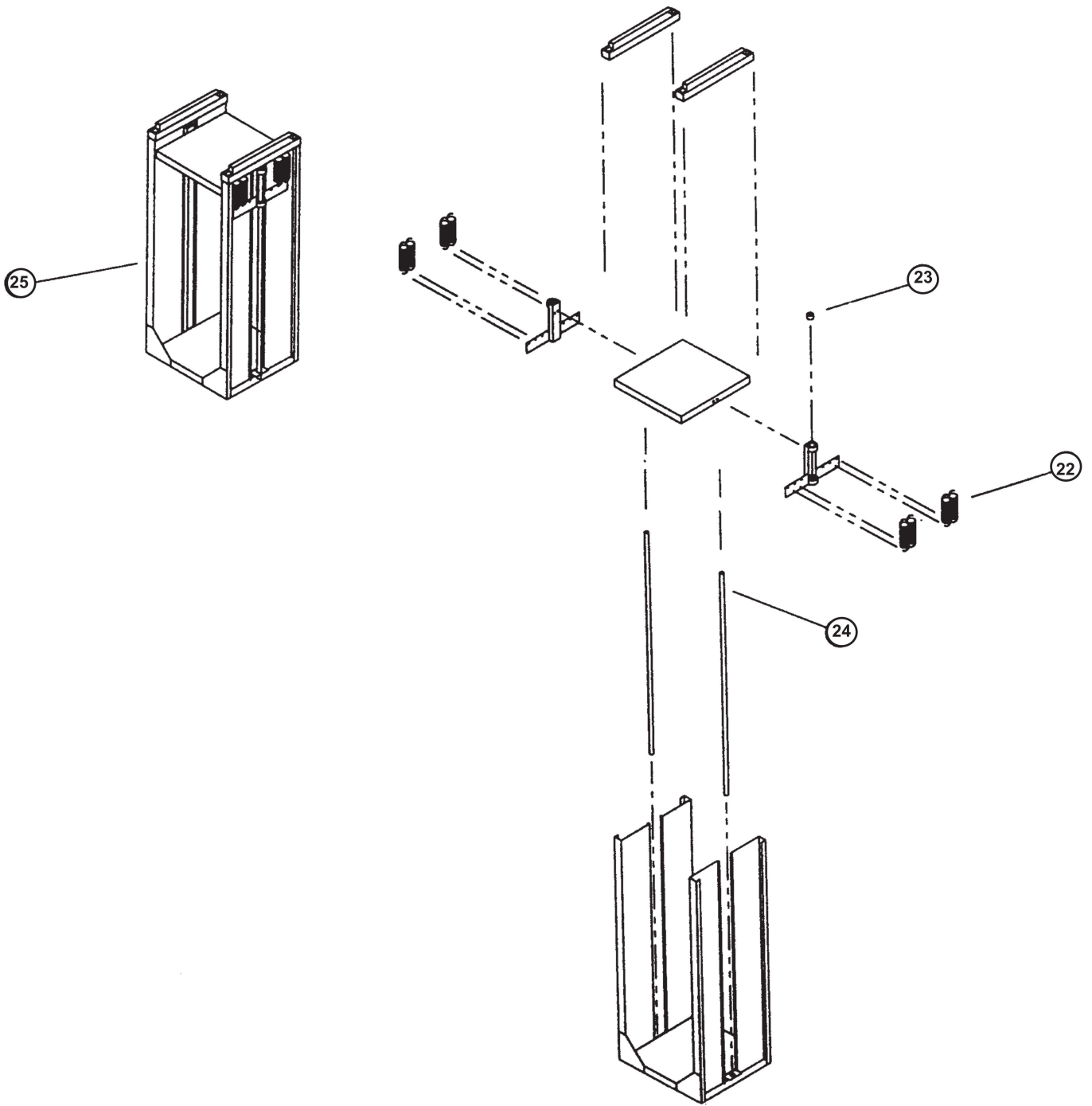

X. SERVICE

In the event service is required on your Aladdin DH07 / DH08 Series Plate Heaters please call:

ALADDIN TEMP-RITE SERVICE DEPARTMENT 1-800-888-5426

XI. WARRANTY

ALADDIN TEMP-RITE®
EQUIPMENT
LIMITED WARRANTY

Effective August 1, 2005

Aladdin Temp-Rite® ("ATR") warrants to the original purchaser that the equipment listed below shall be free from defects in material and workmanship under normal use for the applicable warranty term set forth below. ATR's obligation under this warranty is limited to the repair or replacement, at the sole option of ATR, of any part which upon inspection and examination by ATR or its authorized agent is found to be defective. A written description detailing the nature of the claimed defect, together with the equipment claimed to be defective if required by ATR, must be delivered to ATR or its authorized agent within 30 days of discovery of the claimed defect (but in no event later than 30 days after the expiration of the applicable warranty term).

EQUIPMENT	WARRANTY TERM	
	PARTS	LABOR
DH07	1 Year	90 Days
DH08	1 Year	90 Days

*The warranty term commences 30 days after the date of ATR's invoice for the equipment.

THE WARRANTIES AND REPRESENTATIONS OF ATR CONTAINED HEREIN ARE EXPRESSLY IN LIEU OF, AND THE BUYER WAIVES, ANY AND ALL OTHER WARRANTIES EXPRESS OR IMPLIED, INCLUDING THE WARRANTIES OF MERCHANTABILITY AND FITNESS FOR A PARTICULAR PURPOSE, AND ANY OTHER REMEDIES AGAINST ATR, WHETHER BASED UPON CONTRACT, NEGLIGENCE, STRICT LIABILITY OR OTHERWISE. ATR SHALL NOT BE LIABLE FOR ANY CONSEQUENTIAL OR INCIDENTAL DAMAGES OR ECONOMIC LOSS OF ANY NATURE (INCLUDING WITHOUT LIMITATION LOSS OF REVENUES AND/OR PROFITS) THAT MAY BE CLAIMED TO RESULT FROM ANY NEGLIGENCE OR BREACH OF WARRANTY OR CONTRACT BY ATR.

Exceptions and Exclusions

This warranty is issued only to the original purchaser, and is not transferable and applies only to the products installed within the United States of America, its territories and Canada. During the term of any labor warranty, ATR will pay all pre-approved shipping charges incurred in returning defective equipment to ATR and labor costs incurred in the removal and reinstallation of such equipment. Contact ATR before returning any defective equipment or otherwise performing any warranty repairs. ATR assumes no liability for any work or repair performed without its prior approval. After the expiration of any labor warranty, the original purchaser is responsible for all shipping charges incurred in returning defective equipment to ATR and labor for removing and reinstalling such equipment. ATR shall not be responsible for the replacement of expendable items like lamps and fuses or product failure resulting from normal wear and tear, improper installation, misuse, sabotage, abuse, neglect, accident, unauthorized alterations to repair, or other factors beyond the control of ATR. Neither this warranty, nor the liability of ATR may be modified or extended by action of any agent, distributor or other person or by custom or practice.

CALL ATR TOLL FREE AT 1-800-888-5426 IF YOU HAVE ANY QUESTIONS ABOUT THIS WARRANTY OR YOUR ATR PRODUCT.



250 East Main Street, Hendersonville, TN 37075

1-800-888-8018 • www.aladdintemprite.com • info@aladdin-atr.com