



**INSTALLATION  
AND  
OPERATING  
INSTRUCTIONS**

**Model: M Series  
DIAGONAL CONTACT CONVEYOR TOASTER**

**Model: AT / BT Series  
HORIZONTAL RADIANT CONVEYOR TOASTER**

**INTENDED FOR OTHER THAN HOUSEHOLD USE**

**RETAIN THIS MANUAL FOR FUTURE REFERENCE  
UNIT MUST BE KEPT CLEAR OF COMBUSTIBLES AT ALL TIMES**



**WARNING:** Improper installation, adjustment, alteration, service or maintenance can cause property damage, injury or death. Read the Installation, Operating and Maintenance Instructions thoroughly before installing or servicing this equipment.



This equipment has been engineered to provide you with year-round dependable service when used according to the instructions in this manual and standard commercial kitchen practices.



Phone: +1 (214) 421-7366  
Fax: +1 (214) 565-0976  
Toll Free: +1 (800) 527-2100  
Website: [www.apwwyott.com](http://www.apwwyott.com)  
E-mail: [info@apwwyott.com](mailto:info@apwwyott.com)



P/N 57212 5/12

**APW WYOTT**  
729 Third Avenue  
Dallas, TX 75226

# TABLE OF CONTENTS

<b>GENERAL INFORMATION AND TROUBLESHOOTING</b> .....	2
<b>M SERIES - DIAGONAL CONTACT CONVEYOR TOASTERS</b> .....	3-9
Electrical Specifications .....	3
Installation .....	3
Location .....	6
Operating Instructions .....	6
Field Adjustments & Cleaning .....	7
Troubleshooting Guide .....	9
<b>AT SERIES - HORIZONTAL RADIANT CONVEYOR TOASTERS</b> .....	10-13
Electrical Specifications .....	10
Installation .....	11
Convertible Instructions .....	12
Operating Instructions .....	13
<b>BT-15 SERIES</b> .....	14-16
Electrical Specifications .....	14
Installation .....	14
Operating Instructions .....	15
<b>WARRANTY INFORMATION</b> .....	19

 **WARNING:** In Europe, appliance must be connected by an earthing cable to all other units in the complete installation and thence to an independent earth connection in compliance with EN 60335-1 and/or local codes 

 **WARNING:** An earthing cable must connect the appliance to all other units in the complete installation and from there to an independent earth connection. 

## GENERAL INFORMATION

### General Installation:

1. Always clean equipment thoroughly before first use. (See general cleaning instructions).
2. Check rating label for your model designation & electrical rating.
3. Locate equipment on level counter and plug into a grounded outlet so that the plug is accessible. (See individual description for electrical loads).
4. On units bearing the CE marking, the appliance must be connected by an earthing cable to all other units in the complete installation and then to an independent earth connection.

## GENERAL TROUBLESHOOTING

### Always ask & check:

1. Is the unit plugged in?
2. Check circuit breaker.
3. Is power switch on and pilot light glowing?
4. Check rating label. Are you operating unit on proper voltage?
5. If the supply cord is damaged it should be replaced by an identical supply cord.

If the above checks out and you still have problems, call an APW Wyott authorized service agency.

# M-83, M-83-D & M-91 & M-95

## SPECIFICATIONS:

PLEASE READ PAGE 2 - "GENERAL INFORMATION", BEFORE YOU CONTINUE.

### Electrical Information - All Models

Each unit is equipped with a 4 foot (122cm), 3 wire grounded power supply cord which terminates with a 3 prong plug. The 120V units have a NEMA 5-15P plug. The 208/240V units have a NEMA 6-20 plug.

**NOTE:** Units rated 120V for installation in Canada have a NEMA 5-20P plug.

Model Number	Stock Number	Dimensions*	Electrical	Productivity Halves/Hour	Weight Net/Ship
M-83	83501		120V-1600W-13.3A	Up to 1600	
	83502	20"H x 24 5/8"W x 12"D	208V-1600W-7.7A	" "	83/93 lbs
	83504	50.8 cm x 62.6 cm x 30.5 cm	230V-1470W-6.4A-50Hz 240V-1600W-6.7A	" "	37.7/42.2 kg
M-830	84578		120V-1600W-13.3A	Up to 1600	
	84579	20"H x 24 5/8"W x 12"D	208V-1600W-7.7A	" "	83/93 lbs
	84590	50.8 cm x 62.6 cm x 30.5 cm	230V-1470W-6.4A-50Hz 240V-1600W-6.7A	" "	37.7/42.2 kg
M-95-2	M952AA001		120V-1800W-15A		681lbs.
	M952CA001	30 1/2"H x 21 1/2"W x 17 1/2"D	208V-2780W-13.4A		30.9 kg
	M952EA001	77.5 cm x 54.7 cm x 44.5 cm	230V-2550W-11.1 A-50Hz 240V-2780W-11.6A		
M-95-3	M953AA001		120V-1800W-15A		77lbs.
	M953CA001	30 1/2"H x 24 1/2"W x 17 1/2"D	208V-2780W-13.4A		35 kg
	M953EA001	77.5 cm x 62.3 cm x 44.5 cm	230V-2550W, 11.1 A-50Hz 240V-2780W-11.6A		

\*With Superfeeder: M-83 & M-83D - add 11" (28cm) to height, 4 1/2" (11.5cm) to depth.

## INSTALLATION

### 1. UNPACK UNIT

- a) Remove unit from shipping carton, unwrap loose parts and remove any packing tape, plastic wrap and nylon tie-down.
- b) Refer to the illustrations below and account for the following parts:

Part	M-83	M83-D	M-91	M-95
Legs (Item 1)	wrapped, internal package	wrapped, internal package	wrapped, internal package	wrapped, internal package
Butter Roller (Item 2)	plastic wrapped, shipped in place	-	plastic wrapped, shipped in place	-
Butter Pan (Item 3)	plastic wrapped, shipped in place	-	plastic wrapped, shipped in place	-
Conveyor (Item 5)	boxed, external package.	boxed, external package	strapped in place with nylon tie	-
Bun Chute Feeder (Item 7)	shipped in box with Conveyor	shipped in box with Conveyor	wrapped, internal package	wrapped, internal package
Instruction Manual	wrapped, internal package	wrapped, internal package	wrapped, internal package	wrapped, internal package
PTFE Sheet Kit (optional)	wrapped, internal, package	wrapped, internal package	wrapped, internal package	-

**NOTE:** Prior to initial start-up, all removable parts and the grill surface should be cleaned with warm, soapy water to remove manufacturing oils, then rinsed and dried thoroughly. Apply oil to the conveyor chain after washing. Also the grill surface should be seasoned with a light coating of oil (fry oil works well) and pre-heated for 15 - 20 minutes.

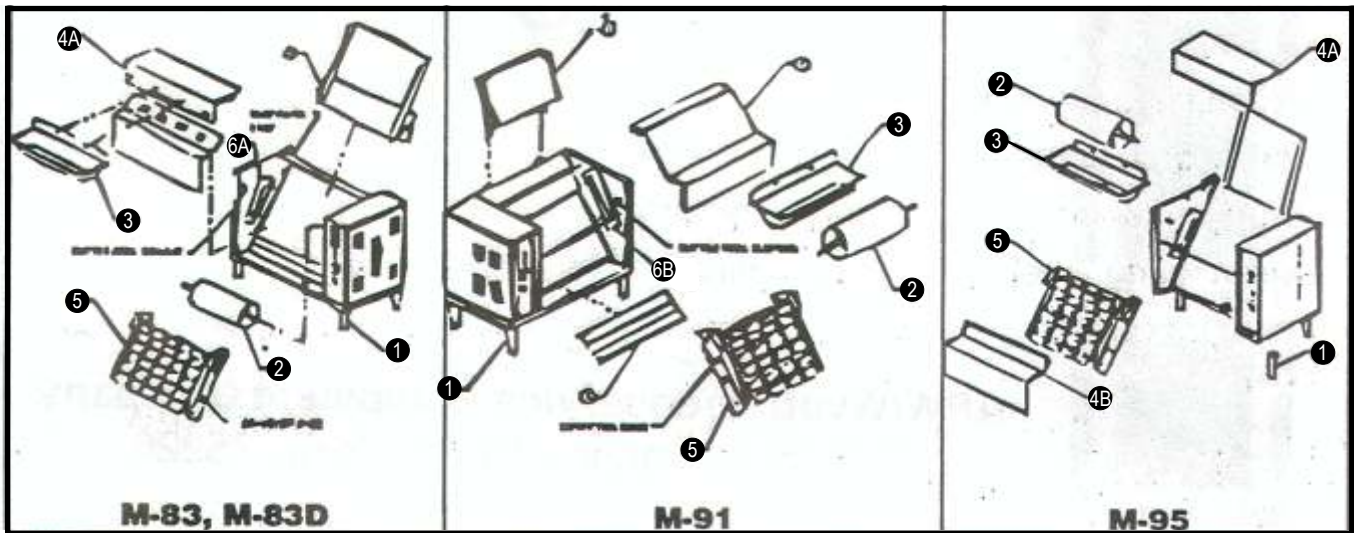

2. ASSEMBLY (REFER TO ILLUSTRATIONS ABOVE)

- a) Lay the toaster on its side and install the four Adjustable Legs (Item 1) in threaded holes in base. Tighten legs with crescent wrench. The unit may be leveled by unscrewing the lower insert of each leg. Precise leveling is not required for proper operation of the toaster. Set the toaster upright.  
**CAUTION: DO NOT OPERATE THE TOASTER WITHOUT THE LEGS INSTALLED.**

3. CONVEYOR INSTALLATION

**M-83 Only:**

Remove Butter Roller (Item 2) by pushing shaft to the left to disengage. Remove Butter Pan (Item 3) by lifting the pan up and off the supporting pins.

**M-83/M-83D:**

- a) Remove Top Front Panel (Item 4A) by gripping the two black knobs while lifting up and slightly back. The Bottom Front Panel (Item 4B) can then be removed by grasping the top edge with one hand and pulling straight back. Hold the bottom with the other hand and lift up and toward the front; then slide panel down and out underneath the Butter Roller bushings.
- b) Grasp Conveyor (Item 5) by the handles. Lower conveyor knobs into right and left Hangar Brackets (Item 6A/B). Gently push forward to engage gears.  
**CAUTION: THE CONVEYOR IS HEAVY. DO NOT DROP INTO POSITION. DROPPING MAY CAUSE DAMAGE TO GEARS.**
- c) Replace Bottom Front Panel (Item 4B), Top Front Panel (Item 4A), Butter Pan (Item :3) and Butter Roller (Item 2)

**M-91 :**

- a) The Conveyor (Item 5) is shipped in place and strapped down with nylon tie. To remove nylon tie, follow steps b, c and d.
- b) Remove Butter Roller (Item 2) by pushing shaft to the right to disengage. Remove Butter Pan (Item 3) by sliding toward the front of the unit, underneath the Butter Roller Bushings.
- c) Remove Front Panel (Item 4) by gripping the top edge with one hand and the bottom edge with the other hand. Lift up to disengage slots in panel from retaining rods, then move forward and slide down and out underneath the Butter Roller Bushings.
- d) Cut and remove the nylon tie securing the conveyor. (Note: To remove for cleaning, see "Disassembly" Instructions.)
- e) Replace Front Panel (Item 4), Butter Pan (Item 3) and Butter Roller (Item 2).

**M-95**

- a) The Conveyor (Item 5) is shipped in place and strapped down with nylon tie. To remove nylon tie, follow steps b, c, and d.
- b) Remove Butter Roller (Item 2) by lifting left side of butter roller shaft. Remove Butter Pan by sliding toward the front of the unit, underneath the butter roller bushings.

- c) Remove Top Front Panel (Item 4A) by gripping rear edge and lifting up. The Bottom Front Panel (Item 4B) can then be removed by holding the top edge with one hand and the bottom edge with the other hand, then lifting panel up.
- d) Cut and remove the nylon tie securing the conveyor. (Note: to remove for cleaning, see "Disassembly" instructions.)
- e) Replace Bottom and Top Front Panels (Items 4A & 4B), Butter Pan (Item 3) and Butter Roller (Item 2).

4. BUN CHUTE/FEEDER/SUPER FEEDER INSTALLATION

**M-83/M-83D:** Install Bun Chute/Feeder (Item 7) by fitting slots on each side onto back panel studs located at top rear of unit.

**M-91:** Install Feeder/Super Feeder (Item 7) by sliding feeder support "legs" into channels located at top rear of unit.

5. INSTALLATION OF OPTIONAL PTFE SHEET FOR DRY OPERATION AND/OR INCREASED EASE OF CLEANING

**NOTE:** Apply light coating of oil to grill surface prior to installation of PTFE sheet.

**M-83 & M-91**

- a) Lay PTFE Sheet on flat surface. Measure approximately 2" from end of sheet. Notch corners as needed. Fold under 2" long flap. Crease PTFE Sheet at 2" fold.
- b) Remove Super Feeder (bun chute). From rear of PTFE Sheet retainer bracket, slip 2" fold of PTFE Sheet under bracket. Bring balance of sheet forward and smooth sheet down against grill plate.
- c) Reinstall Super Feeder bun chute.

**M-95**

- a) Slide one' end of PTFE sheet beneath conveyor to bottom of grill plate.
- b) Place other end of PTFE sheet over top edge of grill plate.
- c) Install PTFE sheet retainer over PTFE sheet and grill plate.

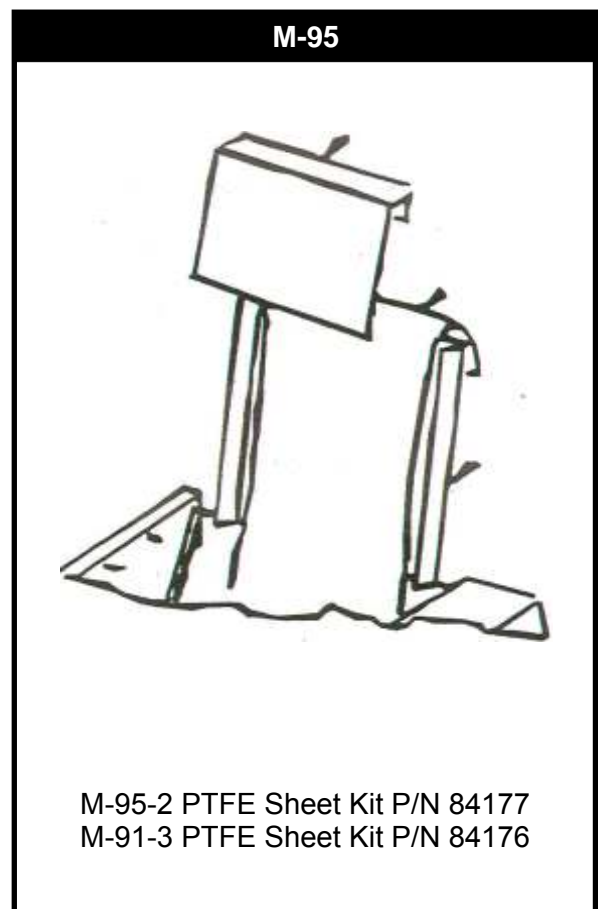
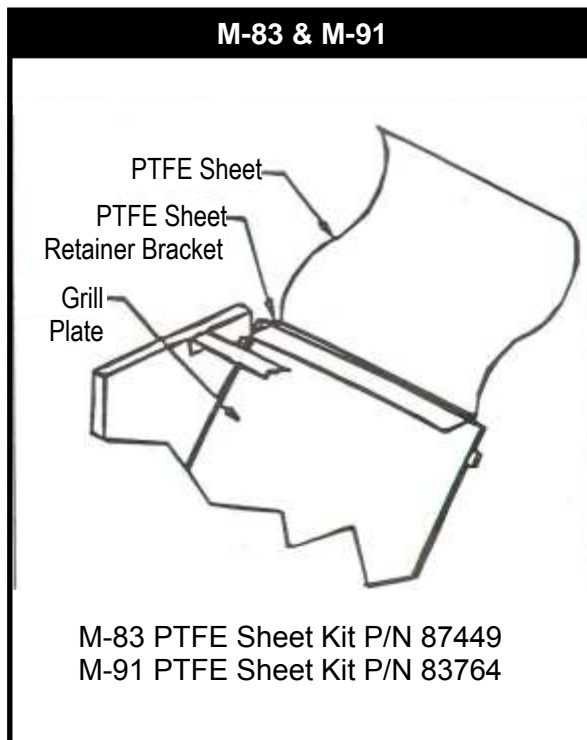

## LOCATION

1. Place the toaster on a flat surface and in such a way that the unit's vents are not blocked. Air must circulate under and through the vents provided on the base, right side (M-83, M83D, & M-95), left side (M-91) and rear of the unit.
2. Locate the unit near a wall receptacle of the proper configuration. **DO NOT USE AN EXTENSION CORD.** Plug the power supply cord into an outlet (receptacle) of the voltage specified on the unit's rating plate. Outlets must be properly grounded.

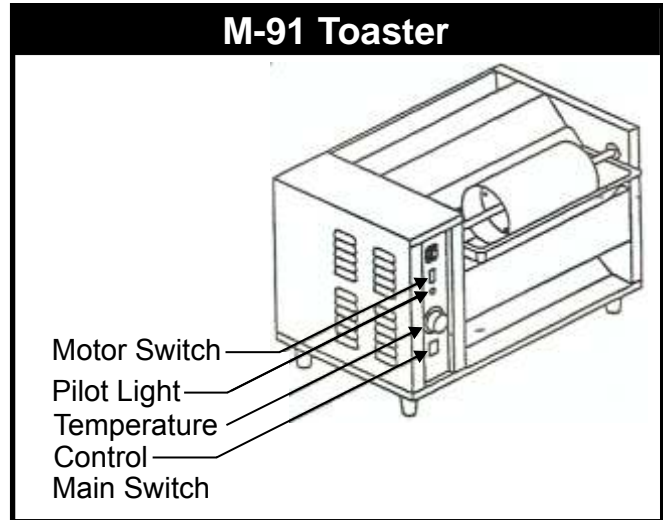
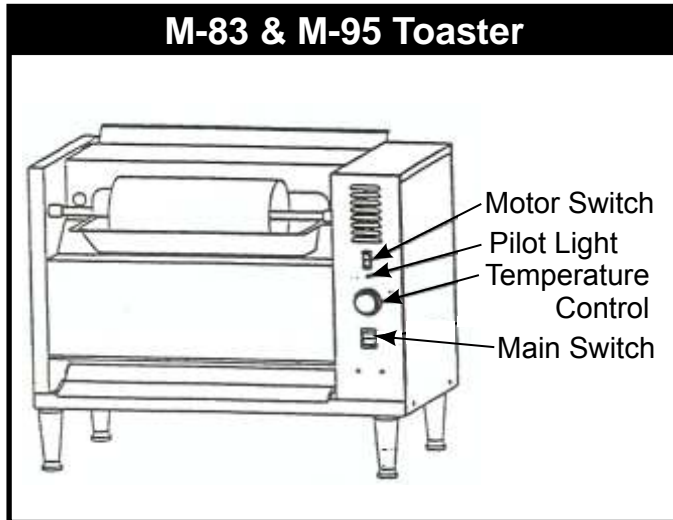

## M-83 & M-91 OPERATING INSTRUCTIONS

### A. PREPARATION

1. Warm-up Time: Turn the control knob to 400°F (number 8) or 450°F (number 9) using optional PTFE Sheet. Wait 15-25 minutes or until the pilot light cycles on and off twice.
2. Use of Oil: Any high-quality oil may be used in the Bun Grill Toaster. While health concerns have led to the decreased use of tropical cooking oils, coconut oil does caramelize when toasted to give the product an appetizing golden color. It also helps the product to reach and maintain the optimum serving temperature. Whereas some cooking oils tend to gum up, those designed for use in toasters will work throughout the day without the need to stop and clean the grill.

### B. CONTROL PANEL

The face of the panel has two (2) lighted rocker switches and a temperature control:

1. **Main Switch** - main power **On/off**.
2. **Motor Switch** - **On/off** switch turns both butter roller and conveyor on and off.
3. **Temperature Control** - Controls the temperature of the grill. The pilot light will stay on until the grill temperature has been attained and will then turn off. Allow the pilot light to cycle twice so the unit is at stabilized temperature for toasting buns.  
**NOTE:** During slow periods to conserve energy and prolong motor life, you may turn temperature control down to 150°F (66°C) and turn off motor switch.
4. **Pilot Light** - Glows when grill is on.

## C. PRODUCTION

**To Grill Buns** - the following is the basic procedure to operate the bun toaster.

**Fig. 1.** Heat toaster oil to melting point and fill the butter roller tray 2/3 full.

**Fig. 2.** Turn "Main" power switch to "on." Turn motor switch "on"; the butter roller and conveyor will start. The oil should spread evenly over the butter roller cylinder.

**Fig. 3.** Now... hold a bun half in the palm of the hand and in one motion (1) slap the sliced surface of the bun on the butter roller, and (2) drop the bun, sliced surface toward the grill, into the top of the unit. The bun half will drop out in the front at the bottom of the unit.

**Fig. 4.** The resulting toasted bun should be (a) hot to the touch, (b) soft and fresh and (c) a golden brown color over the entire surface. If the toast is slightly warm, dry and pale colored, this indicates that the oil has been improperly applied. Try several buns for practice.

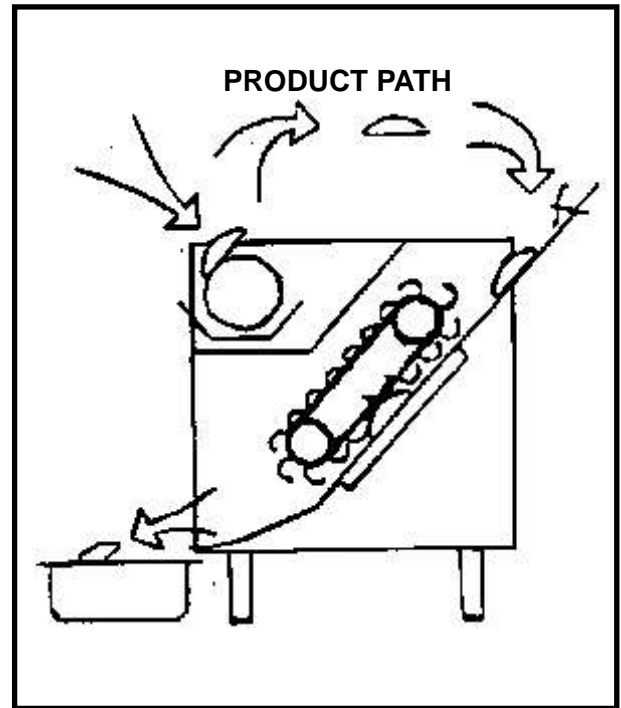

**PRODUCT INTERIOR TEMPERATURE:** The interior temperature of the bun will be in the range of 150°F - 160°F (66°C - 71°C) depending upon the amount of oil and grill temperature setting of the control.

**Fig. 5.** If you want a lighter or darker color to the bun, decrease or increase the temperature setting.

**Fig. 6. NOTE:** Should you change the setting, please allow two (2) cycles for the grill plate to adjust to the new setting. Once you have settled on a bun color, note the setting and keep it there. To turn unit off, just use main switch.

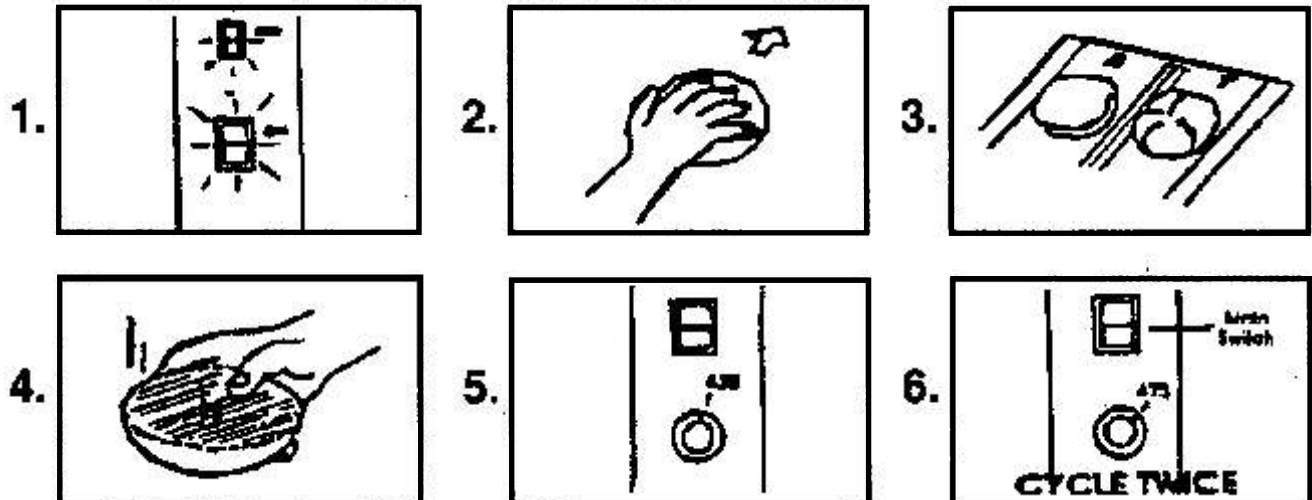

## FIELD ADJUSTMENTS & CLEANING

### A. DISASSEMBLY (REFER TO ILLUSTRATIONS ON PAGE 2.)

1. Turn main power switch "off." - Remove power supply plug from wall receptacle.
2. Remove Butter Roller (Item 2).

**M-3 & M-83D Only:** Push Butter Roller shaft to the left to disengage the notched end of the shaft from the drive motor and remove. To facilitate cleaning, the shaft assembly may be separated from the Butter Roller cylinder. Hold cylinder securely with one hand and slide the shaft out with the other hand.

**M-91:** Push Butter Roller shaft to the right to disengage the notched end of the shaft from the drive motor and remove. To facilitate cleaning, the shaft assembly may be separated from the Butter Roller cylinder. Hold cylinder securely with one hand and slide the shaft out with the other hand.

**M-95:** Lift left side of butter roller shaft out of "cradle" and remove. To facilitate cleaning, the shaft assembly may be separated from the Butter Roller cylinder. Hold cylinder securely with one hand and slide the shaft out with the other hand.

3. Remove Butter Pan (Item 3).

**M-3:** Lift the Butter Pan up and off the supporting pins.

**M-91 & M-95:** Slide Butter Pan toward the front of the unit and beneath the Butter Roller bushings.

4. Remove Front Panel(s) (Item 4).

**M-3:** Remove the Top Front Panel (Item 4A) first by gripping the "two black knobs and lifting up and slightly back. The Bottom Front Panel (Item 4B) can then be removed by holding the top edge with one hand and pulling straight back. Next, hold the bottom edge with the other hand and lift up and toward the front; then slide panel down and out between the Butter Roller bushings.

**M-93:** To remove the Front Panel (Item 4) grasp the top edge with one hand and the bottom edge with the other hand. Lift up to disengage slots in panel, then move forward and slide down and out underneath the Butter Roller bushings: "

**M-95:** To remove the Top Front Panel (Item 4A) grip rear edge and lift up. The Bottom Front Panel (Item 4B) can then be removed by holding the top edge with one hand and the bottom edge with the other hand, then lifting panel up.

5. Remove Conveyor (Item 5).

Grasp Conveyor by the handles on each side and pull toward the front of the unit to disengage gears. Gear engagement may be tight; if so, push the conveyor chain weights slightly to rotate conveyor. Then lift Conveyor up and off the left and right Hanger Brackets. CAUTION: THE CONVEYOR IS HEAVY. HOLD TIGHTLY.

6. Remove Bun Chute/Feeder/Super Feeder (Item 7). (M-83 & M-91 Only.)

**M-83:** Lift Bun Chute or Feeder up and off the back panel studs located at top rear of unit on left and right sides.

**M-91:** Remove the Feeder/Super Feeder by gripping the sides and lifting up so that "support "legs" slide out of the channels at rear of unit. "

7. **M-83 Only** - To remove the Bottom Rear Back Panel (not shown in illustration), face the rear of the unit, grip the two black knobs, and lift up and off the left and right support pins.

8. **M-91 Only** - Remove lower Front Bun Slide (Item 8) by lifting up and off the support studs and pulling forward.

#### B. FIELD ADJUSTMENT OF GRILL PRESSURE:

Bun grilling is a function of THREE FACTORS: Speed, Temperature and Pressure. If speed and temperature have been adjusted (see page 4), and optimum browning has not been achieved, adjust the conveyor hanging brackets (Item 6A1B). loosen left and right brackets. Move them equally toward the grill plate in 1/8" (.32 cm) increments and re-tighten screws. Adjust gear engagement as needed with hanger plate bolts and lock nuts. CAUTION: Make sure grill plate is cool.

#### C. CLEANING:

1. All of the parts removed from the unit may be placed in a dishwasher or sink for washing with your usual detergent and hot water. Use a grill screen or plastic abrasive pad (Scotch Brite pads are recommended) to remove stubborn baked-on oil from grill plate surface. DO NOT use steel wool. Rinse thoroughly and dry. Oil chains after washing (apply toaster oil).
2. Grill Plate-Scour grill plate completely, rinse and dry thoroughly. Then coat with a light film of toaster oil. (For baked-on oil use grill screen or Scotch-Brite pad).
3. Reassemble.



## CONTACT TOASTER TROUBLESHOOTING GUIDE

PROBLEM	CAUSE	SOLUTION
Buns won't toast....	<ul style="list-style-type: none"> <li>a. Wrong temperature setting.</li> <li>b. Wrong oil is used.</li> <li>c. Improper application of oil.</li> <li>d. Excessive cupping of bread surface.</li> </ul>	<ul style="list-style-type: none"> <li>a. Set Thermostat at 4000 or number 8 and allow a full 20 minutes for warm-up.</li> <li>b. Coconut oil is the recommended oil. Use of other oils will prove to be unsatisfactory.</li> <li>c. Sun surface should have even application of oil.</li> <li>d. Use fresher bread. Get better cutting from baker.</li> </ul>
Buns toast unevenly. . . .	<ul style="list-style-type: none"> <li>a. Only part of bun surface is toasted - other part is pale in color and dry.</li> <li>b. Excessive cupping of bread surface.</li> <li>c. Not enough pressure.</li> </ul>	<ul style="list-style-type: none"> <li>a. Improper application of oil - brush bun over butter roll so as to provide bun surface with even coating of oil.</li> <li>b. Use fresher bread. Get better cutting from baker.</li> <li>c. Adjust conveyor hanging brackets.</li> </ul>
Buns stick to grill. . . . .	<ul style="list-style-type: none"> <li>a. Wrong oil is used.</li> <li>b. Grill surface has baked-on oil residue.</li> <li>c. Doughy buns or excess sugar and moisture plus overheated grill may cause sticking.</li> <li>d. Bun weights on conveyor chain assembly are too slick and slide off the bun.</li> <li>e. Buns not defrosted</li> <li>f. For c, d, and e above.</li> </ul>	<ul style="list-style-type: none"> <li>a. Review Operation Information, Paragraph A, "Use of Oil"</li> <li>b. Clean grill surface. Use Chore-Girl Pads to cut through residue. Daily cleaning will prevent residue build-up</li> <li>c. Set temperature to 4100 or number 8 and, perhaps, use day-old buns or try another bun source.</li> <li>d. Use sandpaper to roughen the surface of the weight.</li> <li>e. Defrost buns.</li> <li>f. Use PTFE sheet.</li> </ul>
Unit Dead - No power. .	<ul style="list-style-type: none"> <li>a. No power at wall receptacle.</li> <li>b. Plug disconnected.</li> <li>c. Relay (M-83).</li> <li>d. Main Switch.</li> <li>e. Circuit Breaker.</li> </ul>	<ul style="list-style-type: none"> <li>a. Check fuse of breaker panel.</li> <li>b. Check plug.</li> <li>c. Check the relay output (M-83),</li> <li>d. Check that switch is on and operative.</li> <li>e. Check and reset.</li> </ul>
Grill won't heat. . . . .	<p>.....and conveyor and butter roller are OKAY</p> <ul style="list-style-type: none"> <li>a. Loose power cord connections.</li> <li>b. Loose control connections.</li> <li>c. Faulty thermostat</li> <li>d. Burnt out element.</li> </ul>	<ul style="list-style-type: none"> <li>a. Check power cord connection in control panel.</li> <li>b. Check control.</li> <li>c. Replace thermostat.</li> <li>d. Replace element.</li> </ul>
Conveyor and Butter Roller Inoperative. . . . .	<p>.....and grill OKAY</p> <ul style="list-style-type: none"> <li>a. Loose connections to switch.</li> <li>b. Switch burned out.</li> <li>c. Motors defective.</li> </ul>	<ul style="list-style-type: none"> <li>a. Check switch for loose or broken connections.</li> <li>b. Replace switch.</li> <li>c. Replace motors.</li> </ul>
Butter Roller won't turn .	<p>.....and butter roller motor OKAY</p> <ul style="list-style-type: none"> <li>a. Notched end of butter roll shaft not engaged with motor drive.</li> <li>b. -or wrong end of shaft inserted in spring loaded socket.</li> </ul>	<ul style="list-style-type: none"> <li>a. Realign butter roll shaft to engage with drive.</li> <li>b. Reverse butter roll and shaft assembly notched end toward motor drive.</li> </ul>
Conveyor won't move. . .	<p>.....and conveyor motor OKAY .....and butter roller OKAY</p> <ul style="list-style-type: none"> <li>a. Drive gears not engaged.</li> <li>b. Bun weights are binding.</li> <li>c. Linkage is binding - and conveyor drive motor won't turn.</li> </ul>	<ul style="list-style-type: none"> <li>a. Remove conveyor and re-install to make sure drive gears engaged properly.</li> <li>b. Check weights for clearance between each one.</li> <li>c. Check conveyor linkage for bent links.</li> </ul>
Conveyor won't move. . .	<ul style="list-style-type: none"> <li>a. Loose connection between switch and conveyor motor.</li> <li>b. Conveyor motor burnt out.</li> </ul>	<ul style="list-style-type: none"> <li>a. Check circuit switch to conveyor motor for loose or broken connection.</li> <li>b. Replace motor.</li> </ul>

# AT-10, AT-30, AT-10BT, AT-5, AT-200

## SPECIFICATIONS

PLEASE READ PAGE 2 - "GENERAL INFORMATION," BEFORE YOU CONTINUE.

### Electrical Information - Models AT-10 & AT-30:

Each unit is equipped with a 4 foot (122 cm), 3 wire grounded power cord which terminates with a standard 3 prong plug. The 120V units have a 5-15P plug. The 208/240V units have a 6-20P plug.

MODEL NUMBER	AT-10	AT-30
Overall Dimensions with Superfeeder	1 1/2" (3.8 cm) Product Opening 14"H x 15 5/16"W x 21 5/8"D (35.6 cm x 38.9 cm x 55 cm)  3" (7.6 cm) Product Opening: 15 1/2"H x 15 5/16"W x 21 5/8"D (39.4 cm x 38.9 cm x 55 cm)	1 1/2" (3.8 cm) Product Opening: 14"H x 18 5/16"W x 21 5/8"D (35.6 cm x 46.6 cm x 55 cm)  3" (7.6 cm) Product Opening: 15 1/2"H x 18 5/16"W x 21 5/8"D (39.4 cm x 46.6 cm x 55 cm)
Stock Number/Electrical	1 1/2" (3.8 cm) Product Opening: 120V-1760W-14.7 amps 208V-2840W-13.7 amps 230V-2610W-11.4 amps-50 Hz 240V-2840W-11.9 amps  3" (7.6 cm) Product Opening: 120V-1760-14.7 amps 208V-2840W-13.7 amps 230V-2610W-11.4 amps-50 Hz 240V-2840W-11.9 amps	1 1/2" (3.8 cm) Product Opening:  208V-3340W-16.1 amps 230V-3070W-13.4 amps-50 Hz 240V-3340W-14.0 amps  3" (7.6 cm) Product Opening:  208V-3340W-16.1 amps 230V-3070W-13.4 amps-50 Hz 240V-3340W-14.0 amps
Productivity (Fresh Product) Bun Halves per hour Bread/toast sliced per hour Bagel Halves per hour English muffins per hour	(120V)-355 (208V/240V)-533 (120V)-483 (208V/240V)-724 (120V)-405 (208V/240V)-608 (120V)-213 (208V/240V)-405	(208V /240V)-800 (208V/240V)-1086 (208V/240V)-912 (208V /240V)-608
Net/Shipping Weight	39 Lbs./45 Lbs. (17.7/20.5 kg)	45 Lbs./52 Lbs. (20.5/23.6 kg)

### Electrical information - AT-10BT & AT-5

Each toaster is equipped with a 4 foot (122 cm), 3 wire grounded power supply cord which terminates with a 3 prong plug (5-15P).

MODEL NUMBER	AT-10BT	AT-5
Overall Dimensions with Superfeeder	14"H X 15 5/16"W x 21 5/8"D (35.6. cm x 38.9 cm x 55 cm)	14"H X 15 5/16"W x 21 5/8"D (35.6 cm x 38.9 cm x 55 cm)
Stock Number/Electrical	120V-1760W-14.7 amps	120V-1440W-12.0 amps
Productivity (Fresh Product) Bun Halves per hour Bread/toast sliced per hour	(120V) - 600	
Net/Shipping Weight	39 Lbs./45 Lbs. 17.7/20.5 kg	39 Lbs./45 Lbs. 17.7/20.5 kg

## Electrical information - AT-200

Each toaster is equipped with a 4 foot (122 cm), 3 wire grounded power supply cord which terminates with a 3 prong plug (6-50P).

MODEL NUMBER	AT-200
Overall Dimensions with Superfeeder	18 3/8"H X 15 3/4"W x 26 1/2"D (46.7 cm x 40 cm x 67.4cm)
Stock Number/Electrical	208V-5600W-27.0 amps 230V-5145W-22.4 amps-50 Hz 240V-5600W-23.4 amps
Productivity (Fresh Product) Bun Halves per hour Bread/toast sliced per hour Croissants per hour English muffins per hour	( 208V/240V )-1200 ( 208V/240V )-1400 ( 208V/240V )-1400 ( 208V/240V )-1000
Net/Shipping Weight	68 Lbs./75 Lbs. (30.9/34.1 kg)

## INSTALLATION - AT SERIES

### A. UNPACK UNIT

1. Remove unit from shipping carton, unwrap loose parts and remove any packing tape.
2. Refer to the illustration below and account for the following parts:
  - a) (4) legs - wrapped, internal package
  - b) Bread Slide - shipped in place
  - c) Bread Drawer - shipped in place
  - d) Reflector/Crumb Tray - shipped in place
  - e) Superfeeder (optional) - wrapped, internal package
  - f) Instruction manual -wrapped, internal package

### B. ASSEMBLY

1. Lay the toaster on its side and install four adjustable legs into threaded holes in base. Tighten legs with crescent wrench. The unit may be leveled by unscrewing the lower insert of each leg. Precise leveling is not required for proper operation of the toaster. Set the toaster upright. **CAUTION: DO NOT OPERATE THE TOASTER WITHOUT THE LEGS INSTALLED.**
2. Refer to the illustration and check that the Reflector/Crumb Tray is in the proper position. **CAUTION: DO NOT OPERATE THE TOASTER WITHOUT, THE REFLECTOR/CRUMB TRAY IN POSITION UNDER THE CONVEYOR CHAIN.**
3. Check that the Bread Drawer is positioned flat on toaster base and pushed to the rear until it stops. (Note: Bread Drawer is installed or removed by lifting the front handle at an angle so that the rear edge of drawer slides under the two front internal studs on right and left sides of toaster walls.)
4. Check that the Bread Slide is situated internally so that the "tabs" on each side are resting behind the two rear internal studs on right and left sides of toaster walls. The front edge of the Bread Slide rests on top of the two front internal studs on right and left sides of the toaster walls. The Bread Slide should be covering the rear portion of the bread drawer.
5. Attach the optional Superfeeder on the rod and pins located in front of the conveyor belt as shown in the illustration.

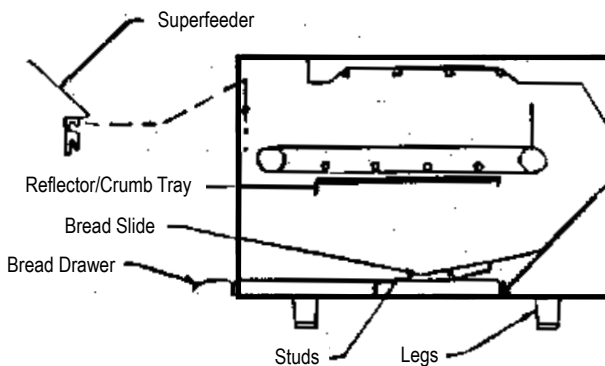

### C. INSTALLATION

1. Place the toaster on a flat surface and in such a way that the unit's vents are not blocked. Air must circulate under and through vent provided on the base, left side and at the rear of the unit. A minimum clearance of one inch (1", 2.6 cm) is required on the base and two inches (2", 5.2 cm) on the left side and rear of unit. Overhead clearance should allow heat to be dispelled adequately.
2. Locate the unit near a wall receptacle of the proper configuration. DO NOT USE AN EXTENSION CORD. Plug the power supply cord into an outlet of the voltage specified on the unit's rating label plate. Outlets must be grounded properly.

## CONVERTIBLE AT SERIES TOASTER

To convert an AT Toaster from front return to rear exit, follow steps indicated in Figures 1 to 3.

**Figure 1:**

1. Turn off unit and let cool.
2. Remove Breadslide through front of unit.
3. Extra line if needed.

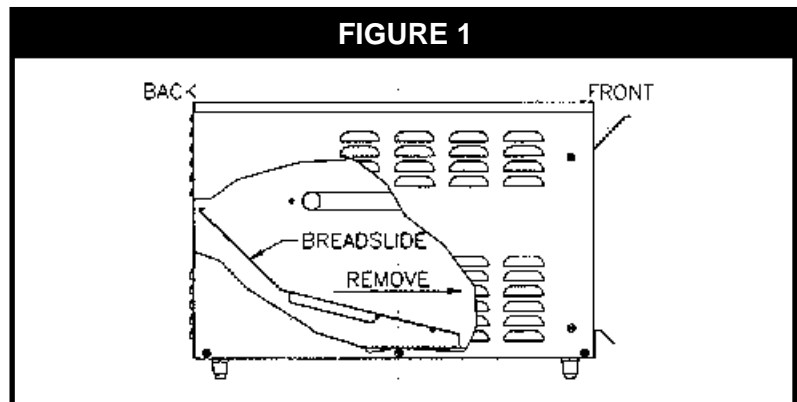

**Figure 2:**

1. Flip Breadslide over.
2. Insert Breadslide through back opening.
3. Place on conveyor belt.

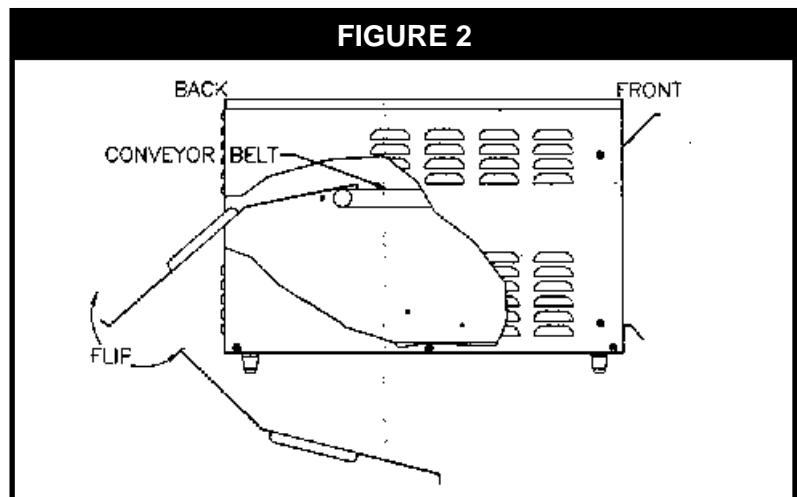

**Figure 3:**

1. Turn on unit.
2. Conveyor belt will move Breadslide to rest on locator pins.
3. Ready to operate in rear exit mode.

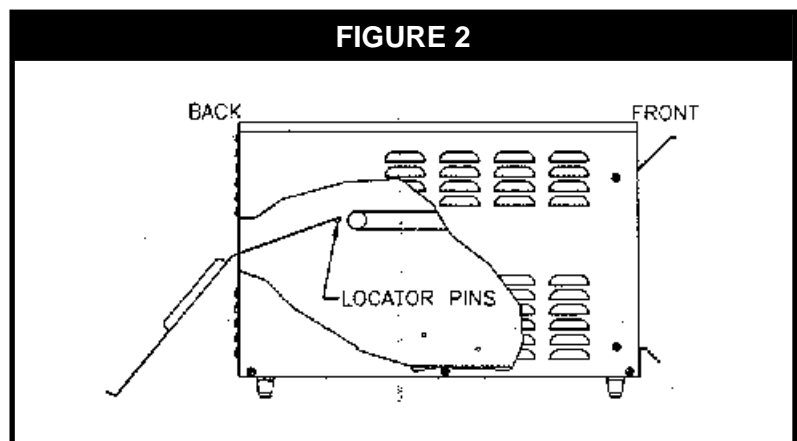

# OPERATING INSTRUCTIONS

## A. PREPARATION/WARM-UP:

1. **Main Power:** Turn toaster on by pressing the **Main Power** switch up. Turn the toaster off by pressing the **Main Power** switch down.
2. **Temperature:** Set the **Top Heat** knob and the **Bottom Heat** knob to the **6** setting (mid range) for warm-up. (Power to the heating elements is off when these knobs are in the off position.) Not available. on AT-5 Model.
3. **Speed:** Set the **Conveyor Speed Knob** to the 5 setting for warm-up.
4. **Stand-By:** Set the **Stand-By** switch to **Full Heat**. Not available on AT-5 Model.
5. **Warm-Up Time:** Warm-up time is approximately 7 minutes.

## B. USE/SPECIAL FEATURES

1. **Product:** Place product on the conveyor. It will automatically be drawn through the toaster at a speed determined by the **Conveyor Speed** setting. Your product may be heated/toasted on one side or both sides depending on where your **temperature control** knobs (top heat & bottom heat) are set.  
**Caution:** *The product is inverted as it is returned to the operator. Therefore, toppings, butter, or icings are not recommended.*  
 Product over 4 1/2" x 1 5/8" (11.5 cm x 4.2 cm) is not recommended
2. **Heating & Toasting Recommendations:** The darkness or lightness of the toasting is determined by the speed and temperature.
  - a) Speed "1" is the slowest setting and will help produce the darkest toast. "9" is the fastest setting and will help produce the lightest toast.
  - b) Temperature: **TOP HEAT** - The **MIN.** setting will help produce the lightest top-toast. **The MAX.** setting will help produce the darkest top toast. Not available on AT-5 Model.  
**BOTTOM HEAT** - The **MIN.** setting will help produce the lightest bottom-toast. The **MAX.** 3, setting will help produce the darkest bottom-toast. **Off** turns the heating elements off.
3. These settings are designed for fresh pre-baked products with an approximate internal temperature of 73°F (23°C). Note: Cooler product requires more heat and/or longer cycle times. Day-old product requires less heat and/or faster cycle times. (Based on 120V unit).

TOASTER CONTROL SETTINGS		Control Settings		
Product	Size	Top Heat	Bottom Heat	Speed
English Muffins	4" Dia. x 1 1/2" (10.2 cm Dia. x 1.3 cm)	Max.	6	4 1/2
Hamburger Buns	4" Dia. x 1" (10.2 cm Dia. x 2.6 cm)	Max.	6	6
Bread Slices	4 1/2" Sq. x 5/8" (11.5 cm Sq. x 1.6 cm)	10	Max.	5 1/2
Butter Crescents	3 1/2" x 2 3/4" x 1 1/4" (8.9 cm x 7 x 3.2 cm)	10	10	5
Brown & Serve Dinner Rolls	2" x 2" X 1 1/2" (5.1 cm x 5.1 cm x 3.9 cm)	10 1/4	10 1/4	5

Toaster temperatures adjust from 100°F (38°C) to approximately 500°F (260°C). The cycle time adjusts from 30 seconds to 3 1/2 minutes for product flexibility. Products will require some experimentation to achieve the appropriate balance of heat control and conveyor speed. Each time the controls are changed, allow about 5 minutes for the temperatures to stabilize.

4. **Stand-By:** Always set Stand-By switch to Full Heat when toasting. When not toasting (or during slack periods), the stand-by position cuts off power to the top heating element and reduces energy consumption by 50% while allowing for faster warm-up than if the toaster were off completely.  
**Remember: The "Stand-By" switch must be in the "Full Heat" position, or the toaster will not toast.**

# BT-15

## SPECIFICATIONS

PLEASE READ PAGE 2 - "GENERAL INFORMATION," BEFORE YOU CONTINUE.

Electrical Information - Models BT-15 .

Each unit is equipped with a 4 foot (122 cm), 3 wire grounded power cord which terminates with a standard 3 prong plug. The 208/240V units have a 6-30P plug.

MODEL NUMBER	BT-15
Overall Dimensions	18 1/2"H x 18 5/16"W x 21 1/4"D (47 cm x 46.6 cm x 54 cm)  Product Opening: 1 5/8" or 2" or 3" (4.2 cm or 5.1 cm or 7.7 cm)
Electrical	208V. 4600 W. 22.2A. 60Hz. 240V. 4600 W. 19.2A. 60Hz. 240V. 4600 W. 19.2A. 50Hz. 230V. 4225 W. 18.4A. 50Hz,
Productivity (Fresh Product results may vary due to mix and moisture content).	Bun Halves per hour (208V/240V) 864 Bread/toast sliced per hour (208V/240V) 576 Bagel Halves per hour (208V/240V) 1440 English muffins per hour (208V/240V) 432
Net/Shipping Weight	58 Lbs./65 Lbs. (26.4kg/29.5kg)

## INSTALLATION - BT SERIES

### A. UNPACK UNIT

1. Remove unit from shipping carton, unwrap loose parts and remove any packing tape.
2. Refer to the illustration below and account for the following parts:
  - a) (4) Legs - wrapped, internal package
  - b) Bread Slide - shipped in place
  - c) Bread Drawer - shipped in place
  - d) Reflector/Crumb Tray - shipped in place
  - e) Superfeeder - wrapped, internal package
  - f) Instruction manual - wrapped, internal package
  - g) Feeder support - wrapped, internal package.

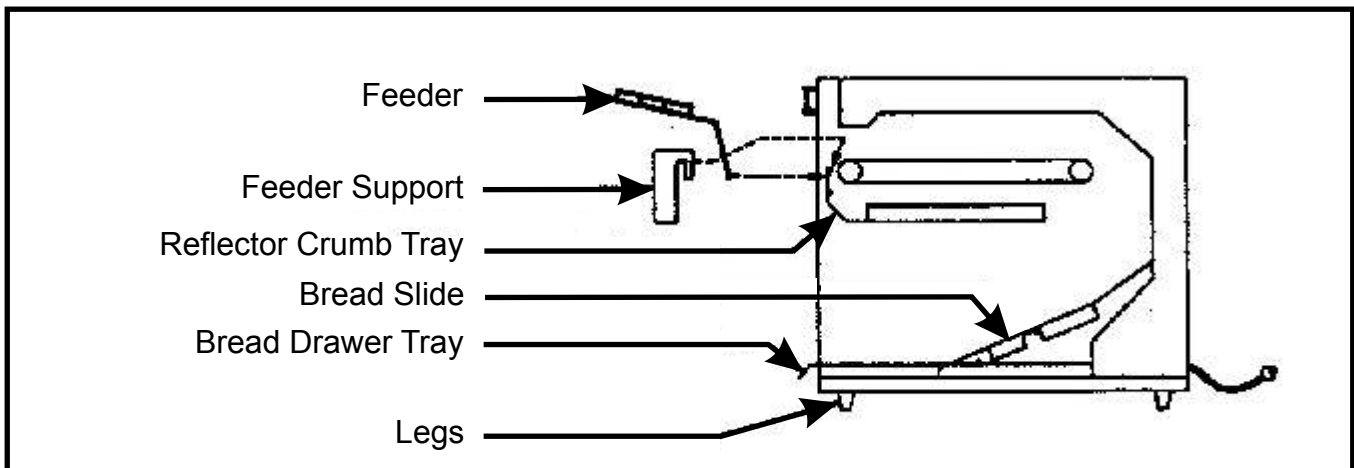

B. ASSEMBLY

1. Lay the toast on its side and install four adjustable legs into threaded holes in base. Tighten legs with crescent wrench. The unit may be leveled by unscrewing the lower insert of each leg. Precise leveling is not required for proper operation of the toaster. Set the toaster upright.  
**CAUTION: DO NOT OPERATE THE TOASTER WITHOUT THE LEGS INSTALLED.**
2. Refer to the illustration and check that the Reflector/Crumb Tray is in the proper position.  
**CAUTION: DO NOT OPERATE THE TOASTER WITHOUT THE REFLECTOR/CRUMB TRAY IN POSITION UNDER THE CONVEYOR CHAIN.**
3. Check that the Bread Drawer is positioned flat on toaster base and pushed to the rear until it stops. (**Note:** Bread Drawer is installed or removed by lifting the front handle at an angle so that the rear edge of drawer slides under the two front internal studs on right and left sides of toaster walls.)
4. Check that the Bread Slide is situated internally so that the "tabs" on each side are resting behind the two rear internal studs on right and left sides of toaster walls. The front edge of the Bread Slide rests on top of the two front internal studs on right and left sides of the toaster walls. The Bread Slide should be covering the rear portion of the bread drawer.
5. Attach the superfeeder on the rod and pins located in front of the conveyor belt as shown in the illustration.

C. INSTALLATION

1. Place the toaster on a flat surface and in such a way that the unit's vents are not blocked. Air must circulate under and through vents provided on the base, left side and at the rear of the unit. A minimum clearance of one inch (1 ") (2.6 cm) is required on the base, both sides and rear of unit. Overhead clearance should allow heat to be dispelled adequately.
2. Locate the unit near a wall receptacle of the proper configuration. **DO NOT USE AN EXTENSION CORD.** Plug the power supply cord into an outlet of the voltage specified on the unit's rating label plate. Outlets must be grounded properly.

## OPERATING INSTRUCTIONS

A. PREPARATION/WARM-UP:

1. Main Power: Turn toaster on by pressing the Main Power switch up. Turn the toaster off by pressing the Main Power switch down.
2. Temperature: Set the Top Heat knob and the Bottom Heat knob to the 6 setting (mid range) for warm-up. (Power to the heating elements is off when these knobs are in the off position.)
3. Speed: Set the Conveyor Speed Knob to the 5 setting for warm-up. 4. Stand-By: Set the Stand-By switch to Full Heat for bagels, muffins and "off" for light density products like bread.
5. Warm-Up Time: Warm-up time is approximately 20 min. for bagels and muffins and 7 min. For buns and bread.

B. USE/SPECIAL FEATURES

1. Product: Place product on the conveyor. It will automatically be drawn through the toaster at a speed determined by the Conveyor Speed setting. Your product may be heated/toasted on one side or both sides depending on where your temperature control knobs (top bottom heat) are set.  
**Caution:** *The product is inverted as it is returned to the operator. Therefore, toppings, butter, or icings are not recommended.*  
Product over 4 1/2" x 1 5/8" (11.5 cm x 4.2 cm) is not recommended.
2. Heating & Toasting Recommendations: The darkness or lightness of the toasting is determined by the speed and temperature.
  - a) Speed 1 is the slowest setting and will help produce the darkest toast. "9" is the fastest setting and will help produce the lightest toast.

- b) Temperature: TOP HEAT - The MIN. setting will help produce the lightest top-toast. The MAX. Setting will help produce the lightest toast.  
 BOTTOM HEAT - The MIN. setting will help produce the lightest bottom-toast. The MAX. setting will help produce the darkest bottom-toast. Off turns the heating elements off.

C. CONTROL SETTINGS

- 1. These settings are designed for fresh pre-baked products with an approximate internal temperature of 73°F (23°C). **Note:** Cooler product requires more heat or longer cycle times. Day-old product requires less heat and/or faster cycle times.

TOASTER CONTROL SETTINGS		CONTROL SETTINGS			
PRODUCT	SIZE	STAND-BY	TOP HEAT	BOTTOM HEAT	SPEED
BAGELS	4 1/2" DIA. x 1" (11.5 cm x 2.6 cm)	ON	8	6	5 3/4
ENGLISH MUFFINS	4" DIA. x 1/2" (10.2 cm x 1.3 cm)	ON	10	3	5
HAMBURGER BUNS	4" DIA. x 1" (10.2 cm x 2.6 cm)	OFF	10	OFF	5
BREAD SLICES	4 1/2" SQ. x 5/8" (11.5 cm. x 1.6 cm)	OFF	5	11	3

- 2. The cycle time adjusts from 11 1/2 to 36 1/2 seconds for product flexibility. Products will require some experimentation to achieve the appropriate balance of heat control and conveyor speed. Each time the controls are changed, allow about 5 minutes for the temperatures to stabilize.
- 3. STAND-BY: Always set stand-by switch to full heat when toasting bagels and english muffins.
  - a) When not toasting bagels or muffins during slow periods turn stand-by switch "off" to reduce energy consumption.
  - b) When not toasting buns and breads (stand-by in off position) during slow periods turn top infinite control "off" to reduce energy consumption.**NOTE:** Be patient all product does not toast the same, with a little. adjusting you can toast properly.

**NOTES**

CONTROL SETTINGS				
PRODUCT	STAND-BY	TOP HEAT	BOTTOM HEAT	SPEED







## APW WYOTT EQUIPMENT LIMITED WARRANTY

APW Wyott Foodservice Equipment Company warrants its equipment against defects in materials and workmanship, subject to the following conditions:

This warranty applies to the original owner only and is not assignable.

Should any product fail to function in its intended manner under normal use within the limits defined in this warranty, at the option of APW Wyott such product will be repaired or replaced by APW Wyott or its Authorized Service Agency. APW Wyott will only be responsible for charges incurred or service performed by its Authorized Service Agencies. The use of other than APW Wyott Authorized Service Agencies will void this warranty and APW Wyott will not be responsible for such work or any charges associated with same. The closest APW Wyott Authorized Service Agent must be used.

This warranty covers products shipped into the 48 contiguous United States, Hawaii, metropolitan areas of Alaska and Canada. There will be no labor coverage for equipment located on any island not connected by roadway to the mainland.

Warranty coverage on products used outside the 48 contiguous United States, Hawaii, and metropolitan areas of Alaska and Canada may vary. Contact the international APW Wyott distributor, dealer, or service agency for details.

### Time Period

One year for parts and one year for labor, effective from the date of purchase by the original owner. The Authorized Service Agency may, at their option, require proof of purchase. Parts replaced under this warranty are warranted for the un-expired portion of the original product warranty only.

### Exceptions

- \***Gas/Electric Cookline:** Models GCB, GCRB, GF, GGM, GGT, CHP-H, EF, EG, EHP. Three (3) Year Warranty on all component parts, except switches and thermostats. (2 additional years on parts only. No labor on second or third year.)
- \***Broiler Briquettes, Rock Grates, Cooking Grates, Burner Shields, Fireboxes:** 90 Day Material Only. No Labor.
- \***Heat Strips:** Models FD, FDL, FDD, FDDL. Two (2) Year Warranty on element only. No labor second year.
- \***Glass Windows, Doors, Seals, Rubber Seals, Light Bulbs:** 90 Day Material Only. No Labor.

In all cases, parts covered by extended warranty will be shipped FOB the factory after the first year.

### Portable Carry In Products

Equipment weighing over 70 pounds or permanently installed will be serviced on-site as per the terms of this warranty. Equipment weighing 70 pounds or under, and which is not permanently installed, i.e. with cord and plug, is considered portable and is subject to the following warranty handling limitations. If portable equipment fails to operate in its intended manner on the first day of connection, or use, at APW Wyott's option or its Authorized Service Agency, it will be serviced on site or replaced.

From day two through the conclusion of this warranty period, portable units must be taken to or sent prepaid to the APW Wyott Authorized Service Agency for in-warranty repairs. No mileage or travel charges are allowed on portable units after the first day of use. If the customer wants on-site service, they may receive same by paying the travel and mileage charges. Exceptions to this rule: (1) countertop warmers and cookers, which are covered under the Enhanced Warranty Program, and (2) toasters or rollergrills which have in store service.

### Exclusions

The following conditions are not covered by warranty:

- \*Equipment failure relating to improper installation, improper utility connection or supply and problems due to ventilation.
- \*Equipment that has not been properly maintained, calibration of controls, adjustments, damage from improper cleaning and water damage to controls.
- \*Equipment that has not been used in an appropriate manner, or has been subject to misuse or misapplication, neglect, abuse, accident, alteration, negligence, damage during transit, delivery or installation, fire, flood, riot or act of god.
- \*Equipment that has the model number or serial number removed or altered.

If the equipment has been changed, altered, modified or repaired by other than an Authorized Service Agency during or after the warranty period, then the manufacturer shall not be liable for any damages to any person or to any property, which may result from the use of the equipment thereafter.

This warranty does not cover services performed at overtime or premium labor rates. Should service be required at times which normally involve overtime or premium labor rates, the owner shall be charged for the difference between normal service rates and such premium rates. APW Wyott does not assume any liability for extended delays in replacing or repairing any items beyond its control.

In all cases, the use of other than APW Wyott Authorized OEM Replacement Parts will void this warranty.

This equipment is intended for commercial use only. Warranty is void if equipment is installed in other than commercial application.

### Water Quality Requirements

Water supply intended for a unit that has in excess of 3.0 grains of hardness per gallon (GPG) must be treated or softened before being used. Water containing over 3.0 GPG will decrease the efficiency and reduce the operation life of the unit.

**Note: Product failure caused by liming or sediment buildup is not covered under warranty.**

**“THE FOREGOING WARRANTY IS IN LIEU OF ANY AND ALL OTHER WARRANTIES EXPRESSED OR IMPLIED INCLUDING ANY IMPLIED WARRANTY OF MERCHANTABILITY OR FITNESS FOR PARTICULAR PURPOSES AND CONSTITUTES THE ENTIRE LIABILITY OF APW WYOTT. IN NO EVENT DOES THE LIMITED WARRANTY EXTEND BEYOND THE TERMS STATED HEREIN.”**

9/05



**24 Hour Toll Free  
Service Hot Line**



**1 (800) 733-2203**

---

Phone: +1 (214) 421-7366  
Fax: +1 (214) 565-0976  
Toll Free: +1 (800) 527-2100  
Website: [www.apwwyott.com](http://www.apwwyott.com)  
E-mail: [info@apwwyott.com](mailto:info@apwwyott.com)

**APW WYOTT**  
729 Third Avenue  
Dallas, TX 75226