

Atlas Metal INDUSTRIES, INC.

Subsidiary of Mercury Aircraft, Inc.

1135 N.W. 159th DR., MIAMI, FL 33169

PHONE (305) 625-2451, (800) 762-7565, FAX (305) 623-0475, E-mail: sales@atlasfoodserv.com

PARTS LIST-PIZZA PREPARATION TABLE PTR SERIES

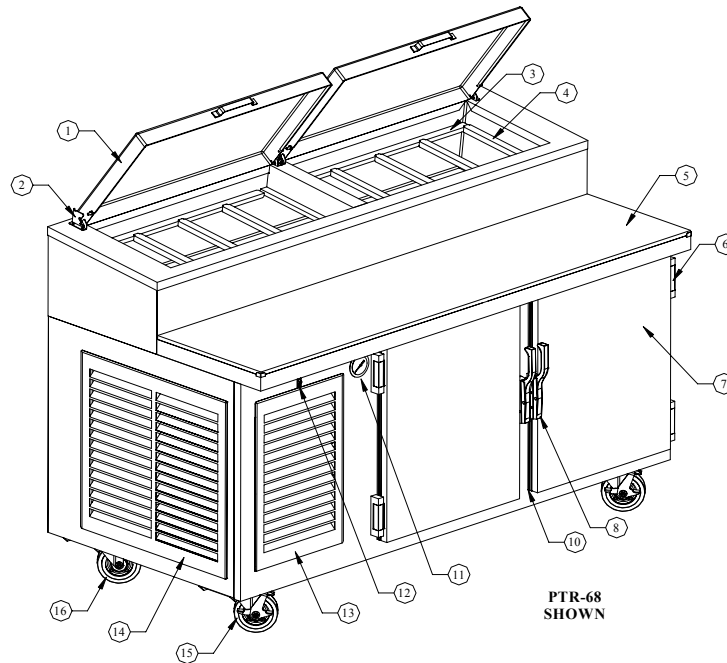

ITEM NUMBER	PART NUMBER	DESCRIPTION
1	S83562-0	Lid Assembly (PTR-68 & PTR-88)
	S21951-0	Lid Assembly (PTR-88)
2	90-9900	Lid Cover Bracket
3	S83440-0	Insert Side
4	S83442-0	End Dividers
5	9017-0	Thermoplastic Cutting Board (PTR-68)
	9018-0	Thermoplastic Cutting Board (PTR-88)
6	6053-8	Hinge & Cover
7	S81452-0	Door Assembly
8	6055-1	Slam Action Latch
9	S81407	Plastic Door Back
10	97-104	Door Gasket
11	113-5	Thermometer
12	1069-1	Front Switch
13	S84051-0	Front Grill (PTR-68)
	S84050-0	Front Grill (PTR-88)
14	S84053-0	End Grill (PTR-68 & PTR-88)
15	6012-11	Casters with Brakes
16	6012-10	Casters without Brakes
17	S84052-0	Back Grill (PT-68 & PT-88) (Not Shown)
18	S81454-0	Tray Rack Assembly (Not Shown)
19	69-973	Wire Shelf (Not Shown) (PTR-68 & 88)
20	22-1406	Thermostat for Base (Not Shown)
21	22-1397	Thermostat for Rail (Not Shown)

ITEM NUMBER	PART NUMBER	DESCRIPTION
22	2060-1	Cond. Water Evaporator (Not Shown)
23	1149-0	Wire Harness (Double) (PTR-88) (Not Shown)
	1150-0	Wire Harness (Single) (PTR-68) (Not Shown)
24	2029-3	1/4 H.P. Compressor (PTR-68 Base) (Not Shown)
	2002-4	1/3 H.P. Compressor (PTR-88 Base) (Not Shown)
	2029-6	1/3 H.P. Compressor (PTR-68 & PTR-88 Top Rail) (Not Shown)
25	100-1004	Power Cord (PT-68) (Not shown)
	1006-2	Power Cord (PT-88) (Not Shown)
26	2025-0	Drier (Base)
	2024-0	Drier (Top Rail)
27	2026-0	.042 Cap. Tube (Base)
28	494-54	1/4 Expansion Valve (Not Shown)
29	2013-0	Fan Motor (Not Shown)
30	S81441-0	Fan Guard (Not Shown) (PT-68)
	S51529-0	Fan Guard (Not Shown) (PT-88)
31	2014-5	Fan Blade (Not Shown)
32	S81419-0	Fan Bracket (Not Shown)
33	2119-0	Evap. Coil (PTR-68 Base) (Not Shown)
	2020-1	Evap. Coil (PTR-88 Base) (Not Shown)
34	6151-6	Pilaster (Not Shown)
35	6151-1	Snap-In Shelf Support (Not Shown)

PIZZA PREPARATION TABLE WITH RECESSED TOP

PTR SERIES

OPERATION

Location of the unit is important. There must be adequate ventilation for the compressors. A minimum clearance of 6 inches must be provided at the vent locations on the side and front of the unit.

The supply cord is accessible through the end grill, which pulls out. Extend the cord completely, snap grill back into place and plug into a proper outlet (see chart below).

MODEL NUMBER	AMPS	NEMA PLUG
PTR-68	12.6	5-20P
PTR-88	15.5	5-20P

These units are equipped with two (2) compressors and two (2) thermostats. The thermostat controlling the top cold rail is located in the compressor compartment and the thermostat that controls the bottom rail is located on the blower housing inside the refrigerator compartment. The thermostats have an off position and numbers from 1 through 7 (number 7 is the coldest).

The top condiment rail should be defrosted at least once a week by turning the thermostat to the off position.

DO NOT STORE ANY FOODS IN CONDIMENT RAIL WHILE DEFROSTING.

MAINTENANCE

NEVER CLEAN THE UNIT WITH A CHLORIDE BASED PRODUCT. CHLORIDES OR IMPROPER CLEANING COULD SCARE, MARK AND/OR CORRODE METAL. **DO NOT** USE STEEL WOOL OR ABRASIVE PRODUCTS. TO CLEAN USE SOAPY WARM WATER, RINSE RESIDUE THOROUGHLY.

FAILURE TO MEET THESE CONDITIONS WILL VOID WARRANTY.

CLEAN CONDENSER COIL REGULARLY.