

APPLICARE
TARGA
CARATTERISTICHE

INSTRUCTIONS - HANDBOOK
193 BAR USA

We wish to thank you for the preference granted to us by purchasing one of CARPIGIANI machines.

To the best guarantee, since 1993 Carpigiani has submitted its own Quality System to the certification according to the international Standard ISO 9001-94.

Moreover, Carpigiani machines comply with following European Directives:

- “Machinery” Directive 98/37/EC,
- “Low Voltage” Directive 73/23/EEC,
- “EMC” Directive 89/336/EEC,
- “PED” Directive 97/23/EC,
- Regulation 2004/1935/EC relating to “Materials and articles in contact with foodstuffs”

CARPIGIANI

Via Emilia, 45 - 40011 Anzola Emilia (Bologna) - Italy

Tel. 051-6505111 - Fax 051-732178

This handbook may not be reprinted, transferred, registered, recorded in a retrieval system, nor translated in other languages unless otherwise previously agreed with **CARPIGIANI**.

The purchaser has the right to reprint it for his own office use.

CARPIGIANI policy pursues a steady research and development, thus it reserves the right to make changes and revisions whenever deemed necessary and without being bound to previous statements to the purchaser.

INDEX

FOREWORD	5
INSTRUCTION HANDBOOK	5
PURPOSE	5
HANDBOOK STRUCTURE	5
ADDITIONAL DOCUMENTATION	5
CONVENTIONAL SYMBOLS	6
SAFETY	7
QUALIFICATION OF THE STAFF	7
WARNING	7
1 GENERAL INFORMATION	9
1.1 GENERAL INFORMATION	9
1.1.1 MANUFACTURER'S IDENTIFICATION DATA	9
1.1.2 INFORMATION ABOUT SERVICE	9
1.1.3 INFORMATION TO THE USERS	9
1.2 INFORMATION ABOUT THE MACHINE	9
1.2.1 GENERAL DATA	9
1.2.2 MACHINE LAY-OUT	10
1.2.3 TECHNICAL FEATURES	10
1.2.4 MACHINE SETS LOCATION	11
1.3 INTENDED USE	11
1.4 NOISE	11
1.5 STORING A MACHINE	11
1.6 DISPOSAL OF PACKING STUFFS	11
1.7 WEEE	11
2 INSTALLATION	13
2.1 ROOM NECESSARY TO THE MACHINE USE	13
2.2 MACHINE WITH AIRCOOLED CONDENSER	13
2.2.1 AIR FLOW	13
2.3 MACHINE WITH WATERCOOLED CONDENSER	14
2.3.1 WATER VALVE ADJUSTMENT	14
2.4 ELECTRIC CONNECTION	14
2.4.1 REPLACEMENT OF POWER SUPPLY CORD	14
2.5 LOCATION	14
2.6 REFILLING	14
2.7 MACHINE TESTING	14
3 DIRECTIONS FOR USE	15
3.1 MACHINE CONFIGURATION	15
3.2 ELECTRONIC CONTROL KEYBOARD AND BUTTON FUNCTIONS	15
3.3 SPIGOT HANDLE	17
3.4 "R" PUMP	17
3.5 GRAVITY-FEED MACHINE-FEEDING NEEDLE	17
3.6 PRELIMINARY OPERATIONS, WASHING AND SANITIZING	18
3.6.1 CLEANING	18
3.6.2 SANITIZING	20
3.6.3 HYGIENE	20
3.7 STARTING THE MACHINE	21
3.7.1 STARTING MACHINES WITH PUMP	21
3.7.2 STARTING GRAVITY-FED MACHINES	21
3.8 PRODUCTION	22
3.9 ALARMS	22
3.9.1 BLACKOUT	23
3.10 PROGRAMMING FOR THE USER	23
4 SAFETY DEVICES	25
4.1 SAFETY DEVICES ON THE MACHINE	25

5 DISASSEMBLING AND CLEANING THE PARTS IN CONTACT WITH MIX 27

5.1 PROGRAMMED CLEANING TIME 27

5.2 DRAINING AND CLEANING 27

5.3 PUMP FED MACHINES - DISASSEMBLING THE MIX PUMP 28

5.4 GRAVITY FED MACHINES - DISASSEMBLING FEEDING NEEDLE 28

5.5 DISASSEMBLE THE TANK MIXER 28

5.5 DISASSEMBLING FRONT LID 29

5.6 PUMP FED MACHINE - DISASSEMBLING THE BEATER 29

5.7 GRAVITY FED MACHINE - DISASSEMBLING THE BEATER 29

5.8 WASHING AND SANITIZING COMPONENTS 30

5.9 PUMP FED MACHINE - REASSEMBLING THE MIX PUMP 31

5.10 GRAVITY FED MACHINE - REASSEMBLING FEEDING NEEDLE 31

5.11 PUMP FED MACHINES - REASSEMBLING BEATER 32

5.12 GRAVITY FED MACHINES - REASSEMBLING BEATER 32

5.13 REASSEMBLING FRONT LID 32

5.14 SANITIZING THE WHOLE MACHINE 33

5.15 PRIMING THE MIX PUMP 33

6 MAINTENANCE 35

6.1 SERVICING TYPOLOGY 35

6.2 WATER COOLING 36

6.3 AIR COOLING 36

6.4 TABLE OF SPARE PARTS EQUIPMENT 37

7 TROUBLESHOOT GUIDE 39

FOREWORD

INSTRUCTION HANDBOOK

Editing this handbook, it was taken into due account European Community directions on safety standards as well as on free circulation of industrial products within E.C.

PURPOSE

This handbook was conceived taking machine users' needs into due account. Topics relevant to a correct use of the machine have been analyzed in order to keep unchanged in the long run quality features characterizing **CARPIGIANI** machines all over the world. A significant part of this handbook refers to the conditions necessary to the machine use and to the necessary procedure during cleanout as well as routine and special maintenance. Nevertheless, this handbook cannot meet all demands in details. In case of doubts or missing information, please apply to:

CARPIGIANI

Via Emilia, 45 - 40011 Anzola Emilia (Bologna) - Italy
Tel. 051- 6505111 - Fax 051-732178

HANDBOOK STRUCTURE

This handbook is divided in sections, chapters and subchapters in order to be consulted more easily.

SECTION

A section is the part of the handbook identifying a specific topic related to a machine part.

CHAPTER

A chapter is that part of a section describing an assembly or concept relevant to a machine part.

SUBCHAPTER

It is that part of a chapter detailing the specific component of a machine part.

It is necessary that each person involved in the machine operation reads and clearly understands those parts of the handbook of his/her own concern, and particularly:

- The Operator must read the chapters concerning the machine start-up and the operation of machine components.
- A skilled technician involved in the installation, maintenance, repair, etc., of the machine must read all parts of this handbook.

ADDITIONAL DOCUMENTATION

Along with an instruction manual, each machine is supplied also with additional documentation:

- **Part list:** A list of spare parts which is delivered together with the machine for its maintenance.
- **Wiring diagram:** A diagram of wiring connections is placed in the machine.

ATTENTION

**Before using the machine read carefully the instruction handbook.
Pay attention to the safety instructions.**



CONVENTIONAL SYMBOLS



CAUTION: ELECTRIC SHOCK DANGER

The staff involved is warned that the non-observance of safety rules in carrying out the operation described may cause an electric shock.



CAUTION: GENERAL HAZARD

The staff involved is warned that the operation described may cause injury if not performed following safety rules.



NOTE

It points out significant information for the staff involved.



WARNINGS

The staff involved is warned that the non-observance of warning may cause loss of data and damage to the machine.



PROTECTIONS

This symbol on the side means that the operator must use personal protection against an implicit risk of accident.

QUALIFICATION OF THE STAFF



MACHINE OPERATOR

He/she is an unskilled person, who has no specific expertise and can only carry out easy chores, such as the machine operation by means of controls available on the push-button panel, and filling and drawing of products used during operations.



MAINTENANCE ENGINEER

He/she is a skilled engineer for the operation of the machine under normal conditions; he/she is able to carry out interventions on mechanical parts and all adjustments, as well as maintenance and repairs. He/she is qualified for interventions on electrical and refrigeration components.



CARPIGIANI ENGINEER

He/she is a skilled engineer the manufacturer assigned to field interventions for complex jobs under particular conditions or in accordance with agreements made with the machine's owner.

SAFETY

When using industrial equipment and plants, one must be aware of the fact that drive mechanisms (rotary motion), high voltage components, as well as parts subject to high temperatures may cause serious damage to persons and things.

Who is in charge of plant safety must be on the look-out that

- An incorrect use or handling shall be avoided
- Safety devices must neither be removed nor tampered with
- The machine shall be regularly serviced
- Only original spare parts are to be used especially as far as those components with safety functions are concerned (ex.: protection microswitches, thermostats).

To achieve the above, the following is necessary:

- At the working place an instruction manual relevant to the machine should be available.
- Such documentation must be carefully read and requirements must consequently be met.
- Only adequately skilled personnel should be assigned to electrical equipment.
- Be on the look out that no technician will ever carry out interventions outside his own knowledge and responsibility sphere.



QUALIFICATION OF THE STAFF

Staff attached to the machine can be distinguished according to training and responsibility as follows:

OPERATOR

- A person who has not necessarily a high technical knowledge, just trained for ordinary operation of the machine, such as: startup, stop, filling, basic maintenance (cleanout, simple blocking, instrumentation checkings, etc.).

SKILLED ENGINEER

- A person engaged on more complicated operations of installation, maintenance, repairs, etc.

IMPORTANT!

One must be on the look-out that the staff does not carry out any operation outside its own sphere of knowledge and responsibility.

NOTE:

According to the standard at present in force, a SKILLED ENGINEER is who, thanks to

- *training, experience and education,*
 - *knowledge of rules, prescriptions and interventions on accident prevention,*
 - *knowledge of machine operating conditions,*
- is able to realize and avoid any danger and has also been allowed by the person in charge of plant safety to carry out all kinds of interventions.*

WARNING

When installing the machine, insert a differential magnetothermal protection switch on all poles of the line, adequately sized to the absorption power shown on machine data plate and with contact opening of 3 mm at least.

- Never put your hand into the machine, alike during production and cleaning operations.
Before carrying out any maintenance operation, make sure that the machine is in “STOP” position and main switch has been cut out.
- It is forbidden to wash the machine by means of a bolt of water under pressure.
- It is forbidden to remove panels in order to reach the machine inside before having disconnected the machine.
- **CARPIGIANI** is not responsible for any accident that might happen during operation, cleaning and/or servicing of its units, if this warning has not been fully complied with.



1 GENERAL INFORMATION

1.1 GENERAL INFORMATION

1.1.1 Manufacturer's identification data

The machine has a data plate carrying manufacturer data, machine type and serial number, assigned when it is manufactured.

Copy of machine data plate to be found on first page of this handbook.

EQUIPMENT DATA PLATE INFORMATION			
Mixer - Model - Series, North Carolina			
MODEL NO. _____			
SERIAL NO. _____		DATE _____	
VOLTS _____		PHASE _____ HZ _____	
MAX. BREAKER/FUSE SIZE _____ AMP			
MINIMUM CIRCUIT CAPACITY _____			
		DESIGN PRES.	OPERATING PRES.
HIGH SIDE PSIG			
LOW SIDE PSIG			
REFRIGERANT _____ AMOUNT _____ OZ			
	BEATER	COMPRESSOR	FAN
QTY			
HP			
FLA			
LRA			

1.1.2 Information about service

All operations of routine maintenance are here described in section "Maintenance"; any additional operation requiring technical intervention on the machine must be cleared with the manufacturer, who will also examine the possibility of a factory technician field intervention.

1.1.3 Information to the user

- The manufacturer of the machine is at user's disposal for any explanation and information about the machine operation.
- In case of need, please call the local distributor, or the manufacturer if no distributor is available.
- Manufacturer's service department is available for any information about operation, and requests of spare parts and service.



1.2 INFORMATION ABOUT THE MACHINE

1.2.1 General data

Counter-top machine to immediately produce and distribute soft express ice cream in two flavours + mixed, available with pump to ensure a higher overrun.

CARPIGIANI recommends to always use high quality mix for ice cream production in order to satisfy your customers, even the most hard-to-please ones. Any saving made to the prejudice of quality will surely turn into a loss much bigger than the saving itself.

Bearing in mind the above statements, please take heed of the following suggestions:

- Make your mixes yourselves from high quality natural ingredients or buy them from reliable companies.
- Follow closely instructions given by your mix supplier for the preparation of the mixes.
- Do not alter your mix supplier's recipes, by adding, for instance, water or sugar.
- Taste ice cream before serving it and start selling it only if entirely satisfactory.
- Make sure your staff always keeps the machine clean.
- Have your machine serviced always by companies authorized by CARPIGANI.

1.2.2 Machine layout

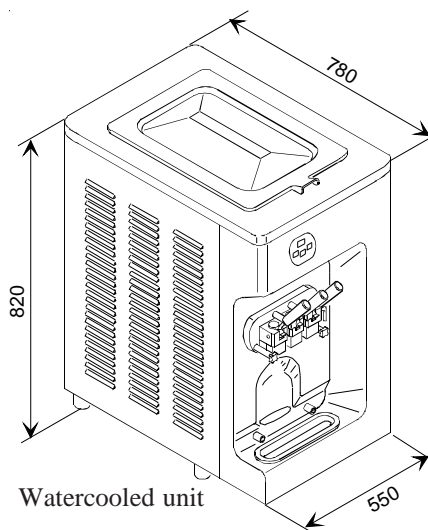
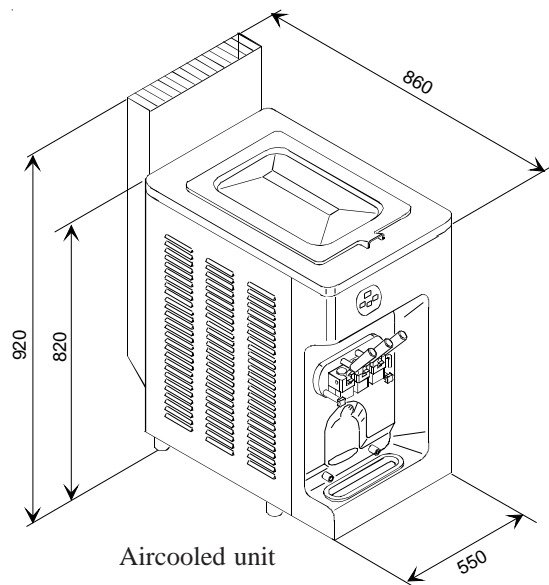

1.2.3 Technical features

MODEL	Hourly production * 40Z portions/h	Hopper capacity qts.	Flavors	Electrical supply			Installed power kW	Net weight lb.
				Volt	Phase	Cycle		
193 BAR	300	17+17	2 + mixed	208-230	3	60	4,2	473

* Hour output may vary depending on mix used
Performances featured by a room temperature of 77°F and a water temperature of 68°F.

1.2.4 Machine sets location

caption:

- 1 control panel
- 2 Freezing cylinder front lid
- 3 Drip tray shelf
- 4 Mix tank cover
- 5 DX and SX (right and left) drip tubes
- 6 Drip drawer

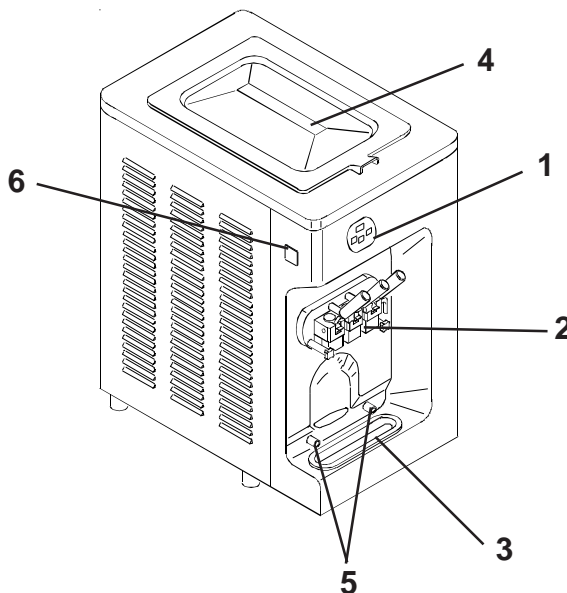

1.3 INTENDED USE

The machines must be used solely for the purpose described in chapter 1.2.1, "General information" within the functional limits described below.

Voltage	±5%
Min air temperature	50°F
Max air temperature	110°F
Min water temperature	50°F
Max water temperature	85°F
Min. water pressure	0,1 MPa (1 bar)
Max water pressure	0,8 MPa (8 bar)
Max relative humidity	85%

The machine has been designed for its use in places which are not subject to explosion-proof standards; its use is thus bound to conforming places and normal atmosphere

1.4 NOISE

The steady acoustic pressure level weighed A in a working place alike by watercooled and by aircooled machines is less than 70 dB(A).

1.5 STORING A MACHINE

The machine must be stored in a dry and dust-free place.
Before storing the machine, wrap it in a cloth in order to protect it against dust and else.

1.6 DISPOSAL OF PACKING STUFFS

When opening the packing crate, divide packing stuffs per type and get rid of them according to laws in force in machine installation country.

1.7 WEEE (Waste Electrical and Electronic Equipment)

In accordance with European Directive 2002/96/EC on WEEE (Waste Electrical and Electronic Equipment), the presence of the above symbol on the product or on its packaging indicates that this item must not be disposed of in the normal unsorted municipal waste stream. Instead, it is the user's responsibility to dispose of this product by returning it to a collection point designated for the recycling of electrical and electronic equipment waste. Separate collection of this waste helps to optimize the recovery and recycling of any reclaimable materials and also reduces the impact on human health and the environment. For more information concerning the correct disposal of this product, please contact your local authority or the retailer where this product was purchased.



2. INSTALLATION

2.1 ROOM NECESSARY TO THE MACHINE USE

The machine must be installed in such a way that air can freely circulate allaround. Rooms for the approach to the machine must be left free in order to enable the operator to act without constraint and also to immediately leave working area, if need be.

ATTENTION

Machines with aircooled condenser must be installed no closer than 8 cm to any wall in order to allow free air circulation around the condenser.

NOTE

An insufficient air circulation affects operation and output capacity of the machine.

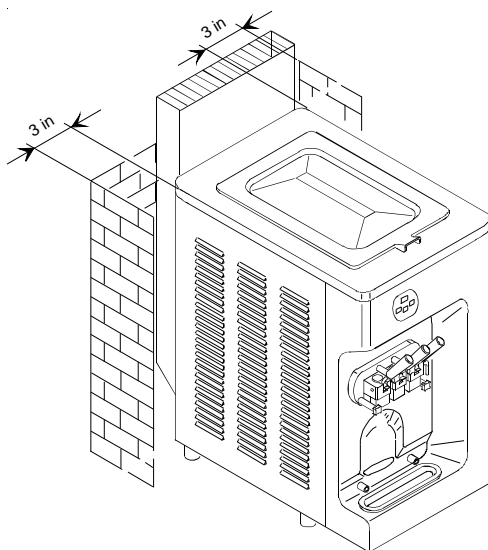

2.2 MACHINE WITH AIRCOOLED CONDENSER

Machines with aircooled condenser must be installed no closer than 8 cm to any wall in order to allow free air circulation around the condenser.

NOTE

An insufficient air circulation affects operation and output capacity of the machine.



2.2.1 Air flow

The machine is provided with an internal fan motor which takes fresh air from the right panel of the machine and exhausts the heated air through the left panels and through the stack on the rear of the machine

IMPORTANT

Do not place topping containers, syrup containers or other products, in front of the left panel of the machine because the hot air flow increases the temperature of the products or may melt them.

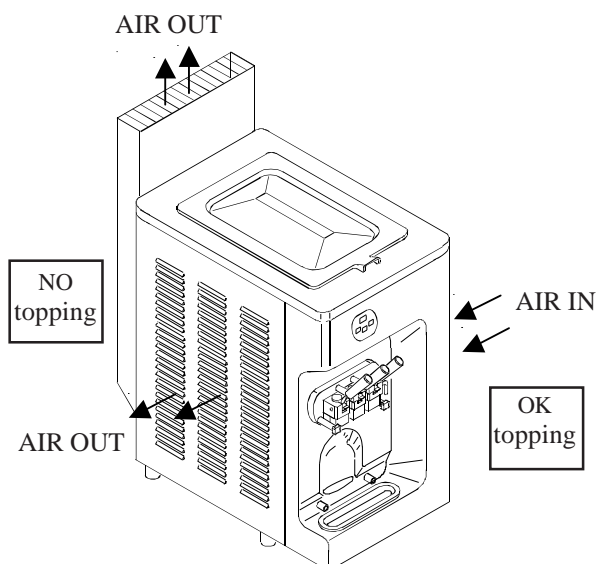



2.3 MACHINES WITH WATERCOOLED CONDENSER

To make the machine run, a watercooled machine must be connected to running water supply, or to a cooling tower. Water must have a pressure of 1 Bar at least and a delivery at least equal to the estimated hourly consumption. Connect inlet pipe marked by plate "Water Inlet" to water supply installing a shut-off valve, and outlet pipe marked by plate "Water Outlet" to a drain pipe, installing a shut-off valve.

2.3.1 Water valve adjustment

WARNING

If water valve must be reset, this operation will have to be carried out by skilled personnel, only. Valve adjustment must be carried out in such a way that no water flows when machine is off and lukewarm water flows when machine is on.

NOTE:

Water consumption increases if temperature of entering water is above 68°F.

ATTENTION:

Do not leave the machine in a room with temperature below 32°F without first draining water from the condenser.

2.4 ELECTRIC CONNECTION

Before connecting the machine to the mains, check that machine voltage indicated in data plate corresponds with the mains (see sec. 1.1.1 point C).

Insert a differential magnetothermal protection switch adequately sized to absorption capacity required (see sec. 1.1.1 point D) and with contact opening of 3 mm at least.

WARNING

Yellow/green ground wire must be connected to a good ground outlet.

Rotation direction by three-phased machines

The beater rotates anticlockwise.

Reversing rotation direction

To reverse the direction rotation, when wrong, it is necessary to interchange two of the three leads coming from the circuit breaker.

2.4.1 Replacement of power supply cord

If the machine main cable is damaged, it must be replaced through a cable with similar features. Replacement will have to be carried out by skilled technicians only.

2.5 LOCATION

Level the machine on the counter surface to ensure smooth operation and prevent mix from leaking.

2.6 REFILLING

Motor installed in the machine is of the type with lubrication for life; no action of checking/replacing or topping up is necessary. Gas filling necessary to the freezing system is carried out at CARPIGIANI works during machine postproduction testing. If a gas addition happens to be made, this must be carried out by skilled technicians, only, who can also find out trouble origin.

2.7 MACHINE TESTING

A postproduction test of the machine is carried out at Carpigiani premises; Operation and output functionality of the machine are thoroughly tested. Machine test at end user's must be carried out by skilled technicians or by one of CARPIGIANI engineers. After the machine positioning and correct connections, also carry out all operations necessary to functional check and test of the machine.



3. DIRECTION FOR USE

3.1 MACHINE CONFIGURATION

The machine has a motor to drive the beater, and a cooling system with water or air condenser. Soft ice cream is prepared by filling the tanks with **cold mix (+39°F)** and starting the automatic production cycle, until the ideal ice cream consistency set by CARPIGIANI is reached. Thanks to the pump, the mix enters the freezing cylinder already mixed with air; ice cream is produced only when it needs to be served. The spigot head allows a single portion of soft ice cream to be distributed. At the same time, the same amount of mix moves from the tanks into the freezing cylinders.

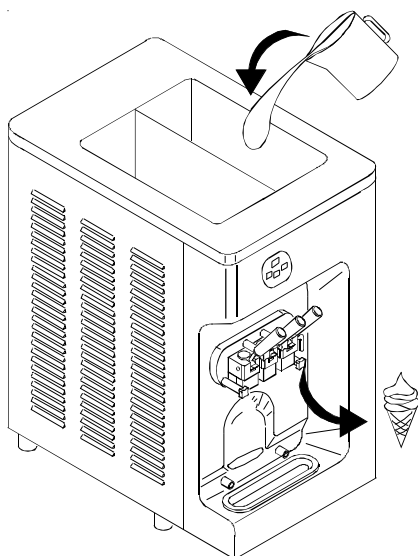

3.2 ELECTRONIC CONTROL KEYBOARD AND BUTTON FUNCTIONS

Details of the panel are shown in the picture below.



Display

On turning on the machine and during its operation, a series of messages are displayed on the screen.

Led indicators

The led indicator lights up to show that the function corresponding to the symbol is activated.

STOP button



With Stop function inserted, the led lights on, the machine is ready to receive commands for any of the main functions. From STOP you have access to all functions. In order to change function you must always go back to STOP.

From START and/or STORAGE push and hold STOP at least two seconds in order to turn the machine OFF.

If machine is turned in STOP from START/STORAGE for longer then 30", the display will blink and will show "Why in STOP ???" as a warning message.

PRODUCTIONfunction



When selecting this function the led lights up and the mix into the cylinder is freezed until its set consistency (pre-set HOT setting) is reached.

As soon as the START button is press, the display will show the differente possibilities in product that the machine can produce as follow:

SoftIce	SoftIce
WaterIce	SoftIce
SoftIce	WaterIce
WaterIc	WaterIc

Once the display shows the desired combination, please wait 3 seconds then the machine will start automatically the production of the choosen product.



STORAGEfunction

When selecting this function, led lights up and the machine stores the mix both in hopper and cylinder at a pre-set temperature of +39°F.

Note: It is advisable to leave the machine in this function in case of extended idle times.



CLEANINGfunction

When selecting this function, led lights up, the beater and the mix pump run, while the refrigeration unit is off. This function is timed and ends automatically when the set time is reached.

Note: Too an extended operation time is not advisable.



PASTEURIZINGfunction

Disabled function



Tank mix level

Low mix level in the tank is only indicated by the display.

Low level on the left side is indicated on display by a message "Mix Out Left":

Low level on the right side is indicated on display by a message "Mix Out Right":

Such a condition in Production allows the distribution of the set number of cones, only.



3.3 SPIGOT HANDLE

In order to dispense the product, place a cup or a cone under the spout and slowly pull down the dispensing handle. As soon as the product comes out, twist the cup or the cone to form a cone-shaped serving. When the portion has reached the desired size, close the dispensing handle and quickly pull the cone or the cup down in order to sharpen the tip.

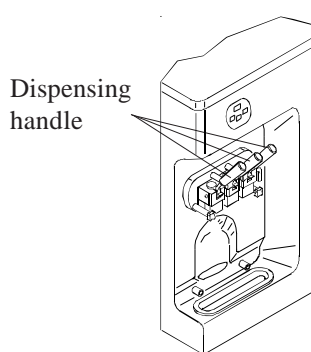

3.4 PUMP - FED MACHINES - "R" PUMP

"R" pump allows, by changing position of regulator pos. 271, to vary proportions between air and mix conveyed to the freezing cylinder; so, within certain limits, it allows overrun regulation depending on mix used.

"R" pump regulator should be set to the middle position.

If, after dispensing a significant number of cones, ice cream is too heavy and wet, you may move R pump regulator a notch at a time towards the right. If ice cream comes out of spigot mixed with air bubbles, then turn R pump regulator a notch at a time towards the left.

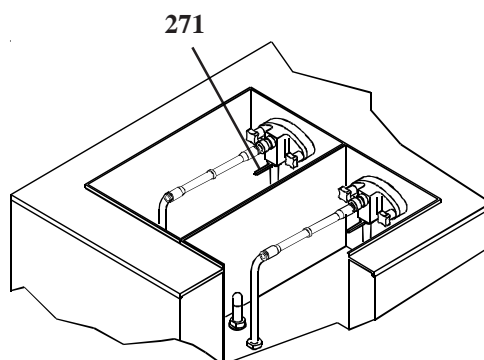

3.5 GRAVITY - FEED MACHINE - FEEDING NEEDLE

How to obtain and how to keep quality performances.

1. Maintain a big mix level inside the hopper (above the half of the hopper itself). Mix temperature inside the hopper is +39°F both during production and storage
2. During the day the mix must periodically be stirred by use of a plastic spatula to avoid separation, particularly when product has not been dispensed over a long period and the machine has been in "storage" mode for a long time.
3. A fluid mix without particles has to be used. A thick mix with big particles could close the slot of the feeding needle thus blocking mix from entering the cylinder.
4. Keep the feeding needle slider (pos. 52) in a position as to allow for a smooth mix flow from the hopper. By rotating the slider slot to the whole with smaller diameter, the quantity of mix to the tank will decrease, and vice versa.
5. Set the feeding needle in such a way that inlet hole is turned towards the middle of the tank.
6. Never exceed production limits in kilograms declared by Carpigiani, and dispense cones and cups in the most regular way. If limits in production capacity as specified by Carpigiani are exceeded the machine could stop. In this case appear on the display the alarm signal "ICE". If this occurs to reset the machine please operate as follow.
 - stop the machine (pressing the push button to the STOP position)
 - remove the feeding needle to enable a quick drop of the mix into the cylinder
 - set machine in the "cleaning" position for a few minutes
 - make sure that the product coming out for the spigot body when dispensing is liquid
 - position the feeding needle again making sure the slider is sufficiently open
 - start the machine putting it in the "production" mode. Do not start dispensing product from the machine until the production cycle has been completed.

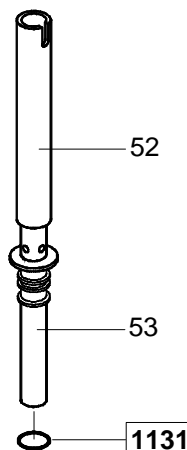



3.6 PRELIMINARY OPERATIONS, WASHING AND SANITIZING

Before starting the machine for the first time, it is necessary to thoroughly clean its parts and sanitize all parts coming into contact with the mix.

WARNING

Cleanout and sanitization must be carried out every day, as a habit and with utmost care, in order to secure quality of production in the observance of healthy rules.

3.6.1 Cleaning

Lift tank cover and from its inside take out bag containing accessories, instruction booklet and warranty sheet.

Remove the tank cover

By pump-fed machines:

- Disconnect the connection pipe (pos. 207) by turning it to match with the hole and free it from the pin found on the pump cover.
- Pull the connection pipe backwards and remove the feeding pipe (pos. 32) by turning it by 90° then pulling upwards.
- Remove the tank mixer (pos. 162) by pulling it upwards.
- Removing the pump by turning it clockwise of 45° then pull backwards.
- Disassemble the pump (see section 5 of this manual).

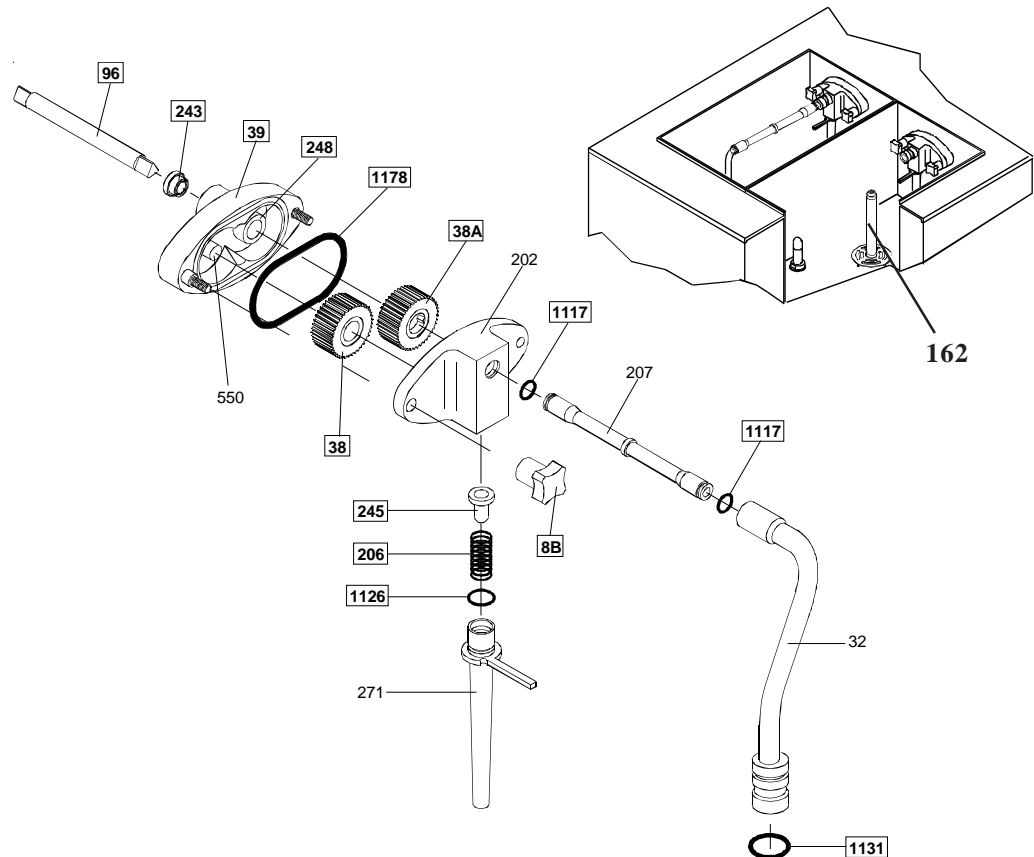

By gravity-fed machines:

- Extract the feeding needle slider (pos. 52), withdraw the slider from the tank bottom and remove the OR (pos. 1131).

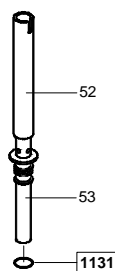

Removing the front lid

Remove the two retaining knobs (pos. 8A) and pull the lid assembly towards you, sliding it off the two front panel studs. Pull the dispensing handle (pos. 5) so the pistons (pos. 30 and 302) raises in its housing. Remove the pivot pin O-ring (pos. 1285) and pull the pivot pin (pos. 6) out releasing the dispensing handle (pos. 5). Using the dispensing handle lever pull the pistons (pos. 30 and 302) out completely. Using the o-ring extractor, remove the o-rings (pos. 303, 1153 and 1188).

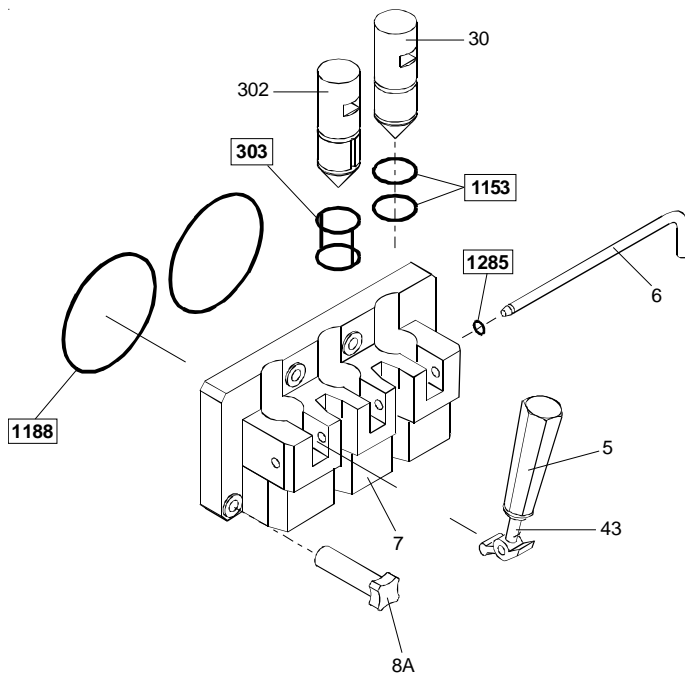

By pump-fed machine: Removing the beater

Pull the beater out of the cylinder. Slide the beater seal (pos. 28) out of the beater shaft. Pull out and remove the end pusher (pos. 25P) and the idler (pos. 24). Remove the 3 beater blades (pos. 430).

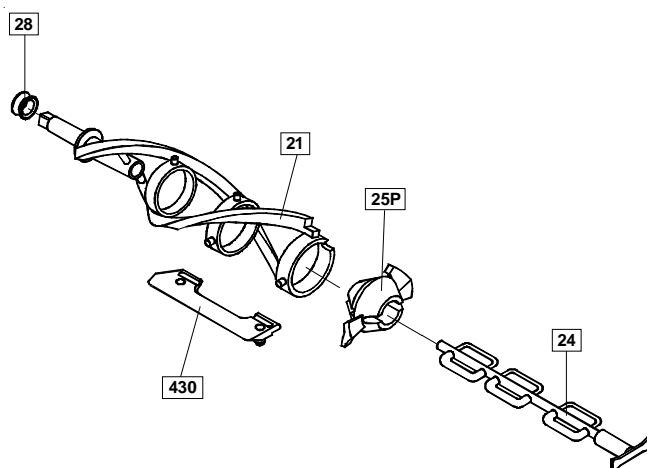

By gravity-fed machine: Removing the beater

Pull the beater out of the cylinder. Slide the beater seal (pos. 28) out of the beater shaft.

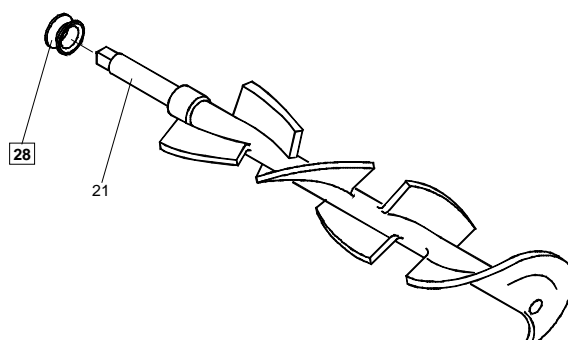

- 1- Fill a clean sink with detergent and hot water (122-140°F).
- 2- Wash the disassembled parts with the solution and scrub them thoroughly with the brushes provided with the machine. As you proceed, rinse with hot water. Make sure all lubricant and mix film is removed from the parts.
- 3- Mix the sanitizer into a clean pail with at least two gallons of warm water. Mix the sanitizer and water to make 100 PPM concentration of sanitizer solution. Using the spatula, stir the solution until the sanitizer is completely dissolved.
- 4- Place the parts into the sanitizing solution. Leave them there at least 1 minute (**using the sanitizing solution, sanitizer manufacturers' directions are to be followed**).
- 5- Place the components on a clean tray to air-dry.
- 6- Return to the machine with a small amount of sanitizer.
- 7- Dip a brush into the sanitizer and thoroughly brush the freezing cylinder
- 8- Dip the brush Pos. 772D (D. 30x640) into the sanitizer and thoroughly brush the drip pipe.
- 9- Dip a brush into the sanitizer and thoroughly brush clean the mix inlet hole and the pump drive hub opening in the rear mix tank.
- 10- Spray the back of cylinders and the tankwalls with sanitizer.

Repeat step 7, 8, 9 and 10 several times

Reassemble the tank mixer.

Reassemble and place the compression tubes (see section 5 of this manual) into the tanks and connect to the pumps only when cleaning operations are complete.

Reassemble the pumps (see section 5 of this manual), making sure to use food-grade lubricant on all o-ring and insert them into the tanks

Reassemble the beater (see section 5 of this manual), insert it completely into the freezing cylinder, by grasping it with both hands.



WARNING

Insert the beater minding not to hit it against the cylinder wall, since you might scratch it and so jeopardize the correct machine operation.

Reassemble the front lid (see section 5 of this manual) and install it back.

Place the cover back.

3.6.2 Sanitizing



CAUTION

For the use of sanitizers, instructions on labels are to be followed.



The machine must be sanitized before mix is poured in. Proceed as follows:

- 1- Fill the tanks to their maximum levels with sanitizer (mix the sanitizer and water to make 100 PPM concentration of sanitizer solution) and allow to drain into the cylinders.
- 2- Using the brush, clean the mix level sensors, the entire surface of the mix tanks and the surface of the mix pumps.
- 3- Select CLENOUT function and let the beater run about 10 seconds. Press the STOP button. Cylinders and pumps are now filled with sanitizing solution.
- 4- Return to the machine with a small amount of sanitizer solution in a pail.
- 5- Dip the front lid brush in the pail of sanitizer and brush clean the dispensing spout. Repeat twice.
- 6- Wipe the exterior of machine with a clean sanitized towel. Repeat twice.
- 7- Wait for at least 5 minutes before proceeding with the next instructions.
- 8- Place an empty pail under the front lid and pull the handles
- 9- Allow all of the sanitizer to drain. If the sanitizing solution does not flow out completely, keep the spigot open and select CLENOUT function, keep the beater running 5 seconds so that the last solution residues flow out, then push STOP.

CAUTION

Do not keep the beater running more than the time strictly needed to complete washing and sanitizing.

3.6.3 Hygiene

Mildew and bacteria grow rapidly in the ice cream fat contents. To eliminate them, it is necessary to thoroughly wash and clean all parts in contact with mix and ice cream, as described above. Stainless steel and plastic materials, as well as rubber used in the construction and also their particular shapes make cleanout easy, but cannot prevent proliferation of mildew and bacteria if not properly cleaned.



3.7 STARTING THE MACHINE

After installing the machine according to the instructions given in the chapter INSTALLATION, and after carefully cleaning and sanitizing the machine, proceed as follows:



3.7.1 Starting machines with pump

Remove the compression pipes from tanks bottoms and place them in the sanitizing solution.

Filing the tanks :

- Take 1 bag of mix from the refrigerator.
NB.: Mix to be poured at a temperature of 41°F.
- Pour one bag of mix into each tank allowing it to be conveyed into the freezing cylinders. Mix level in the tank must never reach the pump (see picture) and more mix must be added when level goes below about 1 inch. from tank bottom.
- Lower the distribution handles and wait until only full strength mix will come out of the lid; close the handles.

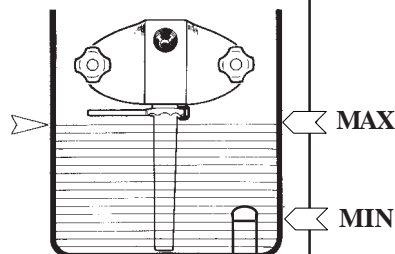

Connecting the mix pressure pipe :

- Keep on pouring the mix and wait till the cylinders have been completely filled (during that time you see bubbles in the tanks); with sanitized hands, draw the compression pipes out from the sanitizing solution and insert them into relevant tank bottoms.
- Turn the compression pipes clockwise and align them to the pump, insert the connection pipes (pos. 207) well into the compression pipes, then into the pumps and lock them. Mix inside the tanks shall never reach the pump (see the picture); furthermore mix shall be added whenever level is 1 inch. from tank bottom.
- Place tank covers back.
- Select the function Production and after a few minutes, ice cream is ready for distribution.

3.7.2 Starting gravity-fed machines

Remove the feeding needle from tank bottom and place it in the sanitizer solution.

Prime Hopper :

- Retrieve 1 bag of mix from the walk-in refrigerator.
NB.: Mix to be poured at a temperature of 41°F.
- With the draw handle open, pour one bag of mix into the hopper allowing it to drain into the freezing cylinder. Mix level in the tank must never exceed feeding needle height (see picture) and more mix must be added when level goes below about 1 inch. from tank bottom.
- When only full strength mix (not mix and sanitizer) is flowing from the draw spout, close the draw handle.

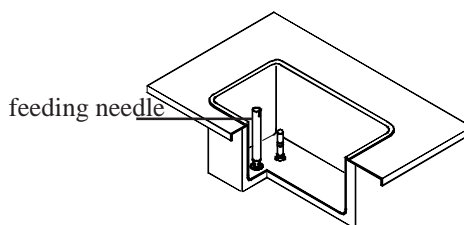

Connect the feeding needle:

- When the mix stops bubbling from the bottom of the hopper, take the mix feeding needle from the sanitizing solution and insert it in its position in the bottom of the hopper. Make sure your hands are clean and sanitized.
- Select production function to start the Automatic freezing operation.
- Replace the hopper cover.



3.8 PRODUCTION

Dispense icecream without exceeding the machine production rate as shown in the table on page 10. If you do not exceed it, and provide to refill the machine with fresh mix, you can be sure you will never have to stop selling, even during peak hours.

When the message Mix Out Right it means that the mix has reached the minimum level in the right-hand tank and, as a consequence, more mix must be added because the machine would dispense a programmed number of cones, and then it would automatically set to Storage. If the mix has reached the minimum level in the left-hand tank, the display indicates Mix out Left.

During closing time of the store, set your machine to STORAGE by pressing STOP and STORAGE key.

You will save significantly on energy consumption, as the compressor runs only for the time strictly necessary in order to keep product at its correct temperature.

When you reopen the store, set the machine to STOP and then to PRODUCTION. Within a few minutes youghourt icecream will be back at the correct consistency for sale.

If the machine has been stopped a long time due to a power failure, it is necessary that you check product temperature before starting the sale again; if the temperature is over 41°F, the machine must be emptied, cleaned and sanitized, and filled up with new fresh mix at 38°F.

3.9 ALARMS



The machine issues possible alarm messages on the display and makes the writing blink. In case of alarm which has reset, the writing will be on display in a fixed way (it will not blink).

To reset the writing, press Storage/Reset key 

The machine can be used in ice cream production even if an alarm is active; if it is a critical alarm, the machine will not allow you to select ice cream production program; should this be the case, press STOP and do not use the machine till it is repaired.

Here below is the alarm list:

ALARM	DESCRIPTION
Mix out	The display indicates Mix Esaurita-Mix Out when the mix is below the level sensor. When the mix is below the low level sensor and in Production you distribute a number of cones same as/or higher than the value set in step Ultimi Coni- Last Cones, not only will Mix Esaurita- Mix Out - be displayed, but also your machine will move to Storage mode.
Overload Beater 1	Overload beater (bimetallic) motor relevant to cylinder 1 tripped. Machine sets at Stop mode.
Overload Beater 2	Overload beater (bimetallic) motor relevant to cylinder 2 tripped. Machine sets at Stop mode
Pressure Switch	Pressure Switch tripped. Machine sets at Stop: - after the 3rd tripping occurring within 1 hour - if pressure switch contact is opened 2 minutes running. If the machine was in Pasteurization mode, Pasteurization program shall be re-executed. Check cooling water flow (in water cooled units).
Overload Compres	Overload Compressor Motor. Machine sets to Stop.
Al. Hopper Probe	Hopper sensor faulty. This is a critical alarm: consequently, the machine sets at Stop, either from Production or from Storage and Pasteurization modes.
Al. Cylind.Probe 1	Cylinder sensor faulty. This is a critical alarm: consequently, the machine sets at Stop, from the Storage and Pasteurization modes, it does not however set at Stop from production because consistency is controlled.
Al. Cylind.Probe 2	Cylinder 2 sensor faulty. This is a critical alarm: consequently, the machine sets at Stop, from the Storage and Pasteurization modes; it stays in the same function when in production mode, because consistency is controlled
Al. IceHop.Probe	Tank evaporator sensor faulty. This alarm does not cause a machine (which is in the running function) to stop. In Pasteurizing Heating mode the alarm is eliminated.
Spigot Opened	Safety Magnet Switch. If opened 10 sec., it resets Wash message (Wash). IMS opening also resets Pasteurization flag, so that if the machine was in Pasteur. mode, you can directly enter in Production by opening and closing the front lid.
Al. Evapor.Probe 1	Alarm Cylinder 1 evaporator sensor. This alarm does not cause a machine (which is in the running function) to stop. In Pasteurization Heating mode the alarm is eliminated.
Al. Evapor.Probe 2	Alarm Cylinder 2 evaporator sensor. This alarm does not cause the machine (which is in the running function) to stop. In Pasteurization Heating mode the alarm is eliminated.

ALARM	DESCRIPTION
Power on	Power return after a blackout. Check blackout table in Pasteurization and Production. Event stored in all functions.
Ice Cylinder	Cylinder defrost read by sensors TE. In Production, if one of the two TE becomes lower than the value set in the step Ghiaccio cilin., Ice Cylinder, the machine sets at the status of "HOT reached" and stores the alarm Ghiaccio Cilin. Ice Cylinder among the events. The alarm might be caused by an insufficient feeding to the cylinder. Check the pump efficiency. When the temperature in the cylinder raises back, the alarm resets. If the alarm is instead displayed in Stop, it is necessary to check/replace TE sensor TE, because the temperature end scale is read by the CPU.
Timeout Prd.	In Production, starting time of the beater motor is checked. If the beater motor is ON for 6 minutes (Timeout Prd.) and Hot has not been reached, the machine sets to a "reached-HOT state" with alarm "Timeout Prd." in the events. The Timer will be reset on MIR and on MA starting. Check mix charge in cylinder, pump in the hopper and freezing unit.
Belt alarm	In Heating Pasteurization, if the temperature TGV2 becomes > than TEV1 value programmed in step DELTA TGV-TEV usually 86°F - 30°C), "Allarme cinghia- Belt alarm" is displayed and the machine sets to Stop. Check the driving belt or if the rotor is in its seat. Warning: this alarm is not active if TEV or TGV is inhibited.
Wash in n days	In Production, "Lavare tra n gg" Wash in n days is displayed: this means that n days remain until machine wash. Alarm Wash might also be caused by leaving machine in stop for 24 hours with mix above the level sensor See weekly cleaning
Do not Serve	In Production, every time consistency value goes below the one programmed in step Blocco Hot, cone red led lights up to indicate wait until ice cream is ready and "Attendi!" Wait! shows on the display. If, in such a case, you try to distribute cones, all units stop (MA and MC) till the photocell is no longer busy. As soon as it is set free, both MA and MC re-start in order to bring ice cream to its proper consistency.
Invert Phases	It is necessary to exchange 2 phases on the three-phase line in order to get the correct beater rotation direction. The alarm resets by switching power off and on again (after exchanging the phases).
Why in STOP	If the machine is left in the Stop position with mix covering the level sensor, the message "Why in STOP?" will be displayed 30 seconds later and an intermittent beep will be emitted. All this to warn the user to set the machine to Production, Pasteurization or Storage. Above mentioned message will be deleted by entering Production, having low mix level, or pressing Reset (Stor.) key. To have the message back on the display, it is necessary to first enter Production, Storage or Pasteurization.

3.9.1 Blackout

In the event of a blackout, if the machine was in functions mentioned below, namely

- in Cleaning, on power return, it sets to STOP;
- in Production or Storage: on power return, the machine sets back to the function where it was before the "blackout" on display.







3.10 PROGRAMMING FOR THE USER

1) For access to the Programming User (Manager Menu) press the Stop and Storage keys at the same time and soon release them.

The first step of programming User is now displayed.

Hours
Step U01 10

The first line is relevant to the description and the second one to the step number (U=User) and to the value.

2) Press Increment  or Decrement  keys to change the value.

Press Stop  to enter the next step. See programming table.

3) To exit from programming, do not press any key for 30 seconds or press Production or Cleaning. Machine returns to Stop, now.

STEP	DESCRIPTION
U01	Hours
U02	Minutes
U03	Day of Week
U04	Day of Month
U05	Month
U06	Year
U07	Language
U08	Start Prod. Time
U09	Start Pasto Time
U10	Lev. Beep Enable
U11	Active Side
U12	Fruit Side

4. SAFETY DEVICES

4.1 SAFETY SYSTEMS ON THE MACHINE

PRESSURESWITCH

It protects the refrigeration system and causes the compressor to stop if the pressure of the system exceeds the pressure switch setting value. This may occur especially due to a lack of water (machine with water condenser) or air circulation problems (machine with air condenser). The switch resets itself automatically.



WARNING

if the compressor runs for an excessive time or stops and starts repeatedly, this indicates insufficient condensation; check the causes.



OPERATOR PROTECTIONS

Safety microswitch on the lid.

A microswitch is located on the lid of the beating cylinder, containing the beating unit, which stops the machine immediately when the lid is opened. The machine enters STOP mode and the display shows the message "Front lid open".

When the lid is closed back, the machine remains stopped and shuts off the alarm on the monitor.



WARNING

Always make sure that the machine is in STOP mode before opening the lid.



5. DISASSEMBLING AND CLEANING THE PARTS IN CONTACT WITH MIX

Use a mild detergent to wash the parts.

Wash (by hands) the parts in water (at max 140°F), using a mild detergent and the accessory brushes. Use neither dish-washing machines, no detergents intended for them.

For rinse, use (bacteria free) drinking water.

For sanitizing, leave the parts in sanitized lukewarm water 10 to 15 minutes (**using the sanitizing solution, the sanitizer manufacturers' directions are to be followed**) and rinse before reassembling them.



5.1 PROGRAMMED CLEANING TIME

WARNING

Cleanout and sanitization must be carried out every day, as a habit and with utmost care, in order to guarantee quality of production in the observance of healthy rules.



5.2 DRAINING AND CLEANING

1. Place an empty pail under the spout.
2. Press the STOP button.
3. Pull the dispensing levers and drain the ice cream.
4. Select CLENOUT function.
5. When the product coming out becomes liquid, push STOP button and leave the spout open.
6. Remove the hopper cover.
7. For the pump fed machine: disconnect the connection pipes (pos. 207) from pumps and compression pipes (pos. 32), turn the latter by 90° and lift them in order to take them out from their own seats inside the tanks. Wait until all the product has flown out from tanks, now. Disassemble the pumps by turning them clockwise by 45° and pulling them towards you.
8. For the gravity fed machine: remove the feeding needle.
9. Wait until the liquid mix flows out completely and then set the distribution handles back to closing position. Fill the tanks with 2,5 gal. clean water. Clean tank walls and level sensor with the brushes provided. With a smaller brush, also clean pump and compression pipe seats.
10. Place an empty pail under spout. Open the spigot piston and let the water drain out.
11. Rinse with warm water until the solution runs clear.
12. Select CLENOUT function and let the beater run for 10 seconds.
13. Turn the machine off by pushing the STOP button and let the water flow out.
14. Fill the tanks with 2,5 gal. of warm detergent solution.
15. Clean tank walls and level sensors with the brushes. With a smaller one also clean pump and compression pipe seats.
16. Pull the dispensing handle and let the liquid flow out completely.
17. Rinse with clear water, pull the spigot handles and let water flow out.
18. Mix the sanitizer into the clean pail with at least two gallons of warm water. Mix the sanitizer and water to make a 100 PPM concentration of sanitizer solution. Using the spatula, stir the solution until the sanitizer is completely dissolved. Use the white tank brush to scrub the mix tank and mix level sensor. Use the small brush to clean the mix inlet hole and the drive hub of the mix pump.
19. Select CLENOUT function and let the beater run 10 seconds.
20. Push the STOP button. Leave the Sanitizing solution at least 1 minute inside.
21. Pull the dispensing handle and let water flow completely out.



5.3 PUMP FED MACHINES - DISASSEMBLING MIX PUMP



1. Take the connection pipes (pos. 207) out from the pumps and compression pipes pos. 32). Turn DX and SX compression pipes 90° anticlockwise and lift them while taking them out from their seats inside the tanks. Remove ORs (1117 and 1131).
2. Remove the pumps by turning them 45° clockwise and pulling backwards.
3. Remove air regulators (pos. 271), now, by turning them anticlockwise and pulling downwards.
4. Remove spring (pos. 206) and valve (pos. 245). With the extracotr provided, remove OR (pos. 1126).
5. Unscrew the two knobs (pos. 8B) in order to separate cover (pos. 202) and pump body(pos. 39).
6. Hit the pump body in order to remove its gears (pos. 38 and 38A). With the extractor, remove OR (pos. 1178).

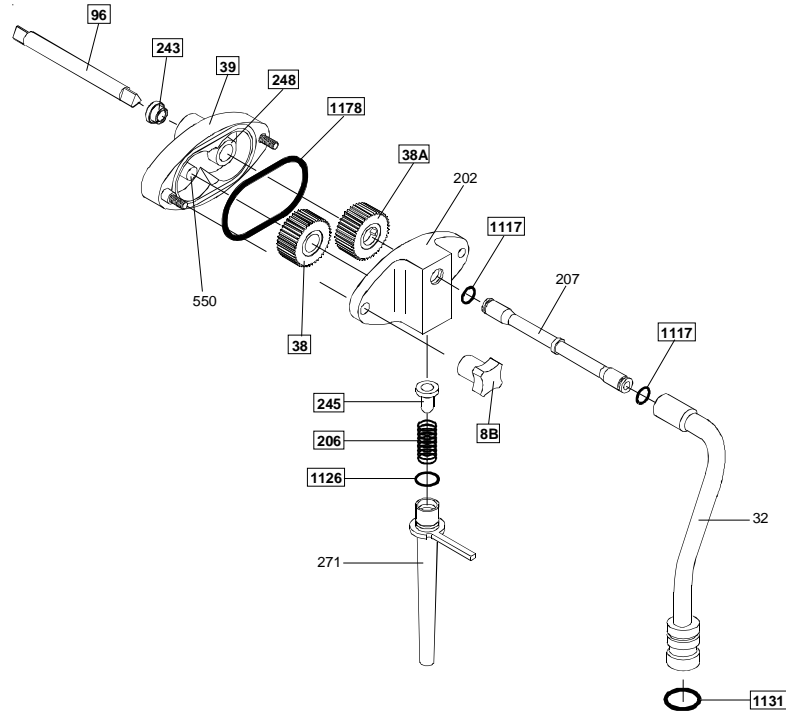

5.4 GRAVITY FED MACHINES - DISASSEMBLING FEEDING NEEDLE



To disassemble the feeding needle

- remove its slider (pos. 52)
- take the feeding needle out of the tank
- remove OR from the needle (pos. 1131)

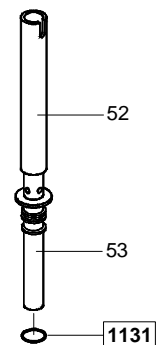

5.5 DISASSEMBLING THE TANK MIXER



After taking out the pump, also remove the mixer (pos. 162) by pulling it upwards.

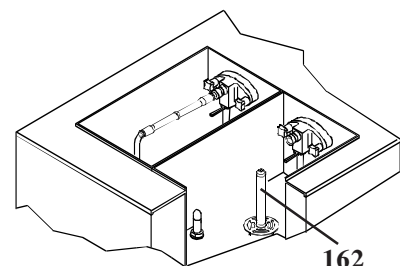

5.6 DISASSEMBLING FRONT LID

CAUTION

Before disassembling the front lid, make sure that tanks and cylinders are completely drained.

1. Remove the two retaining knobs (pos. 8A) and pull the door assembly towards you sliding it off the two front panel studs.
2. Pull the dispensing handle (pos. 5) so the pistons (pos. 30 and 302) raise in their housing.
3. Remove the pivot pin o-ring (pos. 1285) and the pivot pin (pos. 6) out releasing the dispensing handle (pos. 5)
4. Using the dispensing handle pull the piston (pos. 30 and 302) out completely.
5. Using the o-ring extractor, remove the o-rings (pos. 1153, 303 and 1188).

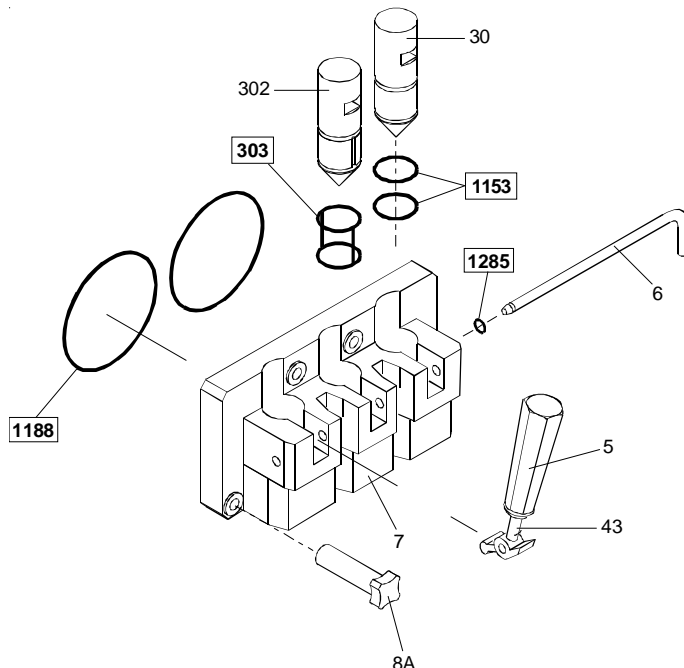

5.7 PUMP FED MACHINES - DISASSEMBLING BEATER

- 1- Pull the beater out of the cylinder.
- 2- Slide the beater seal (pos. 28) out of the beater shaft.
- 3- Pull out and remove the end pusher (pos. 25P) and the idler (pos. 24).
- 4- Remove the 3 beater blades (pos. 430).

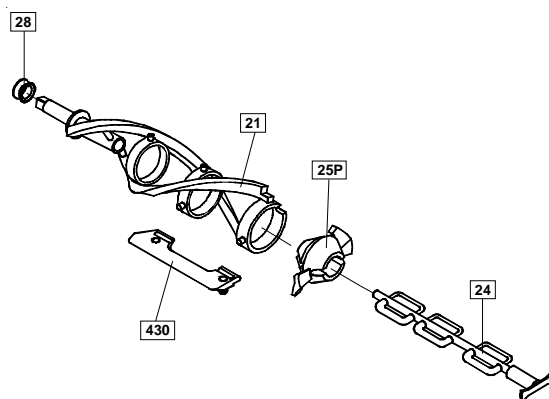

5.8 GRAVITY FED MACHINE - DISASSEMBLING BEATER

- 1- Pull the beater out of the cylinder.
- 2- Slide the beater seal (pos. 28) out of the beater shaft.
- 3- Pull the idler (pos. 24) slightly to the front of the beater until the groove in the shaft of the idler lines up with the slot on the beater frame. Pull the idler out.

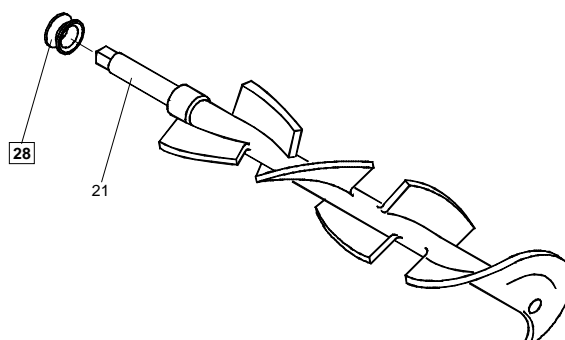

5.9 WASHING AND SANITIZING COMPONENTS

CAUTION

For the use of sanitizers, instructions on labels are to be followed.



1. Fill a clean sink with detergent and hot water (122-140°F).
2. Wash the disassembled parts with the solution and scrub them thoroughly with the brushes provided with the machine. As you proceed, rinse with hot water. Make sure lubricant and mix film are removed from parts.
3. Mix the sanitizer into the clean pail with at least two gallons of warm water. Mix the sanitizer and water to make a 100 PPM concentration of sanitizer solution. Using the spatula, stir the solution until the sanitizer is completely dissolved.
4. Place the parts in the sanitizing solution. Leave them there at least 1 minute.
5. Place the components on a clean tray to air-dry.
6. Return to the machine with a small amount of sanitizer.
7. Dip a brush into the sanitizer and thoroughly brush the freezing cylinder
8. Dip a brush into the sanitizer and thoroughly brush clean the mix inlet hole and the pump drive hub opening in the rear mix tank.
9. Spray the back of cylinder and the tank walls with sanitizer.

Repeat step 7, 8, and 9 several times

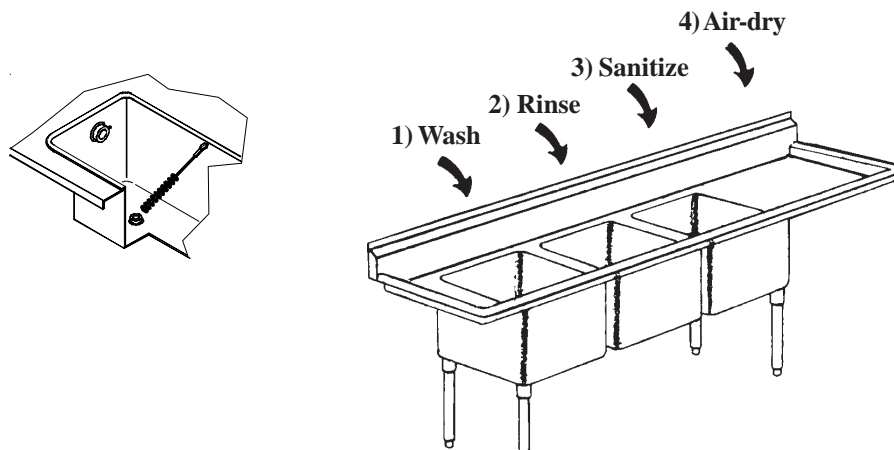

5.10 PUMP FED MACHINES - REASSEMBLING THE MIX PUMP

1. Lubricate and place the o-ring (pos. 1117) back on the connection tube (pos. 207).
2. Lubricate and place the o-rings (pos. 1126 and 1131) back on the pressure pipe (pos. 32).
3. Insert the connection tube (pos. 207) assembly in the pressure pipe (pos. 32)
4. Dip the pressure pipe into a sanitizing solution.
5. Lubricate and install the pump body o-ring (pos. 1178) and the two o-rings (pos. 1266)
6. Lubricate the sides as well as the center of the pump gears (pos. 38 and 38A) with a thin film of lubricant and insert them into the pump body (pos. 39). **Do not lubricate the teeth of the pump gears.**
7. Lubricate and place the o-ring (pos. 1412) on the feeding tube (pos. 271).
8. Hold the pump cover (pos. 202) upside down and insert the back flow valve (pos. 245) and spring (pos. 206) in their pump cover housing.
9. Insert the feeding tube (pos. 271) in the pump cover: push and turn it clockwise.
10. Assemble the pump cover (pos. 202) with the feeding tube downwards onto the pump body and turn the two knobs (pos. 8) tightly; install the mix pump in the tank with the locking pin hook on the right, turning the pump anticlockwise until it locks onto the tank locking pin.

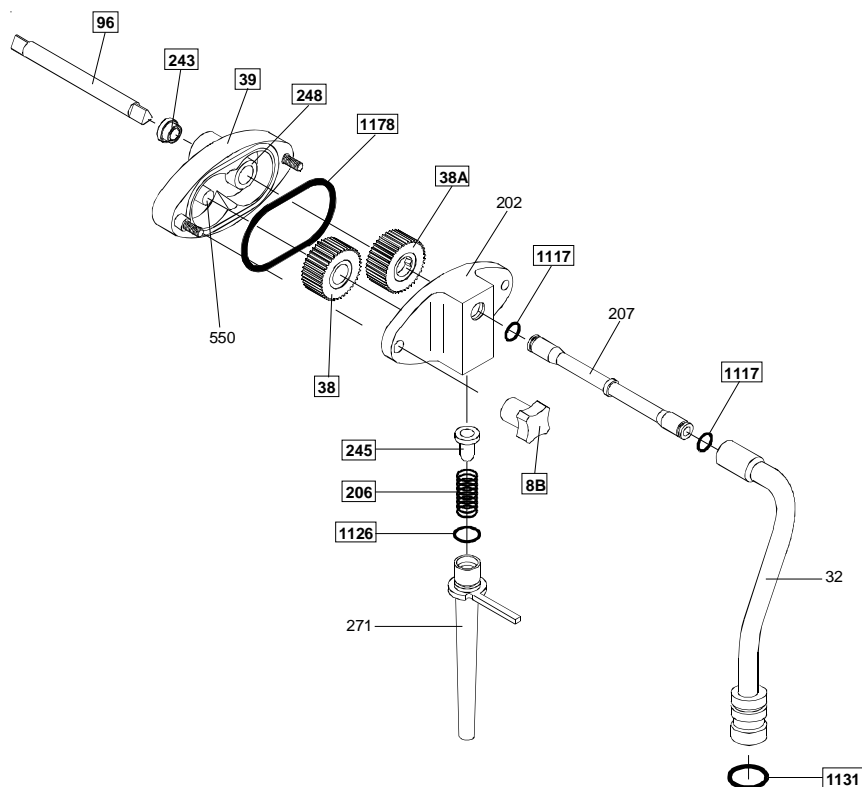

5.11 GRAVITY FED MACHINES - REASSEMBLING FEEDING NEEDLE

- 1- Lubricate the o-ring (pos. 1131)
- 2- Reassemble the feeding needle
- 3- Place the feeding needle in the sanitizing solution.

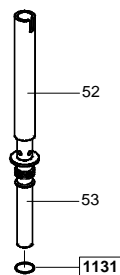



5.12 PUMP FED MACHINES - REASSEMBLING BEATER

- 1- Insert the 3 beater blades (#430) onto the beater frame. Carpigiani suggests to replace the blades each 6 months (please see the tune-up kit card).
- 2- Insert the end pusher (#25P) onto the beater frame.
- 3- Insert the end of the idler shaft (#24) in the rear housing of the beater, through the end pusher. Push the idler into position.
- 4- Lubricate the sides of the beater seal (#28) and slide it onto the beater shaft.
- 5- Insert the beater assembly into the cylinder. Push it while turning it clockwise until it engages in its rear hub, otherwise the dispensing head cannot be fastened properly, mix can flow out and serious damage may occur.

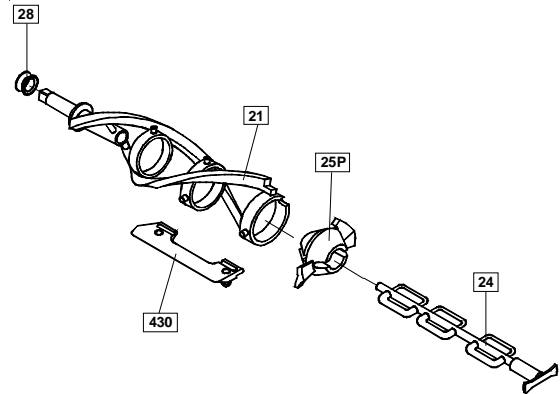

5.13 GRAVITY FED MACHINES - REASSEMBLING BEATER



- 1- Lubricate the sides of the beater seal (pos. 28) and slide it onto the beater shaft.
- 2- Insert the beater assembly into the cylinder. Push it while turning it clockwise until it engages in its rear hub, otherwise the dispensing head cannot be fastened properly, mix can flow out and serious damage may occur.

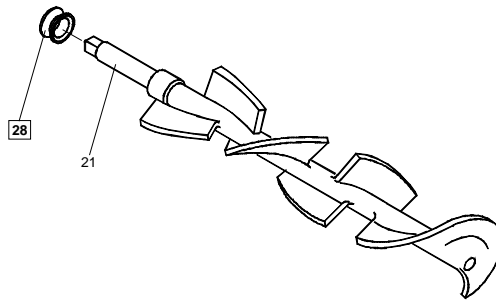

5.14 REASSEMBLING FRONT LID



1. Lubricate and slide the piston o-rings (pos. 1153 and 303) into their seats.
2. Insert the pistons (pos. 30 and 302), pointed end down, in the dispensing head (pos. 7) making sure that the piston square notch lines up with the rectangular opening on the spigot front.
3. Position the dispensing handle (pos. 5) on the lid (pos. 7) and insert the pivot pin (pos. 6) in its housing through the handle lever hole. Lubricate and insert the pivot pin o-ring (pos. 1285). Lubricate and slide the large front lid o-ring (pos. 1188) into its seat.
4. Insert the front lid assembly onto the two front panel studs and fasten it with the two knobs (pos. 8A) hand tight.

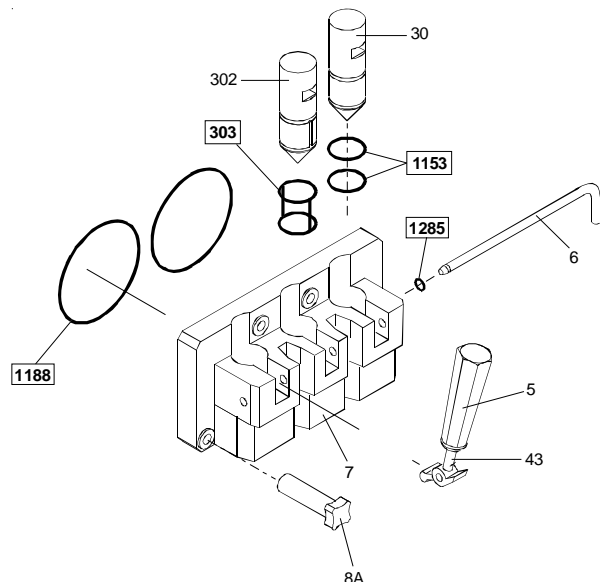

5.15 SANITIZING THE WHOLE MACHINE

The machine must be sanitized before mix is poured in. Proceed as follows:

1. Fill the tanks to the maximum level with sanitizer (Mix the sanitizer and water to make a 100 PPM concentration of sanitizer solution. Using the spatula, stir the solution until the sanitizer is completely dissolved) and allow to drain into the cylinders.
2. Using the brush, clean the mix level sensors, the entire surface of tanks and the surface of the mix pumps.
3. Select CLEANOUT function and let the beater run about 10 seconds. Press the STOP button. Cylinders and pumps are now filled with the sanitizing solution.
4. Return to the machine with a small amount of sanitizer solution in a pail.
5. Dip the door spout brush in the pail of sanitizer and brush clean the dispensing spout. Repeat the operation twice.
6. Wipe the exterior of machine with clean sanitized towel. Repeat the operation twice.
7. Wait for at least 5 minutes before proceeding with the next instructions.
8. Place an empty pail under the front lid and pull the handle
9. Allow all of the sanitizer to drain. If the sanitizing solution does not flow out completely, keep the spigot open and select CLEANOUT function, let the beater running 5 seconds so that the last solution residues flow out, then push STOP.



CAUTION

Do not keep the beater running more than the time strictly needed to complete washing and saniting since the beater would wear out without lubricating action of mix fats.



5.16 MIX PRIMING

Prime Hopper :

- Retrieve 1 bag of mix from the walk-in refrigerator.
- With the draw handle open, pour one bag of mix into the hopper allowing it to drain into the freezing cylinder.
- When only full strength mix (not mix and sanitizer) is flowing from the draw spout, close the draw handle.



By pump fed machines - Connect the mix pressure pipe:

- When the mix stops bubbling from the bottom of the hopper, take the mix pressure pipe from the sanitizing solution and insert it in its position in the bottom of the hopper. Make sure your hands are clean and sanitized.
- Turn the pressure pipe clockwise towards the pump and connect the tube to the pump.
- Select production function to start the Automatic freezing operation.
- Replace the hopper cover.

By gravity fed machines - Connect feeding needle:

- When the mix stops bubbling from the bottom of the hopper, take the mix feeding needle from the sanitizing solution and insert it in its position in the bottom of the hopper and adjust the slider to the smallest diameter hole. Make sure your hands are clean and sanitized.
- Select production function to start the Automatic freezing operation.
- Replace the hopper cover.

6. MAINTENANCE

6.1 SERVICING TYPOLOGY

ATTENTION

Any servicing operation requiring the opening of machine panels must be carried out with machine set to stop and disconnected from main switch
 Cleaning and lubricating moving parts is forbidden
 Repairs of electrical and freezing plants must be carried out by skilled engineers



Operations necessary to proper machine running are such that most of servicing is completed during the machine production cycle.

Servicing operations, such as cleaning of parts in contact with the product, replacing of stuffing boxes, disassembling of beater assembly are to be carried out at the end of a working day, so as to speed up servicing operations required.

Herebelow you can find a list of routine servicing operations:

- Cleanout and replacement of stuffing box

Should you ever find that some product drips from dripping tubes on machine front, it means that stuffing boxes (pos. 28) have lost their tightness; when disassembling the beater, it is consequently necessary to check them and, according to the machine working period, to replace and alternate them with the stuffing boxes included in the machine accessory kit.

If the stuffing boxes show no defects, they can be used again after washing them, when at room temperature they have regained their original shape.

Replace stuffing boxes as follows:

Draw the beater assembly out.

Remove stuffing box from its seat

Lubricate the new stuffing box and mount it

Before putting the stuffing box away, clean and lubricate it so as to reach its elasticity again.

WARNING

If you continue to work after noting traces of product in the drawer, you further accentuate the leakage of the stuffing box; this can lead to a malfunction of the machine serious enough to halt production.

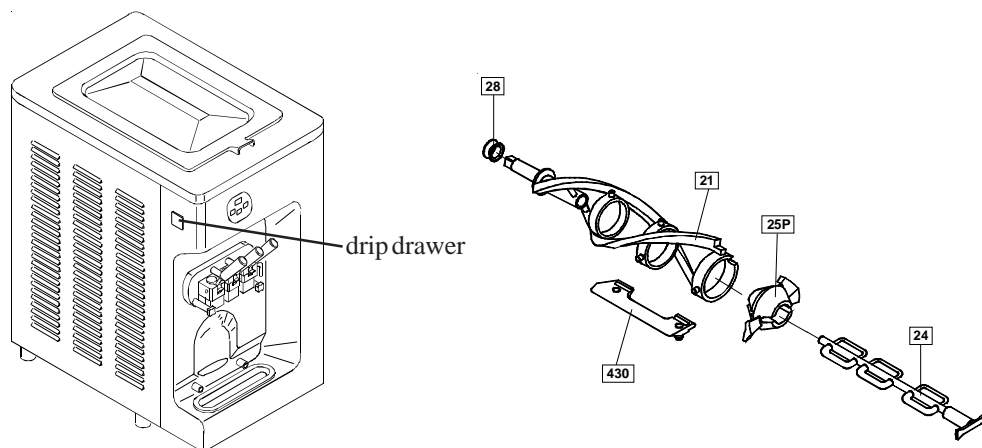

WARNING

Like all moving parts, the complete beater is also subject to wear and tear. For this reason, we recommend checking the amount of wear to parts in direct contact with one another (beater/beater idler and beater/cylinder walls) on a regular basis during scheduled cleaning operations and in any case, every six months of machine operation.

In particular, make sure that the wear on the bushing on the beater idler is no more than 2 mm, as indicated by the marking on the bushing itself. If there is more than 2 mm wear, it is necessary to replace the beater idler.



- **Cleanout of beater assembly, cleanout of pump or feeding needle, cleanout and sanitization of the all machine**
To be carried out every day, according to procedures described in section 5 of this manual.
- **Cleanout of panels**
To be carried out daily with neutral soap, seeing to it that cleansing solution never reaches beater assembly at its inside.



WARNING

Never use abrasive sponges to clean machine and its parts, as it might scratch their surfaces.

6.2 WATERCOOLING

By machines with watercooled condenser, water must be drained from condenser at the end of selling season in order to avoid troubles in the event that the machine is stored in rooms where temperature may fall under 32°F.

After closing water inlet pipe, withdraw drain pipe from its seat and let water flow out from circuit.

6.3 AIRCOOLING

Clean condenser, periodically, so as to remove dust, paper and what can prevent air from circulating.

For cleanout, use a brush with long bristles or a bolt of compressed air.

ATTENTION

When using compressed air, put on personal protections in order to avoid accidents; put on protective glasses



NEVER USE SHARP METAL OBJECTS TO CARRY OUT THIS OPERATION. GOOD WORKING OF A FREEZING PLANT MOSTLY DEPENDS ON CLEANING OF CONDENSER.



6.4 TABLE OF SPARE PARTS EQUIPMENT

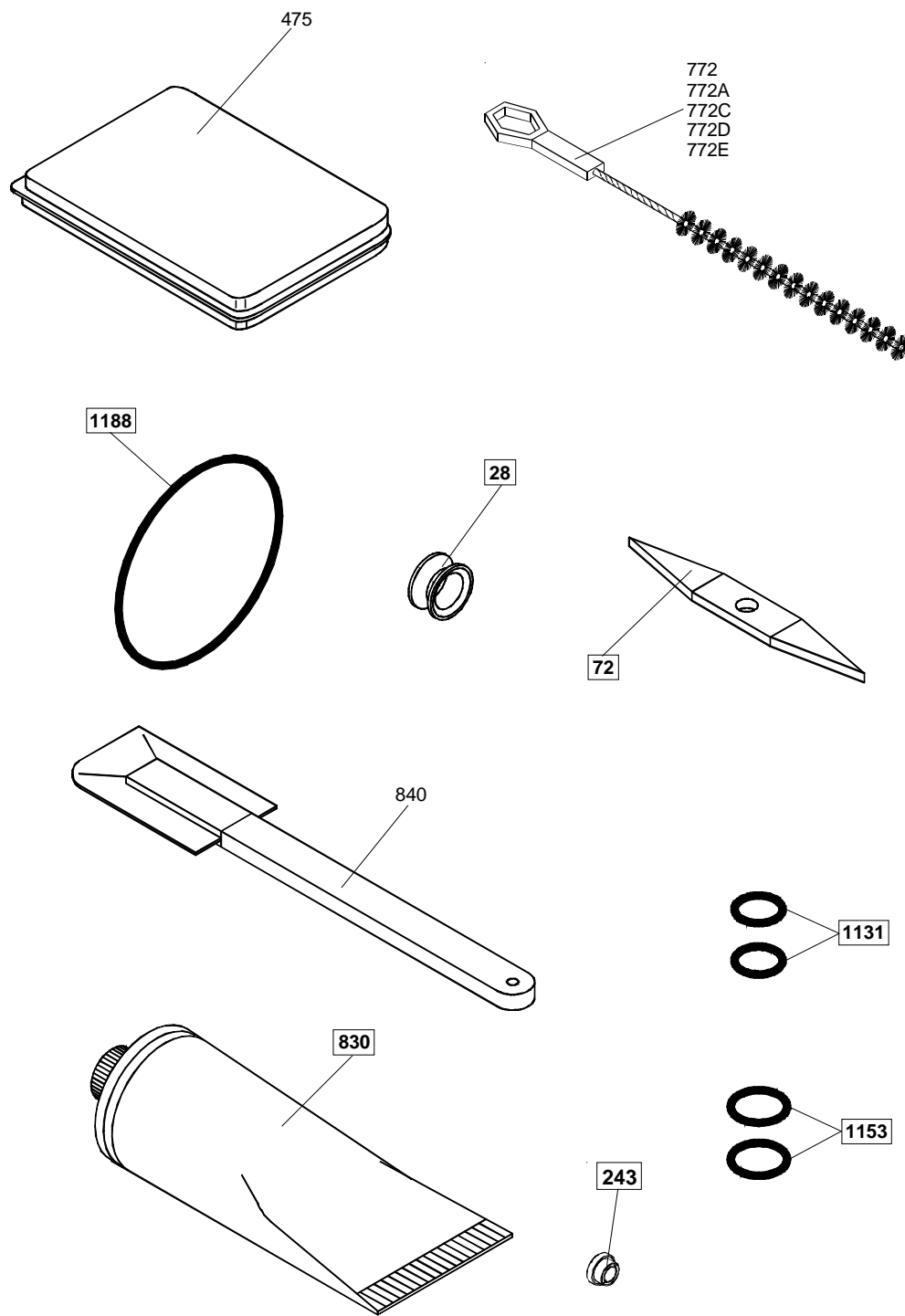

Pos.	Description
28	Beater stuffing box
72	O ring extractor
243	Stuffing box
475	Accessories
772	SwabD8x250
772A	SwabD15x350
772C	SwabD40x400

Pos.	Description
772D	SwabD30x640
772E	SwabD85x145x390
830	Food-grade lubricant tube
840	Cleaning spatula
1131	Gasket OR
1153	Gasket OR
1188	Gasket OR

7 TROUBLESHOOT GUIDE

IRREGULARITY	CAUSE	PROCEDURE TO FOLLOW
Compressor starts and then stops after a few seconds.	1.If machine is watercooled: water is not circulating. 2. If machine is aircooled: air is not circulating.	1.Open water inlet cock and check that pipe is not squashed nor bent. 2.Check that machine clearance is at least 80 mm from wall. 2.Call for service if necessary
Mix or ice cream come out above or below piston though it is closed.	1.Piston without OR or OR is worn-out.	1.Stop the machine and insert or replace it with a new one if worn-out.
Mix coming out of drip tube	1.Stuffing box missing or worn-out.	1.Stop the machine and install it if missing. If worn-out, replace it with a new one.
Piston hard to operate.	1.Dry sugar on piston.	1.Stop the machine and wash thoroughly and grease piston and OR with edible fat.
Ice cream comes out from front lid .	1.OR missing or not properly fit. 2.Front lid knobs not tightened evenly.	1.Stop the machine and check and put remedy. 2.Stop machine. loosen and tighten them again.
Low ice cream overrun	1."R" pump not properly adjusted	1.Change regulator (Pos. 271).
Drip drawer shows mix drops	1. Pump stuffing box not properly installed or damaged	1. Stop the machine, disassemble pumps and check their stuffing boxes are o.k.