



PARTS & SERVICE MANUAL

Digital Countertop Series 2500



REV: 11.2.10

Lincoln Foodservice Products, LLC
1111 North Hadley Road
Fort Wayne, Indiana 46804
Telephone: 260.459.8200
Fax: 888.790.8193
Technical Support: 800.678.9511
lincolnfp.com

MODEL NUMBER KEY

EXAMPLE: 2501-000-U-0001620

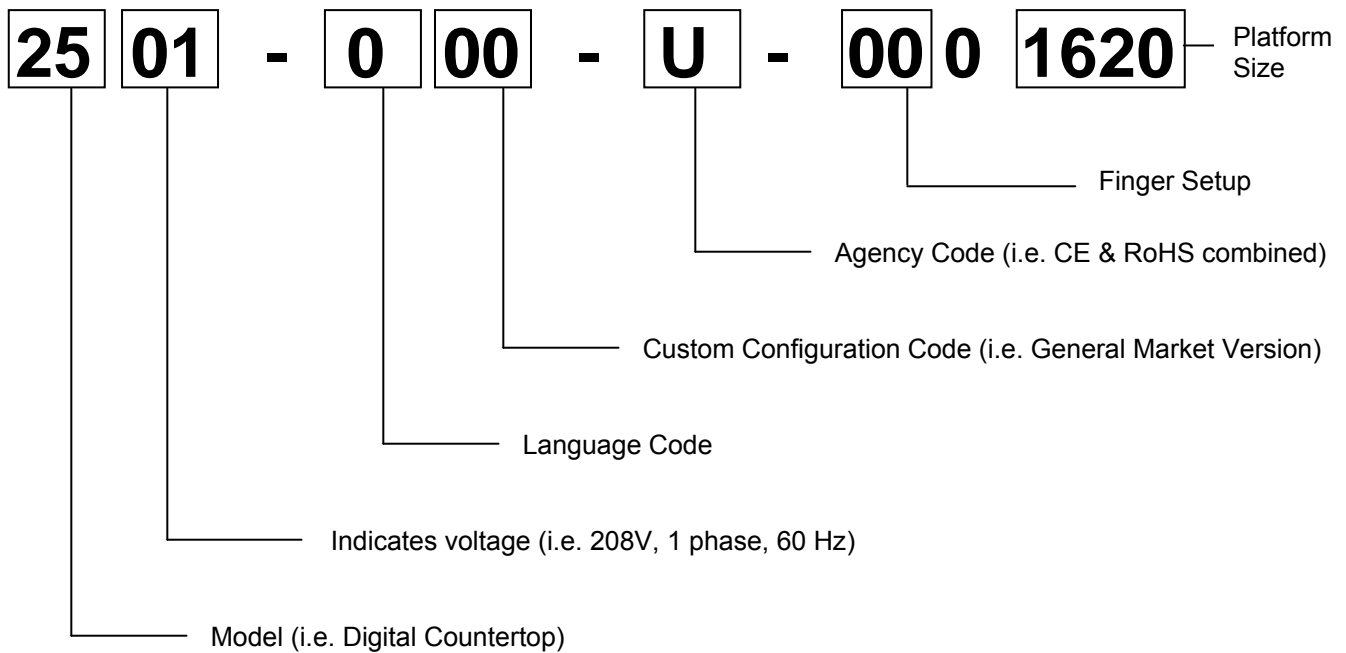

CODE	LANGUAGE	COUNTRY	CODE	LANGUAGE	COUNTRY
0	English	Dom. & Int. Default	N	Finnish	Finland
B	French	France/Luxembourg	O	Restricted	---
C	German	Germany	P	Norwegian	Norway
D	Italian	Italy	Q	English	Japan
E	Spanish	Spain	R	Swedish	Sweden
F	English	UK/India/Africa/Hungary	S	English	Australia
G	Spanish	Mexico/Latin America	T	Mandarin	China
H	Portuguese	Portugal	U	Restricted	---
I	Not Used	---	V	English	Pacific Rim/Korea
J	Danish	Denmark	W	English	Middle East
K	Dutch & French	Belgium	X	Not Used	---
L	Dutch	Netherlands	Y	Not Used	---
M	Greek	Greece	Z	Not Used	---

AGENCY CODE TABLE

CODE	AGENCY
N	No Agency
E	CE & RoHS compliance combined
U	US & Canada compliance only
A	Advantage style oven to be phased-out
B	Australia AGA

DIGITAL DISPLAY CONTROL PANEL

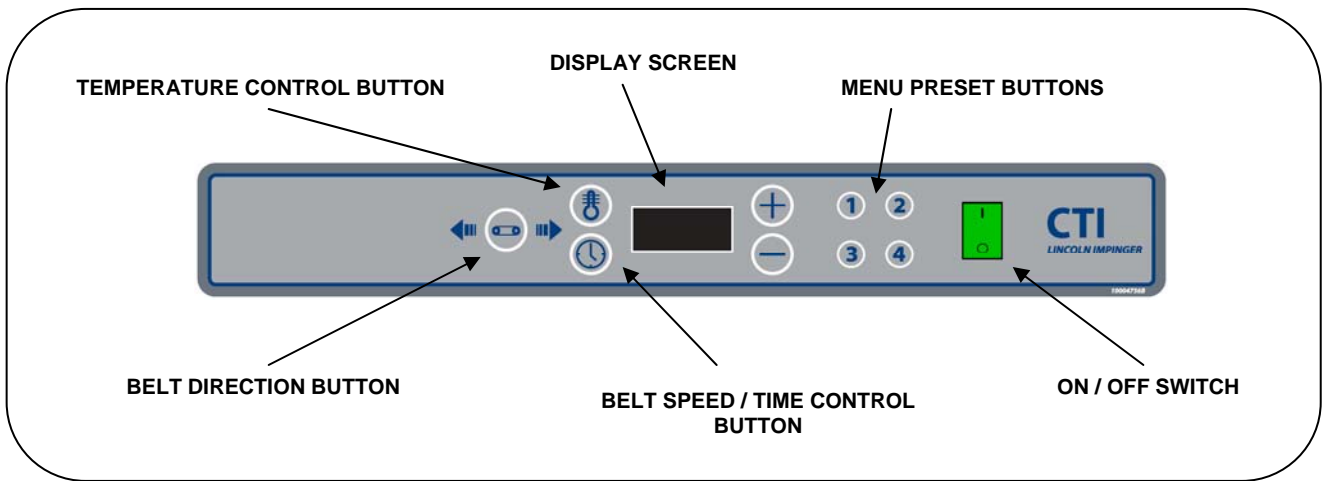

OPERATING INSTRUCTIONS



WARNING:

Do not work around conveyor belt with long hair, loose clothing, or dangling jewelry. Getting caught in the conveyor belt could result in serious injury!

Prior to operating your new countertop oven, it is important to understand the available options. Following is a chart designed to better illustrate these options.

CONTROLS	DESCRIPTION
Belt Speed / Time Control	Belt speed refers to how quickly the food item travels through the oven. This is shown on the display board as a unit of measure (fast to slow) between 0:30 seconds and 15:00 minutes.
Temperature Control	The countertop oven will allow you to determine the temperature setting of the oven. You have the ability to program your oven so that more (or less) heat will emanate from the unit. This is shown on the display board as a unit of measure between 90°F – 600°F.
Belt Direction	The countertop oven will allow you to change the direction in which the conveyor belt moves. Pressing the “Belt Direction Button” will change the direction of travel between left-to-right and right-to-left options.

POWER-UP THE OVEN

1. Turn the “On/Off Switch” to the “on” position. The oven will now run according to the previously programmed settings. Allow the oven to preheat for approximately 30 minutes.



ON / OFF SWITCH

CHANGE BELT DIRECTION

1. Press the “Belt Direction Button” to change the direction in which the conveyor belt travels.

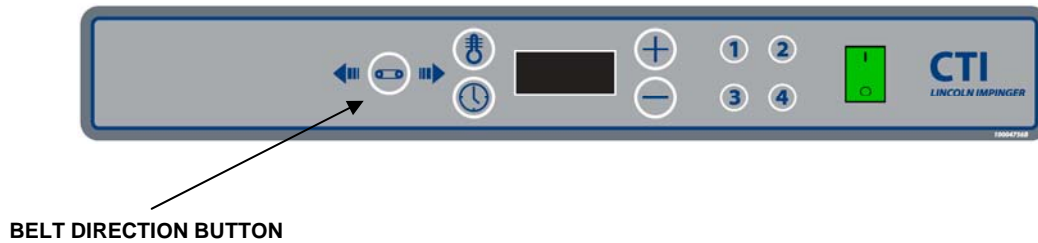

PROGRAMMING THE FOUR MENU PRESET BUTTONS

1. Press and hold the desired menu button (1-4) for approximately 5 seconds. The display screen will flash the temperature setpoint. Press the (+) or (-) button to reach the desired temperature.
NOTE: All menu presets come with default settings of “Pizza” at 550°F / 6:00.

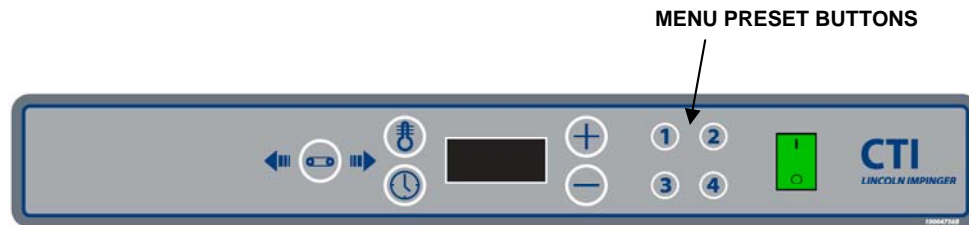

2. Press and release the menu button again to reach the time/belt speed setpoint. The display will flash the time/belt speed setpoint. Press the (+) or (-) button to reach the desired time/belt speed.
3. Press and release the menu button again to reach the menu item name. The display will flash a menu item name. Press the (+) or (-) button to locate the desired name. Once the desired name has been selected, press and release the menu button again to activate the menu setting.
NOTE: The following menu items have been preset into the software package of this oven.

- | | | |
|---------------|------------|----------|
| • Pizza | • Sandwich | • Wrap |
| • Wings | • Chicken | • Menu 1 |
| • Breakfast | • Snack | • Menu 2 |
| • Breadsticks | • Snack | • Menu 3 |
| • Thin Pizza | • Dinner | • Menu 4 |

PROGRAMMING THE MANUAL MODE

1. Press and hold the Time and Temperature buttons for approximately 5 seconds to enter manual mode. Press the Time button to allow for changes in time. Press the (+) or (-) button to reach the desired time.

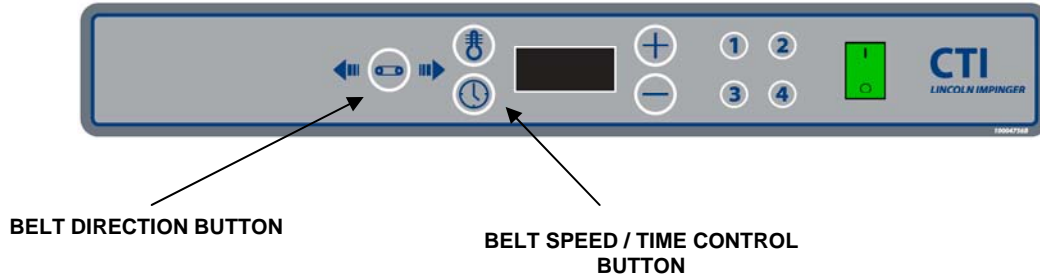

2. Press and release the Temperature button to allow for changes to temperature. Press the (+) or (-) button to reach the desired temperature. Press and release the Temperature button again to leave manual mode and activate the manual settings.

TEMPERATURE CONTROL BUTTON



SHUTDOWN

1. Push the "On/Off Switch" to the "off" position.
2. As each countertop oven is equipped with a 30-minute cool-down timer, the fan motor will continue to run for 30 minutes after the unit has been turned off. The fan motor will automatically stop at the end of the 30-minute cool-down period.



ON / OFF SWITCH

ACCESSING SUBSET MENU OPTIONS

There are three settings that can be accessed by an authorized technician; the temperature calibration setting, temperature display (°F or °C) and the conveyor belt direction.

SUBSET MENU INSTRUCTIONS

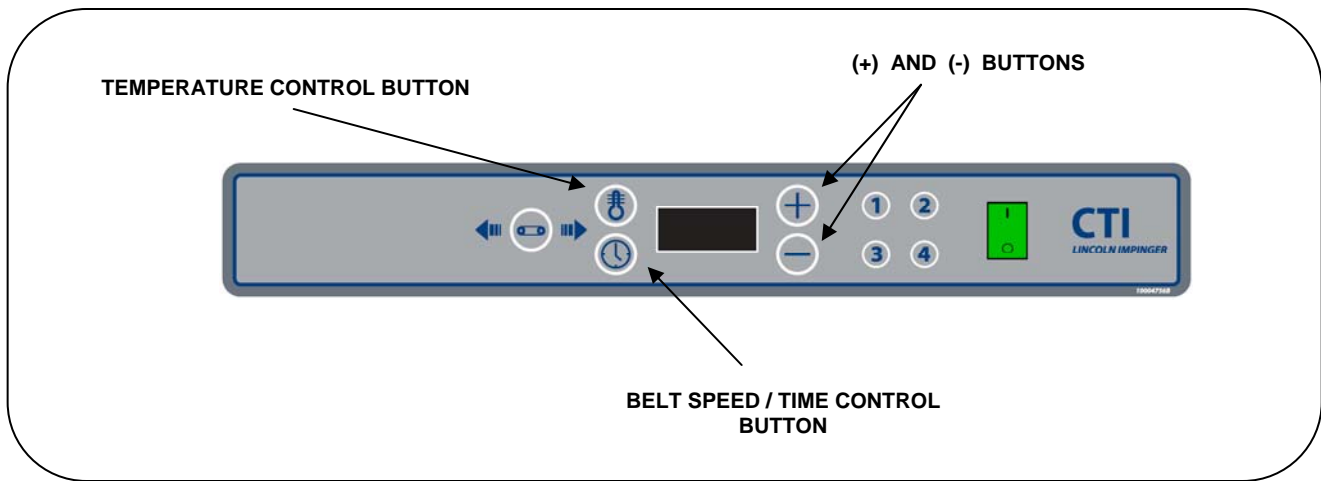

STEP ONE

To access the subset menu, press and hold the (+) and (-) buttons for approximately 5 seconds. The calibration value will be displayed. If a change to the calibration value is desired, press either the (+) or (-) buttons until the desired value is reached. If no change to calibration value is needed, press the “Temperature Control” button to reach the temperature display setting.

STEP TWO

Complete step one. To change the temperature display setting between °F and °C, simply press the (+) or (-) button until the desired setting is displayed. If no change to the temperature display setting is needed, press the “Belt Speed / Time Control” button to reach the conveyor belt direction setting.

STEP THREE

Complete steps one and two. To change the conveyor belt direction, press the (+) or (-) button until the desired belt direction setting is reached. Once reached, press the “Belt Speed / Time Control” button to save the changes and exit the subset menu.

SEQUENCE OF OPERATION

Power Supply	<p>Electrical Power is supplied to the oven by a three conductor cord set. Black conductor is HOT. White conductor is HOT. Green conductor is ground. Line voltage is supplied through the fuses(F1, F2)and line one(L1) through the manual resettable control box high limit(T1) to the ON/OFF switch, the Cooling Fan Thermostat(T2), the Cool Down Timer(TD), and to the Main Fan Relay(R2).</p>
Control Box Auto Cool Down	<p>The cooling fan thermostat is connected to the axial fan that cools the control box. Line two (L2) connects to the other side of the Control Box Cooling Fan motor bypassing the ON/OFF switch. The thermostat closes at 120°F cycling the fan keeping the control box below 120°F</p>
Main Fan Circuit	<p>Upon activating the ON/OFF switch, power is supplied to the Cool Down Timer (TD) through the timer (TD) to the Main Fan Relay (R2) through the relay (R2) to power the Main Fan (M1).</p>
Heating Circuit	<p>When the heating contactor then closes, supplying line voltage to the SSR for the heater. Line voltage is then supplied to the element through the SSR as needed to maintain set point temperature.</p>
Oven Control	<p>Upon closing the ON/OFF switch, the transformer is supplied line voltage and then supplies 24 VAC to the control board and controls the conveyor motor. The control reads the thermocouple and cycles the SSR to the heater to maintain set point temperature. The control board also reads the input from the key pad to make adjustments for cook time and temperature.</p>
Conveyor Drive	<p>The control board transformer's (XR) secondary supplies 24 VAC to the control board (CNTR). The conveyor control converts AC to DC and DC power is supplied to the conveyor motor (M3). 2-29 VDC is supplied to the motor (M3) through 4 wires (2 sets A+ A- & B+ B-).</p>

SCHEMATIC DIAGRAM

2501-000, 2501-001, 2501-002, 2501-003, 2501-008, 2501-009, 2502-000, 2502-001, 2502-002, 2510-000

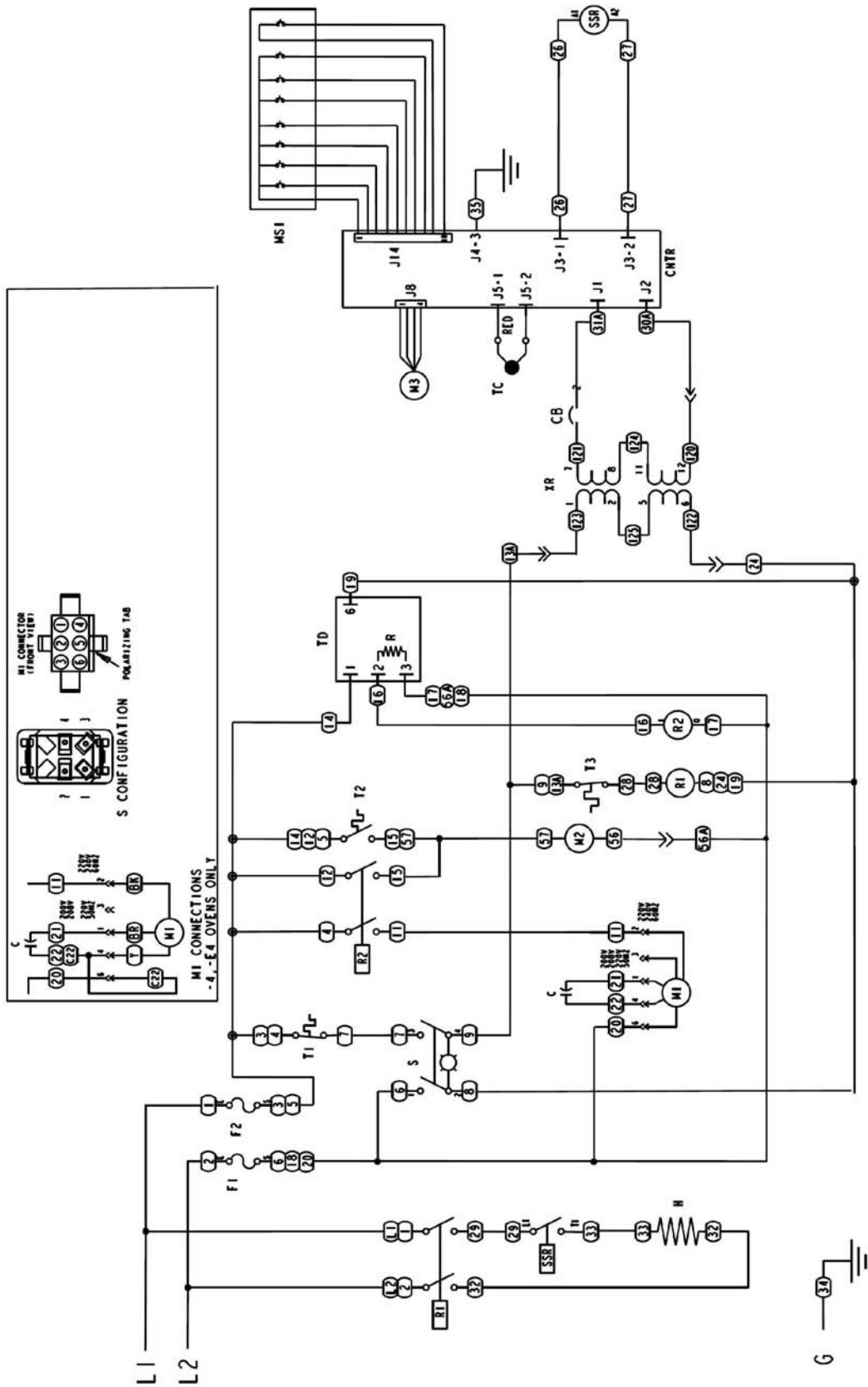

Lincoln
Foodservice Products, Inc.
FORT WAYNE, INDIANA
IMPINGER COUNTERTOP OVEN

- C - CAPACITOR
- CB - CIRCUIT BREAKER
- CNTR - CONTROLLER
- F1, F2 - FUSE
- H - HEATING ELEMENT
- MS1 - MEMBRANE SWITCH PANEL
- M1 - MOTOR, MAIN FAN
- M2 - MOTOR, COOLING FAN
- M3 - MOTOR, CONVEYOR
- R - RELAY, HEATING ELEMENT
- SSR - SOLID STATE RELAY
- S - SWITCH, MAIN
- T1 - THERMOSTAT, HI LIMIT, CONTROL
- T2 - THERMOSTAT, COOLING FAN
- T3 - THERMOSTAT, HI LIMIT, OVEN
- TC - THERMOCOUPLE, TYPE J
- XR - TRANSFORMER
- (XX) - WIRE NUMBERS

20000038C

SCHEMATIC DIAGRAM
2504-000, 2504-001, 2514-000

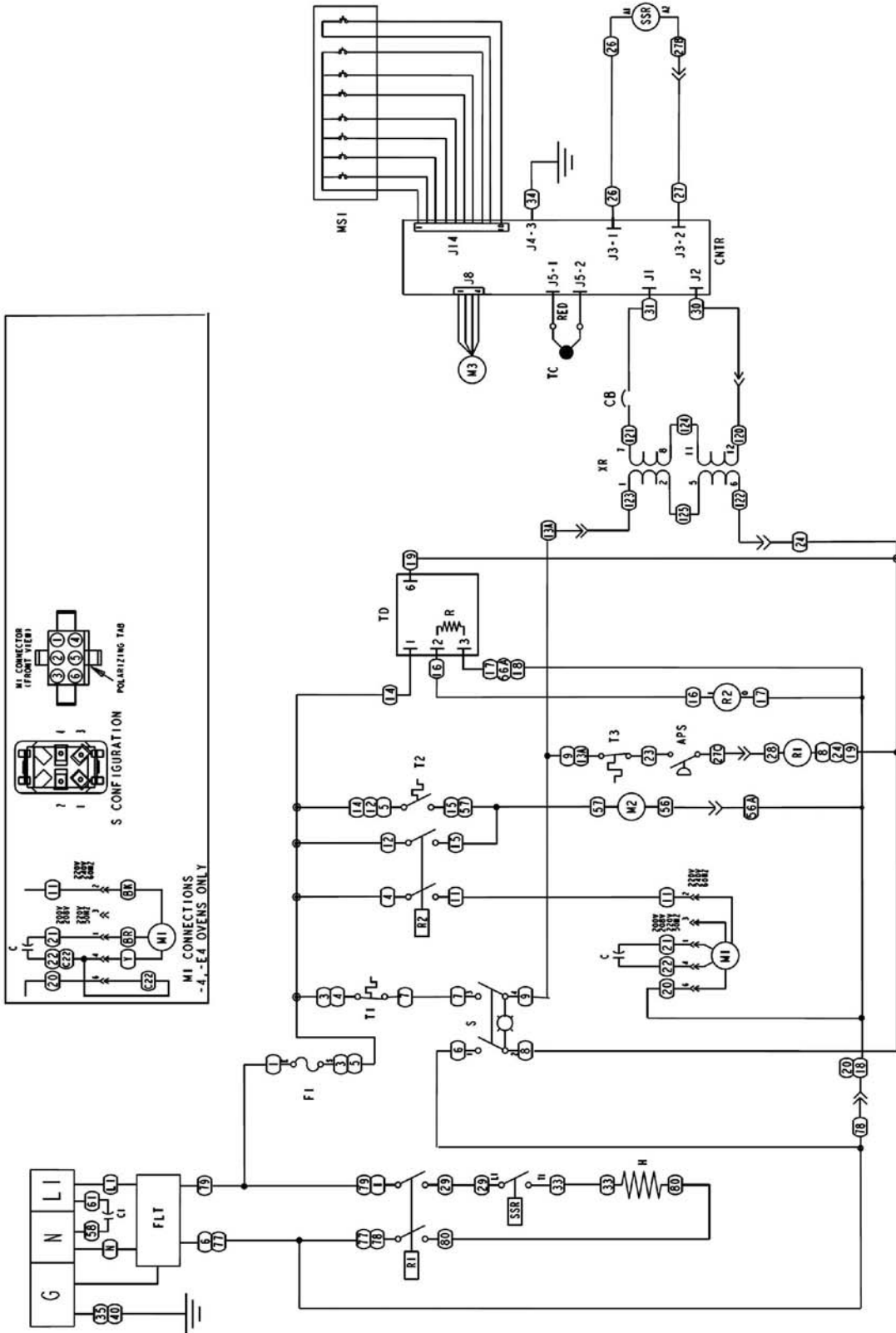

Lincoln
Foodservice Products, Inc.
FORT WAYNE, INDIANA
IMPINGER COUNTERTOP OVEN

20000076B

- APS - AIR PRESSURE SWITCH
- C - CAPACITOR
- CI - EMI CAPACITOR ASSEMBLY
- CB - CIRCUIT BREAKER
- CNTR - CONTROLLER
- F1 - FUSE, MOTOR & CONTROLS, 5A
- H - HEATING ELEMENT
- MS1 - MEMBRANE SWITCH PANEL
- M1 - MOTOR, MAIN FAN
- M2 - MOTOR, COOLING FAN
- M3 - MOTOR, CONVEYOR
- R1 - RELAY, HEATING ELEMENT
- R2 - RELAY, COOLDOWN
- SSR - SOLID STATE RELAY
- S - SWITCH, MAIN
- T1 - THERMOSTAT, HI LIMIT, CONTROL
- T2 - THERMOSTAT, COOLING FAN
- T3 - THERMOSTAT, HI LIMIT, OVEN
- TC - THERMOCOUPLE, TYPE J
- TD - COOL DOWN TIMER
- XR - TRANSFORMER, CONTROL
- (XX) - WIRE NUMBERS

SCHEMATIC DIAGRAM

2505-000

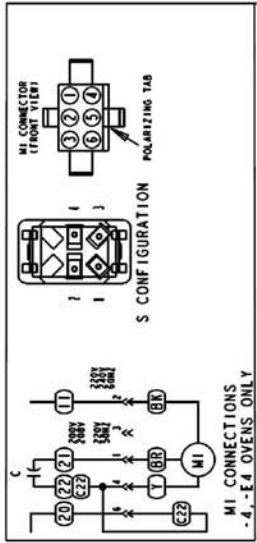
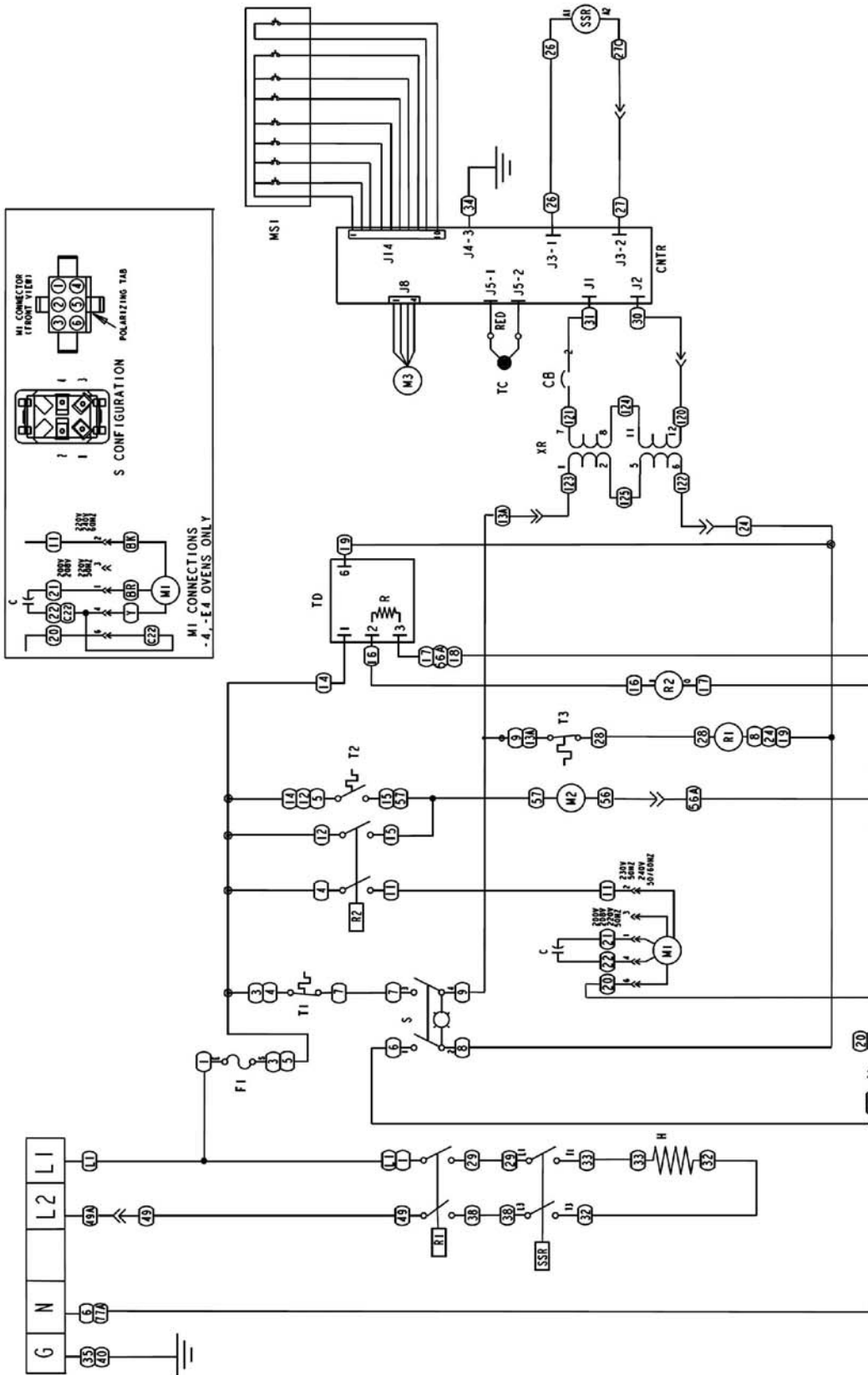

Lincoln
Foodservice Products, Inc.
FORT WAYNE, INDIANA
IMPINGER COUNTERTOP OVEN

200000758

- C - CAPACITOR
- CB - CIRCUIT BREAKER
- CNTR - CONTROLLER
- F1 - FUSE, MOTOR & CONTROLS, 5A
- H - HEATING ELEMENT
- MS1 - MEMBRANE SWITCH PANEL
- M1 - MOTOR, MAIN FAN
- M2 - MOTOR, COOLING FAN
- M3 - MOTOR, CONVEYOR
- R1 - RELAY, HEATING ELEMENT
- R2 - RELAY, COOL DOWN
- SSR - SOLID STATE RELAY
- S - SWITCH, MAIN
- T1 - THERMOSTAT, HI LIMIT, CONTROL
- T2 - THERMOSTAT, COOLING FAN
- T3 - THERMOSTAT, HI LIMIT, OVEN
- TB - TERMINAL BLOCK
- TC - THERMOCOUPLE, TYPE J
- TD - COOL DOWN TIMER
- XR - TRANSFORMER, CONTROL
- (XX) - WIRE NUMBERS

SCHEMATIC DIAGRAM

2508-000, 2509-000, 2512-000, 2512-004

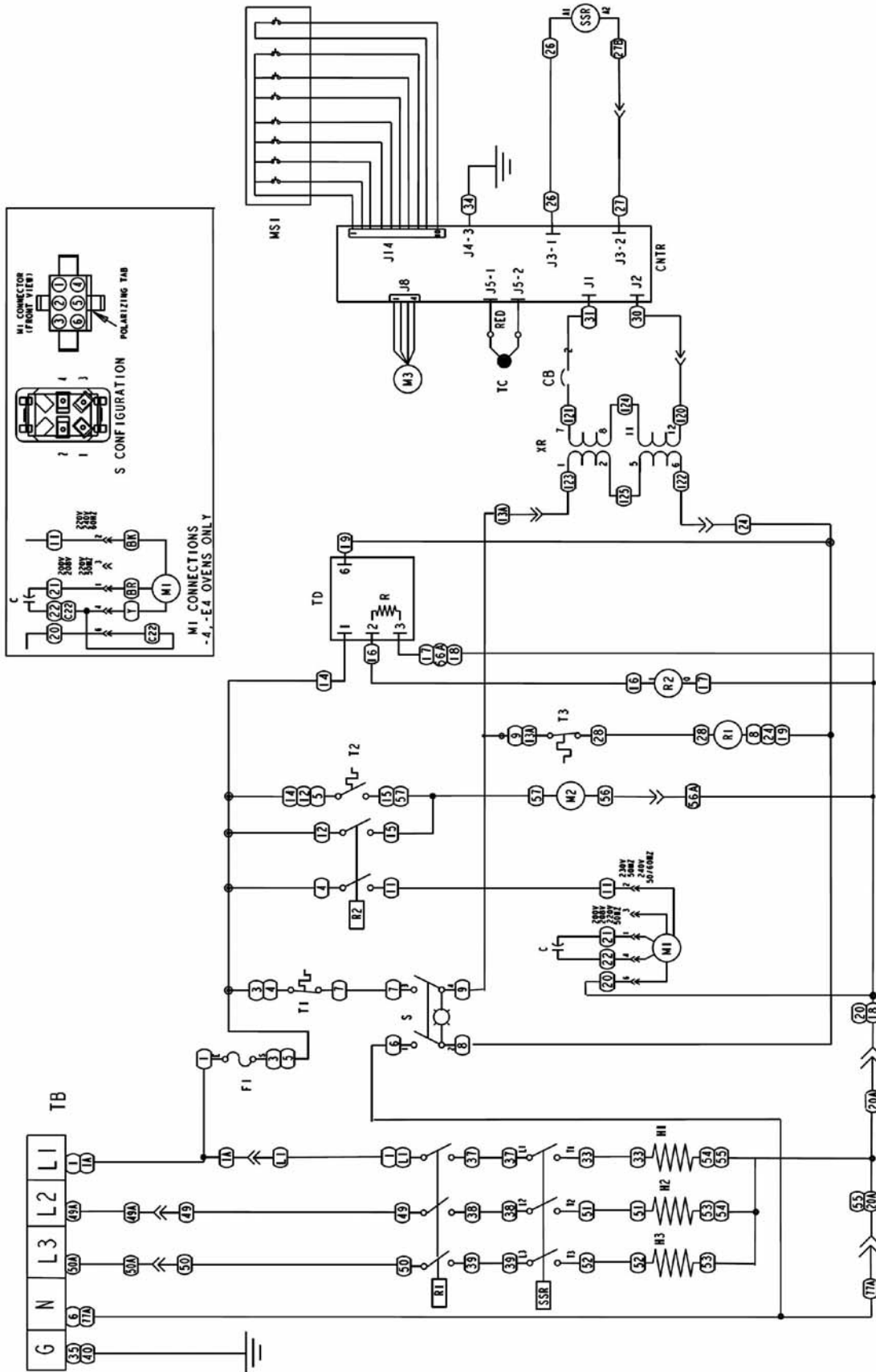

Lincoln
Foodservice Products, Inc.
FORT WAYNE, INDIANA
IMPINGER COUNTERTOP OVEN

- R2 - RELAY, COOL DOWN
- SSR - SOLID STATE RELAY
- S - SWITCH, MAIN
- T1 - THERMOSTAT, HI LIMIT, CONTROL
- T2 - THERMOSTAT, COOLING FAN
- T3 - THERMOSTAT, HI LIMIT, OVEN
- TB - TERMINAL BLOCK
- TC - THERMOCOUPLE, TYPE J
- TD - COOL DOWN TIMER
- XR - TRANSFORMER, CONTROL
- (XX) - WIRE NUMBERS

- C - CAPACITOR
- CJ - EMI CAPACITOR ASSEMBLY
- CB - CIRCUIT BREAKER
- CNTR - CONTROLLER & CONTROLS, 5A
- F1 - FUSE, HEATING ELEMENTS
- H1, H2, H3 - HEATING ELEMENTS
- MS1 - MEMBRANE SWITCH PANEL
- M1 - MOTOR, MAIN FAN
- M2 - MOTOR, COOLING FAN
- M3 - MOTOR, CONVEYOR
- R1 - RELAY, HEATING ELEMENT

20000089C

TROUBLESHOOTING GUIDE

SYMPTOM	POSSIBLE CAUSE	EVALUATION
<u>Oven fan will not run</u>	Incoming Power Supply	Check circuit breaker, reset if required. Check power plug to be sure it is firmly in receptacle. Measure incoming power, call power co. if needed.
	5 Amp Fuse and Fuse Holder	Check fuse for continuity, replace if necessary. Check fuse holder for line voltage.
	Hi-Limit Thermostat, Control Box	Terminals are normally closed and opens at 140°F(60°C), if open, reset thermostat and test oven for proper operation. If thermostat will not hold, and control box temperature is not exceeding 140°F(60°C) replace thermostat.
	Oven Power Switch	Check for 208/240VAC supply to switch. If no voltage is present, trace wiring back to fuse holder and Control Box High Limit Thermostat. Check continuity between switch terminals. Replace switch as needed.
	Oven Fan Time Delay Relay and Oven Fan Relay	Check for 208/240VAC at terminals 1 and 6 on Time Delay Relay(TD). If no voltage is present at (TD) check Main Switch. If voltage is present at TD 1 and 6 then check for 208/240 VAC output to Oven Fan Relay(R2) coil. If no voltage is present replace Time Delay Relay. If voltage is present check normally open(N.O.) contacts of relay(R2) for 208/240 VAC on both sides of the contact. If voltage is present to coil and to one side of the N.O. contact but not the other replace relay. If voltage is present then proceed.
	Main Fan Motor and Capacitor	Check for 208/240VAC supply to the motor. If no voltage is present, trace wiring back to the relay(R2). If voltage is present but motor does not turn: WITH POWER OFF: Turn fan blade to check for locked rotor. WARNING: Capacitor has a stored charge, discharge before testing. Check capacitor with multimeter. Check motor for opens, shorts or grounds.
<u>No Control Box Cooling Fan</u>	Incoming Power Supply	Check circuit breaker, reset if required. Check power plug to be sure it is firmly in receptacle. Measure incoming power, call power co. if needed.

	5 Amp Fuse and Fuse Holder	Check fuse for continuity, replace if necessary.
	Control Box Hi-Limit Thermostat	Check for continuity through the switch(T2). Terminals are normally closed and open at 140°F(60°C), if open, reset thermostat and test oven for proper operation. If thermostat will not hold, and control box temperature is not exceeding 140°F (60°C), replace thermostat.
	Oven Power Switch	Check for 208/240VAC supply to switch. If no voltage is present, trace wiring back to fuse holder and control box high limit thermostat(T2). Check continuity between switch terminals. Replace switch as needed.
	Cooling Fan Motor	Check for 208/240VAC supply to the cooling fan. If no voltage is present, trace wiring back to the relay(R2). If voltage is present and motor does not run, check for opens, shorts or grounds. WITH POWER OFF: Check for locked rotor.
<u>Cooling fan continues to run</u>	Control Box Thermostat	Check cooling fan thermostat. Thermostat closes at 120°F (49°C) and opens at 100°F(38°C). Please note: Thermostat will remain closed if control box temperature remains above 120° F (49°C).
<u>Oven will not heat</u>	Cavity High Limit Thermostat	Check High Limit Thermostat (T1) for continuity through switch. Terminals are normally closed, open at 660°F (350°C). If open, push in reset button and retest. If thermostat will not hold for maximum oven temperature, and oven is not exceeding temperature dial setting, check for proper location of capillary bulb in its bracket. If in proper location and Hi Limit continues to trip, replace Hi Limit Thermostat.
	Heating Relay	Check for 208/240VAC at coil of Heating Relay(R1) If no voltage is present at coil then check Cavity Hi Limit. If voltage is present at coil then check for 208/240 at output of relay. If no output voltage replace relay.
	Control Transformer	Check for 208/240VAC at the primary of the transformer. If voltage is present check for 24VAC on secondary side. If no 24 VAC is present check circuit breaker(CB) on transformer. If circuit

		breaker is not open and still no secondary voltage then replace transformer.																														
	Solid State Relay	Check for 24VAC at terminals A1 and A2 of the Solid State Relay(SSR). If no voltage is present then perform thermocouple checks(Thermocouple type j testing). If thermocouple checks good and still no voltage at terminals A1 and A2 then replace control board.																														
	Heating Element	If 24VAC is present at output of SSR but no heat check for 208/240 at element terminals. Check amp draws at each supply line. 208V oven is rated at 29 amps. Element is 5600W with a cold ohms reading between 8.51 to 7.36. 240V oven is rated at 24 amps. Element is 5600W with a cold ohms reading between 11.33 to 9.81. If voltage is present but no amp draw replace element. 208V Red, 240V Blue, 220V Yellow, 200V Orange, 380V Violet, 400V 1 PH Brown, 415V Green, 200V 3 PH Orange, 380V 3 PH Violet, 400V 3 PH Brown, 415V 3 PH Green																														
<u>Oven will not heat</u>	Thermocouple type j testing	WITH POWER ON AND THERMOCOUPLE ATTACHED TO THE OVEN CONTROL: Measure the DC millivolt output of the thermocouple. Refer to the chart below for readings. If these are not achieved, replace thermocouple. <table border="1"> <thead> <tr> <th>TEMP. °F (°C)</th> <th colspan="2">D.C. MILLIVOLTS (APPX)</th> </tr> </thead> <tbody> <tr> <td>200</td> <td>(93)</td> <td>3.4</td> </tr> <tr> <td>250</td> <td>(121)</td> <td>4.9</td> </tr> <tr> <td>300</td> <td>(149)</td> <td>6.5</td> </tr> <tr> <td>350</td> <td>(177)</td> <td>8.0</td> </tr> <tr> <td>400</td> <td>(204)</td> <td>9.5</td> </tr> <tr> <td>450</td> <td>(232)</td> <td>11.1</td> </tr> <tr> <td>500</td> <td>(260)</td> <td>12.6</td> </tr> <tr> <td>550</td> <td>(288)</td> <td>14.2</td> </tr> <tr> <td>600</td> <td>(316)</td> <td>15.7</td> </tr> </tbody> </table>	TEMP. °F (°C)	D.C. MILLIVOLTS (APPX)		200	(93)	3.4	250	(121)	4.9	300	(149)	6.5	350	(177)	8.0	400	(204)	9.5	450	(232)	11.1	500	(260)	12.6	550	(288)	14.2	600	(316)	15.7
TEMP. °F (°C)	D.C. MILLIVOLTS (APPX)																															
200	(93)	3.4																														
250	(121)	4.9																														
300	(149)	6.5																														
350	(177)	8.0																														
400	(204)	9.5																														
450	(232)	11.1																														
500	(260)	12.6																														
550	(288)	14.2																														
600	(316)	15.7																														
	Temperature Probe Placement	To verify the oven cavity temperature, insert your temperature meter probe tip under the conveyor and approximately 3/8"(10mm) into the bottom finger #4, 3 rd row from outside edge, 3 rd hole from the rear. This process is also used when calibrating the oven temperature. Allow temperature in oven to stabilize for 30 minutes before calibrating. Note: For best result, we recommend disconnecting the conveyor drive coupling to stop the conveyor from moving.																														
<u>Conveyor will not run</u>	Control Transformer	With the Main Fan Switch(S) on, check for 208/240VAC at the primary of the transformer. If no voltage is present, check for voltage at the																														

		<p>power switch.</p> <p>If voltage is present at the primary, check for voltage on the secondary side of transformer (24 VAC).</p> <p>If no 24 VAC present on secondary check circuit breaker (CB) on transformer. If still no secondary voltage then replace transformer</p>
	Digital Control	<p>Check for 24 VAC input to the control board at terminals J1 and J2.</p> <p>Check for 5.2 Ω between A+, A- and B+,B- on Conveyor Motor. If resistance is 5.2 Ω replace main control board.</p>
<u>Conveyor will not run</u>	Conveyor Motor	<p>The GE conveyor motor on the 2501/2502 is a stepper type. The only way to accurately test the unit at this time is by measuring the resistance between the windings. From A+ to A- and from B+ to B- should measure approximately 5.2 ohms. If the motor fails the above test, replace motor.</p>
<u>Conveyor motor runs, but intermittent or no speed control</u>	Transformer	<p>Check 208/240 input voltage to transformer. If no voltage present check the On/Off switch (S) and the Control Box Hi-Limit (T1) for continuity. Also check 5 amp fuses (F1, F2) for continuity. If voltage is present, Check for 24VAC output from transformer. If no voltage is present check circuit breaker (CB) on output of transformer, if still no secondary voltage from transformer replace transformer.</p>
	Conveyor Control	<p>Check for 2-29VDC output from conveyor control at J3-2 and J3-1. If no voltage present but 24 VAC input at J1 and J2 replace main control board.</p>
	Conveyor Motor	<p>The 4 wire conveyor motor on the 2501/2502 is a stepper type. The only way to accurately test the motor at this time is by measuring the resistance between the windings. From A+ to A- and from B+ to B- should measure approximately 5.2 ohms. If resistance is good replace digital control board. If the motor fails the above test, replace motor.</p>
<u>No Digital Display</u>	Transformer	<p>Check 208/240 input voltage to transformer. If no voltage present check the On/Off switch (S) and the Control Box Hi-Limit (T1) for continuity. Also check 5 amp fuses (F1, F2) for continuity.</p> <p>Check for 24 VAC at J1 and J2 power into the digital control.</p> <p>Check circuit breaker (CB) on output of transformer.</p> <p>If no secondary voltage from transformer replace transformer.</p> <p>If secondary voltage is present then replace main control board.</p>

REMOVAL, INSTALLATION & ADJUSTMENT GUIDE

<p>Oven Back Removal</p>	<p>WITH OVEN POWER OFF</p> <ul style="list-style-type: none"> Remove six (6) nuts and remove motor cover and vent piping. Disconnect all wiring from motor and heating element. Remove four (4) nuts holding oven back and remove oven back. Reassemble in reverse order. <p>NOTE: Be certain to replace insulation seal when oven back is re-installed.(pn.369470)</p>
<p>Oven Hi-Limit Replacement</p>	<p>WITH OVEN POWER OFF</p> <ul style="list-style-type: none"> Remove oven back assembly. (See OVEN BACK REMOVAL) Remove two (2) wires from thermostat. Remove retaining nut from the front of thermostat and remove thermostat. Remove capillary tube from bracket in back of oven and remove assembly out through control box side. Reassemble in reverse order. Check for proper routing through insulation. Be sure capillary tube is held securely in the bracket and the reset button has been pushed in and set. <p>NOTE: All excess capillary tubing should be brought back into control box area. Be certain to replace insulation seal when oven back is re-installed.</p>
<p>Thermocouple Replacement</p>	<p>WITH OVEN POWER OFF</p> <ul style="list-style-type: none"> Remove oven back assembly. (See OVEN BACK REMOVAL) Remove thermocouple sensor from wire form in rear of oven cavity. Disconnect and mark wires from control board (red=neg., white=pos.) and remove thermocouple. Reassemble in reverse order keeping junction inside the control box and not in the heating cavity. Check operation. <p>NOTE: Be certain to replace insulation seal when oven back is re-installed.(369470)</p>
<p>Power Switch Replacement</p>	<p>WITH OVEN POWER OFF</p> <ul style="list-style-type: none"> Remove conveyor and oven side panels. Remove two (2) screws from ends of control panel and remove panel. Disconnect four (4) wires from switch assembly. Mark wires for reinstallation. Depress clips on side of switch and remove from panel. Reassemble in reverse order and check operation.

Main Fan Removal	<p>WITH OVEN POWER OFF</p> <ul style="list-style-type: none"> Remove oven back assembly. (See OVEN BACK REMOVAL) Loosen two (2) screws on fan hub and slide fan off of motor shaft. (Note location of fan on motor shaft for reinstallation is 3/16" (4.5 mm) from back wall.) Reinstall in reverse order and check system operation. Allow 30 minute preheat and verify that fan is not rubbing. <p>NOTE: Be certain to replace insulation seal when oven back is re-installed.(pn.369470)</p>
Heating Element Removal	<p>WITH OVEN POWER OFF</p> <ul style="list-style-type: none"> Remove oven back assembly. (See OVEN BACK REMOVAL) Remove three (3) screws from heating element brackets and slide element out of back assembly. Reassemble in reverse order. Verify by color code, dot or band on element that correct element is being installed. <p>NOTE: Be certain to replace insulation seal when oven back is reinstalled.(pn.369470)</p>
Air Pump Removal	<p>WITH OVEN POWER OFF</p> <ul style="list-style-type: none"> Remove oven back assembly. (See OVEN BACK REMOVAL) Remove main fan. (See MAIN FAN REMOVAL) Remove heating element. (See HEATING ELEMENT REMOVAL) Remove five (5) screws from inner back assembly and lift off. Loosen two screws on air pump hub and slide off shaft. (Note location for reinstallation, approximately 3/64" (1.2 mm) clearance from back wall). Reinstall in reverse order and check operation. Allow 30 minute preheat and verify that fan is not rubbing. <p>NOTE: Be certain to replace insulation seal when oven back is re-installed. (pn.369470)</p>
Fan Motor Removal	<p>WITH OVEN POWER OFF</p> <ul style="list-style-type: none"> Remove oven back assembly. (See OVEN BACK REMOVAL) Remove main fan. (See MAIN FAN REMOVAL) Remove heating element. (See HEATING ELEMENT REMOVAL) Remove air pump assembly. (See AIR PUMP REMOVAL) Remove four (4) screws from motor mount pedestal and lift motor and pedestal off outer back assembly. Remove four (4) nuts from front motor studs and remove mounting pedestal. Reassemble in reverse order and check operation.

	<p>NOTE: Be certain to replace insulation seal when oven back is re-installed (pn.369470).</p>
<p>Conveyor</p>	<p>To remove or add section of Belting</p> <ul style="list-style-type: none"> • Locate connecting links on the conveyor belt, turn belt to place the links on the top left end of the conveyor, approximately 8" (203mm) from the shaft. • If belt is too tight or loose, a belt link will have to be installed or removed. Proper tension allows the belt to be lifted within 2" (51mm) from the top of the conveyor opening. • You can remove the connecting links by grasping them with a pair of pliers and slipping the eye of the connecting link over the wire of the other belt links. Remember this process for reinstallation. • To add a belt link just insert or snap in one belt link at a time into the last link of the upper section of belting. • To remove a belt link just grasp the end of the last belt link of the upper section and pull out. • Reconnect connecting links by reversing process as they were removed. <p>To replace Belting</p> <ul style="list-style-type: none"> • Remove the connecting links by grasping them with a pair of pliers and slipping the eye of the connecting link over the wire of the other links. <u>Also notice the direction of the opening on the links. – The belts will have to be reinstalled with the opening facing the same way.</u> • Carefully pull out the belt, rolling it up as you go. • To reinstall put the loose end of the belt around the idler shaft and back on the conveyor. The belt must be routed on top of the lower conveyor slider bed. • NOTE: If the belting does not curl around the sprockets and lay flat, remove the belting and turn the belting over. • Remove belt links as needed for proper tension. • Reconnect connecting links by reversing process as they were removed.

GENERAL VIEW

LETTER	PART NUMBER	DESCRIPTION
A	340038	Switch, Lighted Rocker
B		<i>See Membrane Switch Assembly Section in this Manual</i>
C		<i>See Cavity Assembly Section in this Manual</i>
D		<i>See Rear Wall Assembly Section in this Manual</i>
E	370020	Motor Cover Assembly
G	370041	Duct, Inner/Outer Assembly
H	370102	Cap, Flue Bottom
I	369453	Flue Duct Assembly
J	370019	Power Cord <i>(models 2501-000, 2501-010, 2501-001, 2501-002, 2501-003, 2502-000, 2502-001, 2502-002, 2510-000 only)</i>
K	<i>See illustration below</i>	Finger Assembly
L		<i>See Membrane Switch Assembly Section in this Manual</i>

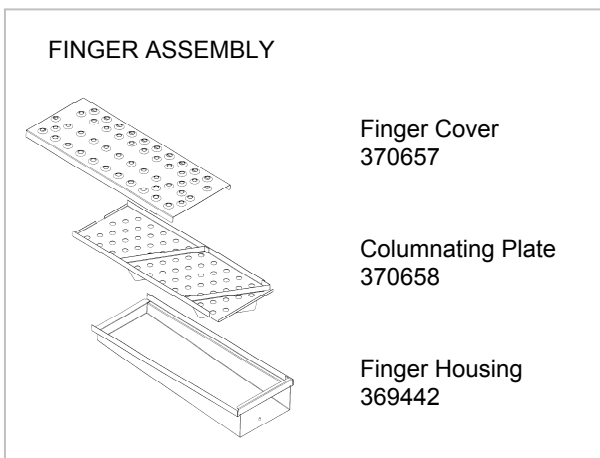
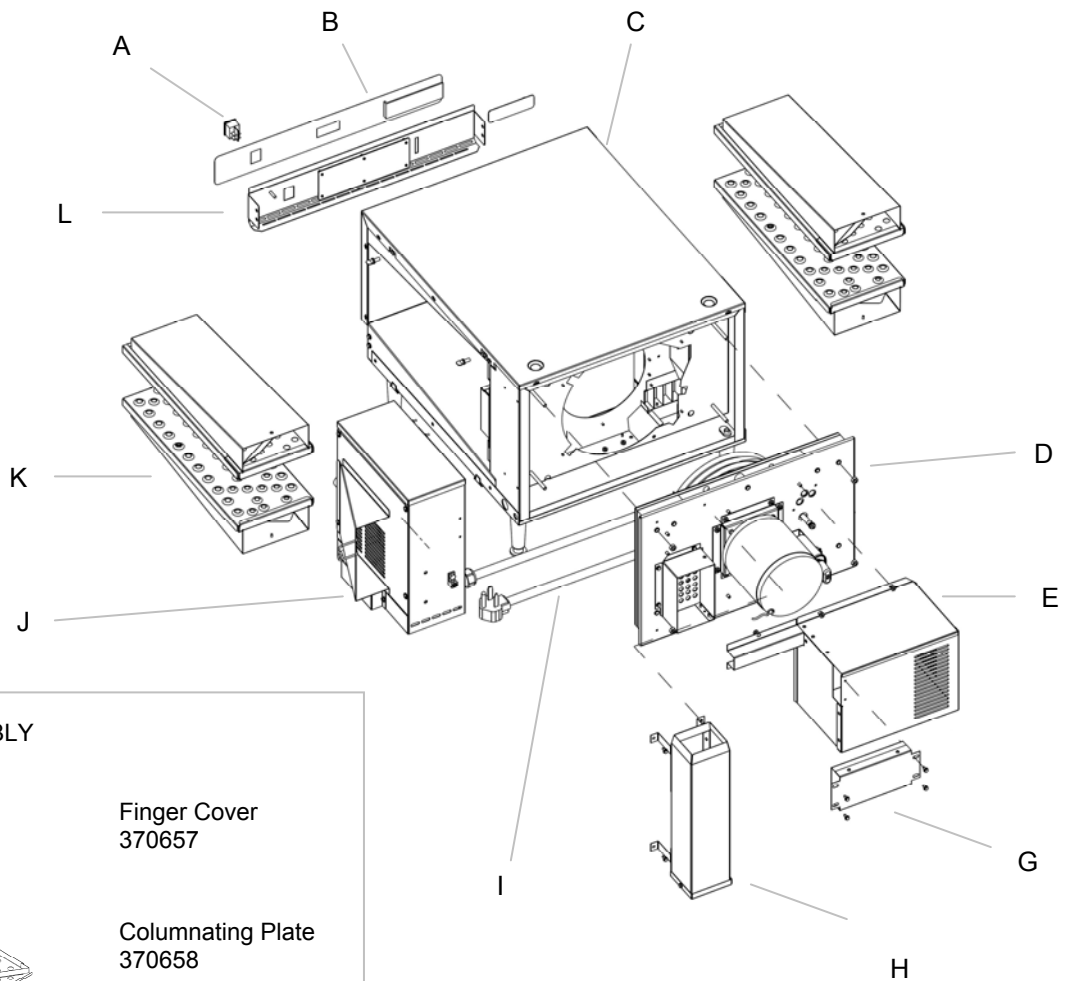

MEMBRANE SWITCH ASSEMBLY

LETTER	PART NUMBER	DESCRIPTION
A	70001558	Bracket
	4070541	Stand-Off
	10001209	10-32 x 3/4 self-clenching
B	371109	Control Board
C	10004756	Membrane Switch with Buttons <i>(All models except 2501-002 and 2502-002)</i>
	371108	Membrane Switch with Buttons <i>(Models 2501-002 and 2502-002 only)</i>

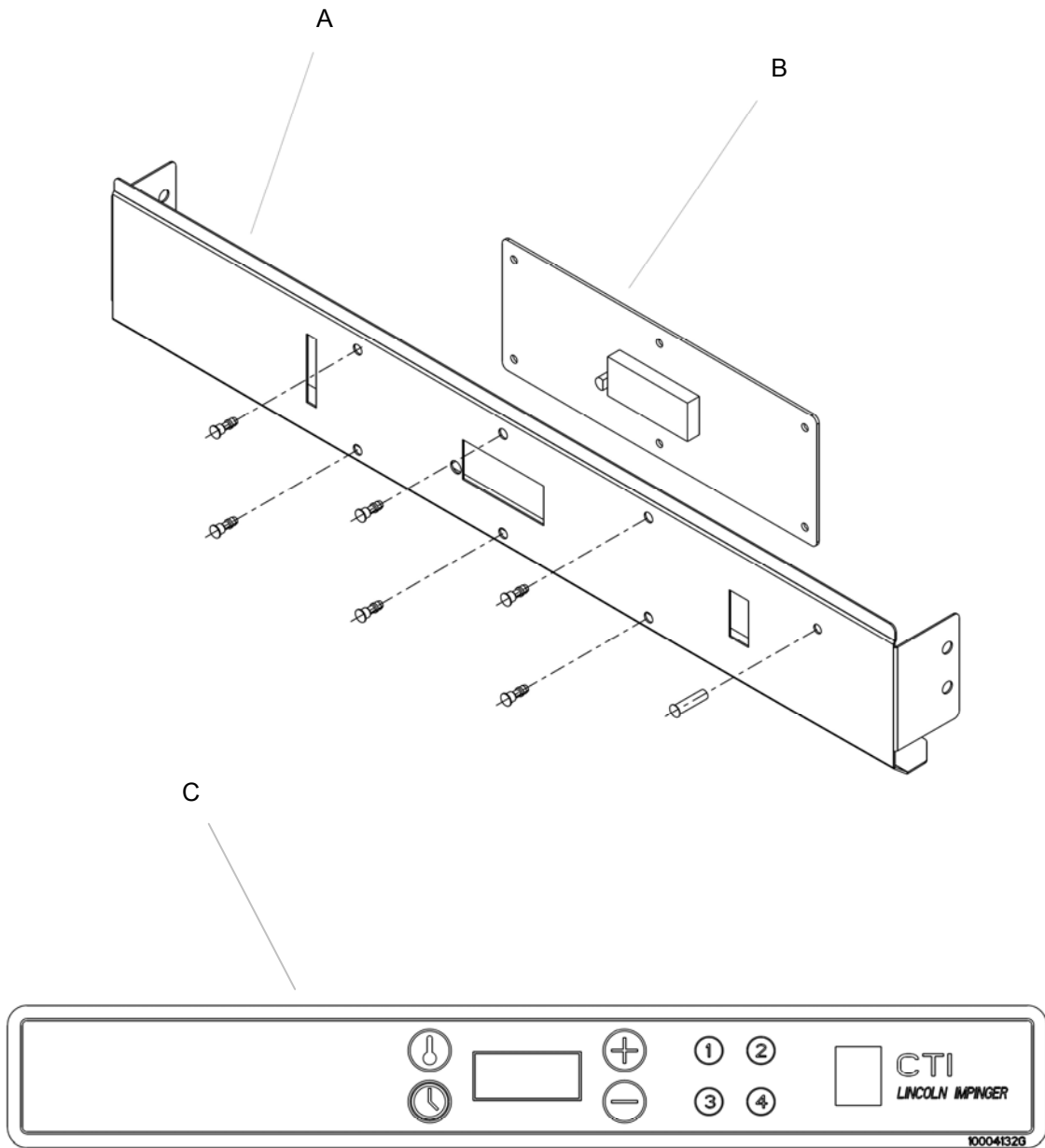

CAVITY ASSEMBLY

LETTER	PART NUMBER	DESCRIPTION
A	90000140	Cover Panel Assembly, Left Side
B	70001559	Cover, Front / Top
C	90000142	Cover Panel Assembly, Right Side
D	369495	Conveyor Baffle
E	370656	Lower Air Duct Panel (<i>all models except 2501-002 & 2502-002</i>)
	370655	Lower Air Duct Panel (<i>models 2501-002 & 2502-002 only</i>)
F	370913	Top Air Duct Panel (<i>all models except 2501-002 & 2502-002</i>)

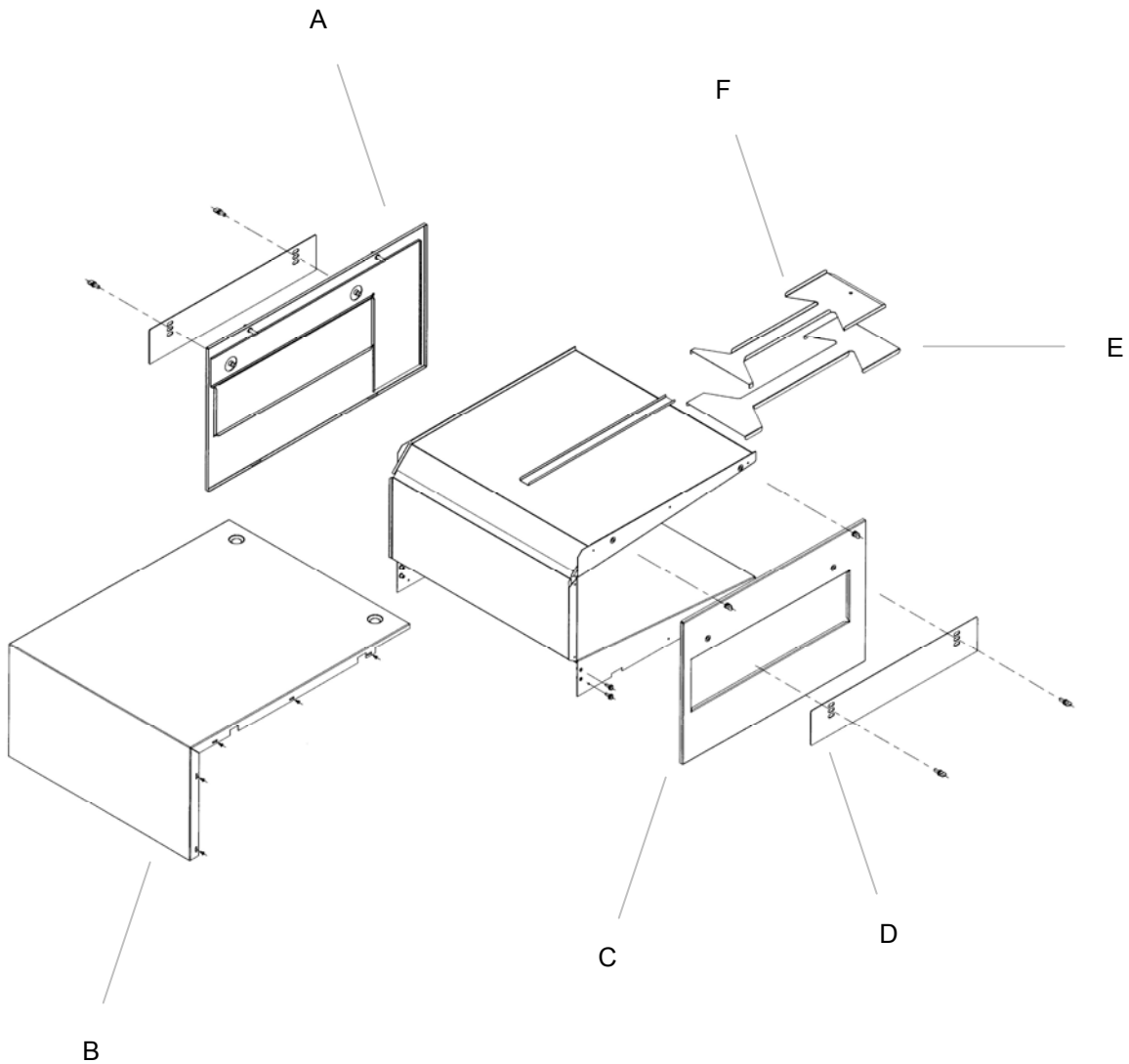

CONTROL BOX

LETTER	PART NUMBER	DESCRIPTION
A	369413	Key, Square Drive
B	369460	Compression Spring
C	350259	Screw, THMSS 6-32 x 3/8
D	369410	Coupling Sleeve
E	70001433	Plate, Reinforcement
F	369953	Flat Washer
G	70002100	Fan Cover
H	370749	Strain Relief
J	370364	Ground Lug
K	371154	EMI Filter (<i>models 2512-000, 2512-004, 2508-000, 2509-000, 2509-F06</i>)
	371157	EMI Filter (<i>models 2504-000, 2504-001, 2505-000, 2514-000</i>)
L	357067	Switch, Hi-Limit
M	370342	Fuseholder HTB-361
	369492	Fuse, Time Delay 5A
N	370767	Circuit Breaker
O	371110	Motor, Stepper
P	<i>See Control Panel Assembly section in this manual</i>	
Q	7009014	Fuse Cover
R	90001070	Cover Assembly, Control Box
Not Shown	369378	Fan Motor
Not Shown	369131	Thermocouple

CONTROL BOX VIEW

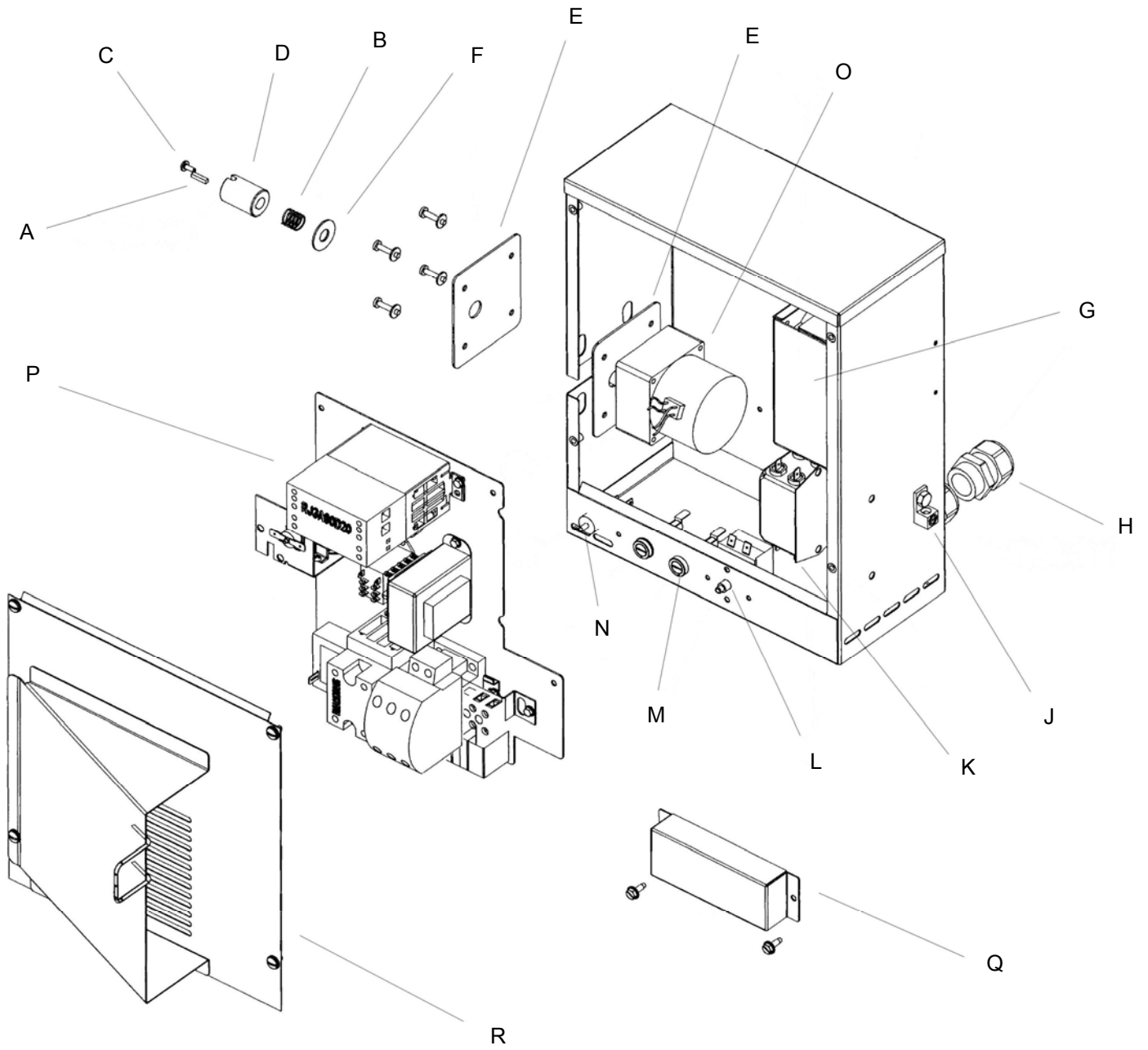

CONTROL PANEL ASSEMBLY MODELS

2501-000, 2501-010, 2501-001, 2501-002, 2501-003, 2502-000, 2502-001, 2502-002, 2510-000

LETTER	PART NUMBER	DESCRIPTION
A	370732	Transformer
B	70002102	Mounting Plate
C	370551	Rail, MDI Relay
D	370739	Contactora
E	371038	50A SSR
F	370466	Module, Time Delay, 230V
G	369422	Relay
H	369431	Hi-Limit, Control Box
J	369507	Cooling Fan Thermostat

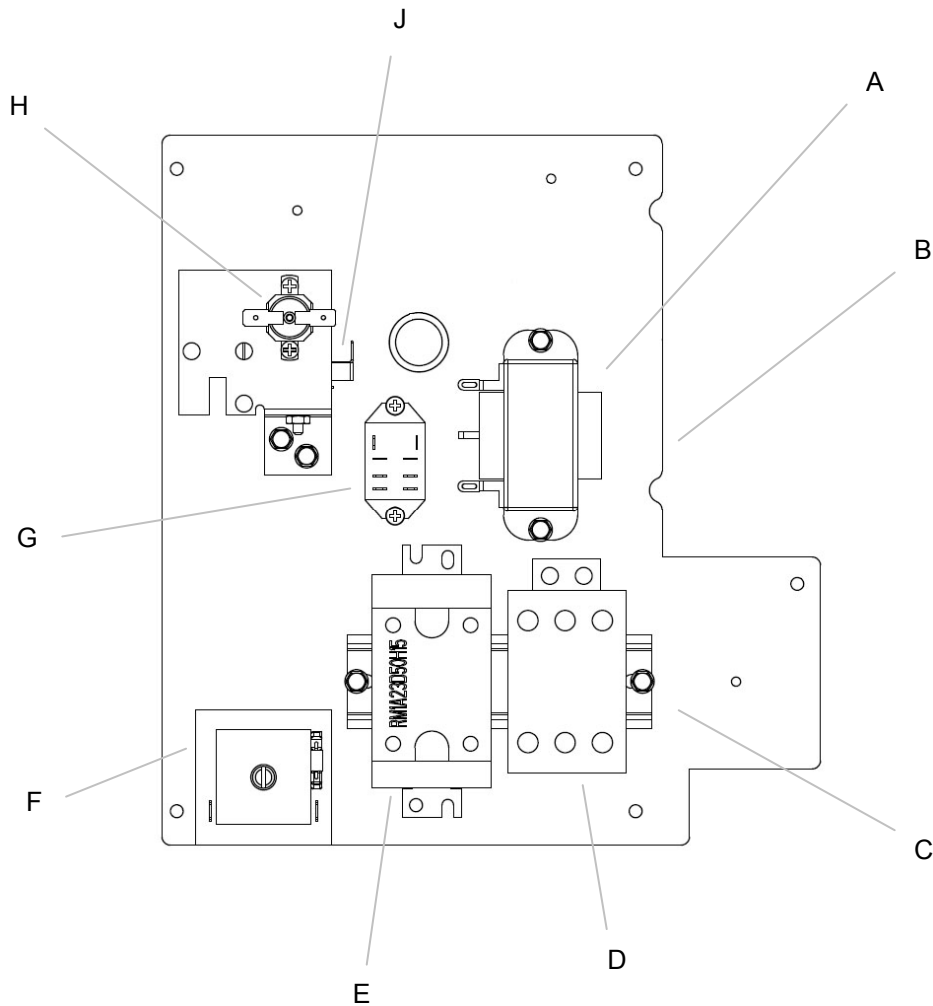

CONTROL PANEL ASSEMBLY MODEL 2514-000

LETTER	PART NUMBER	DESCRIPTION
A	371038	50A SSR
B	369507	Cooling Fan Thermostat
C	370732	Transformer
D	70002102	Mounting Plate
E	370117	Terminal Block, 5 Pole
F	9002882	Terminal Bracket Assembly
G	371158	EMI Capacitor
H	370740	Rail, Contactor
I	370739	Contactactor
J	370466	Module, Time Delay, 230V
K	369422	Relay
L	369430	Air Switch
M	369431	Hi-Limit, Control Box

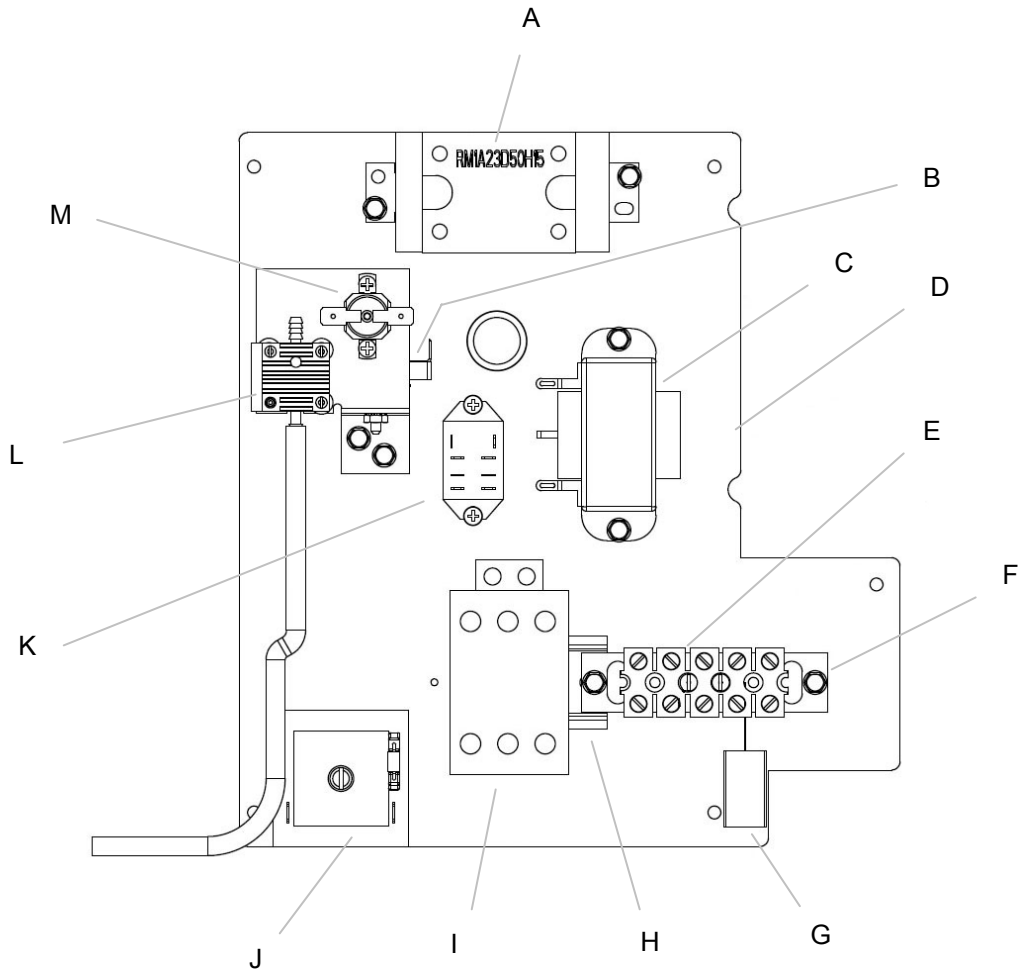

CONTROL PANEL ASSEMBLY
MODELS
2512-000, 2512-004, 2509-F06

LETTER	PART NUMBER	DESCRIPTION
A	10004413	25A SSR, 3PH
B	369507	Cooling Fan Thermostat
C	370732	Transformer
D	70002102	Mounting Plate
E	370740	Rail, Contactor
F	9002882	Terminal Bracket Assembly
G	371155	EMI Capacitor
H	370117	Terminal Block, 5 Pole
I	370739	Contactactor
J	370466	Module, Time Delay, 230V
K	369422	Relay
L	369430	Air Switch
M	369431	Hi-Limit, Control Box

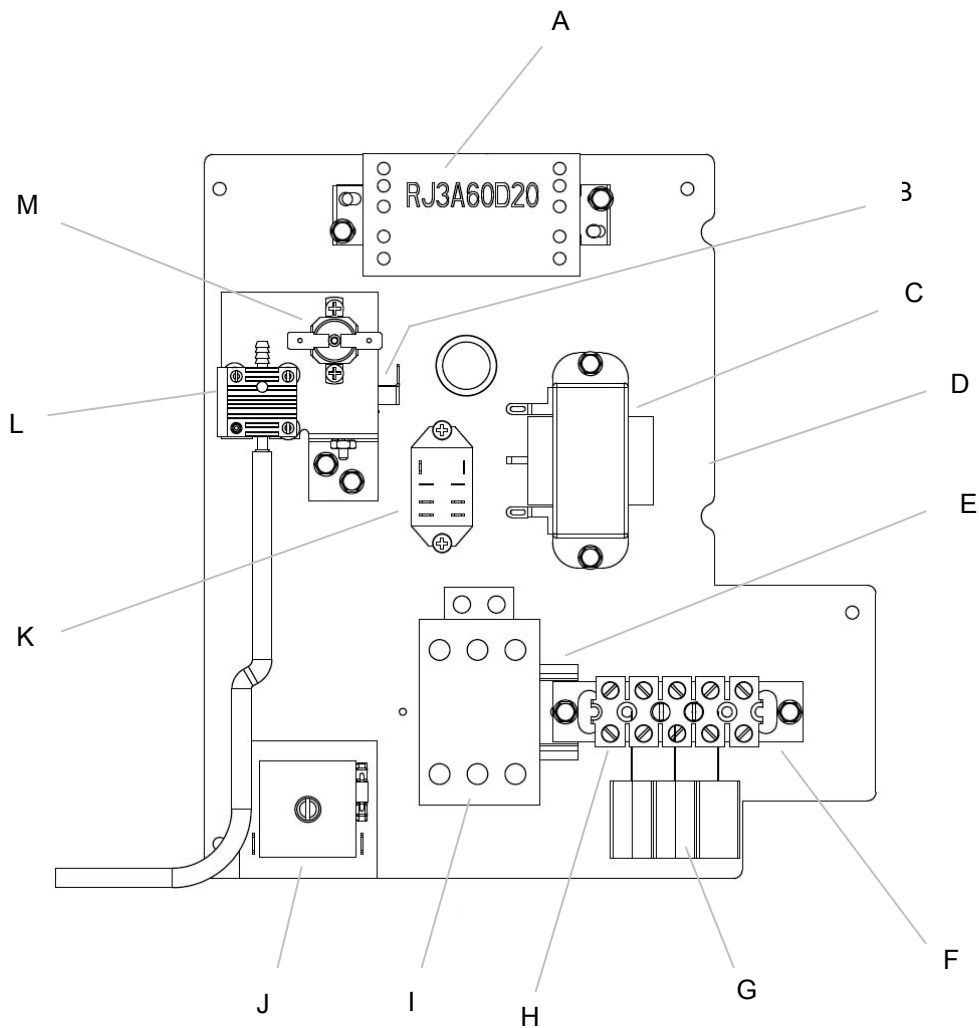

CONTROL PANEL ASSEMBLY
MODELS
2508-000, 2509-000

LETTER	PART NUMBER	DESCRIPTION
A	10004413	25A SSR, 3PH
B	369507	Cooling Fan Thermostat
C	370732	Transformer
D	70002102	Mounting Plate
E	370740	Rail, Contactor
F	9002882	Terminal Bracket Assembly
G	371155	EMI Capacitor
H	370117	Terminal Block, 5 Pole
I	370739	Contactactor
J	370466	Module, Time Delay, 230V
K	369422	Relay
L	369431	Hi-Limit, Control Box

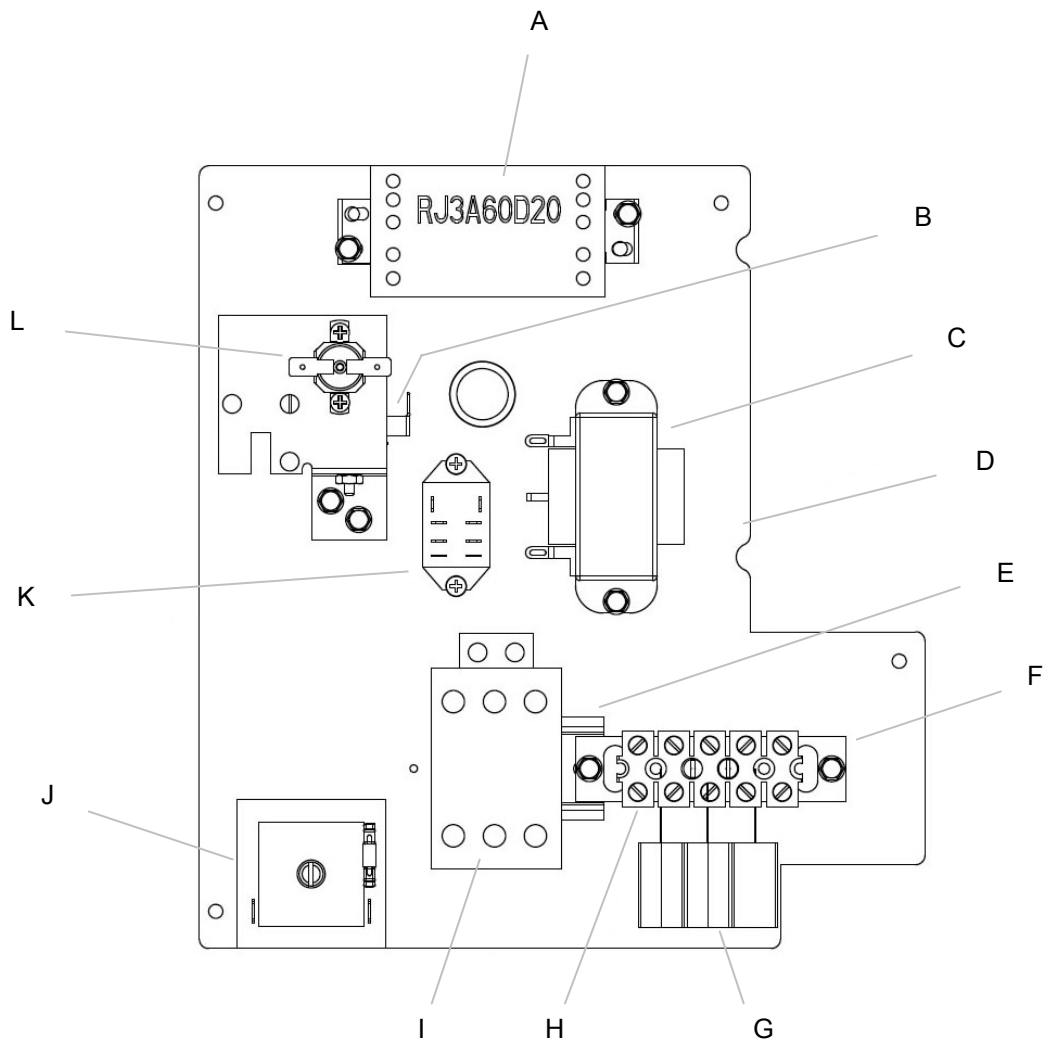

CONTROL PANEL ASSEMBLY
MODELS
2504-000, 2504-001, 2505-000

LETTER	PART NUMBER	DESCRIPTION
A	371038	50A SSR
B	369507	Cooling Fan Thermostat
C	370732	Transformer
D	70002102	Mounting Plate
E	370740	Rail, Contactor
F	9002882	Terminal Bracket Assembly
G	371158	EMI Capacitor
H	370117	Terminal Block, 5 Pole
I	370739	Contactactor
J	370466	Module, Time Delay, 230V
K	369422	Relay
L	369431	Hi-Limit, Control Box

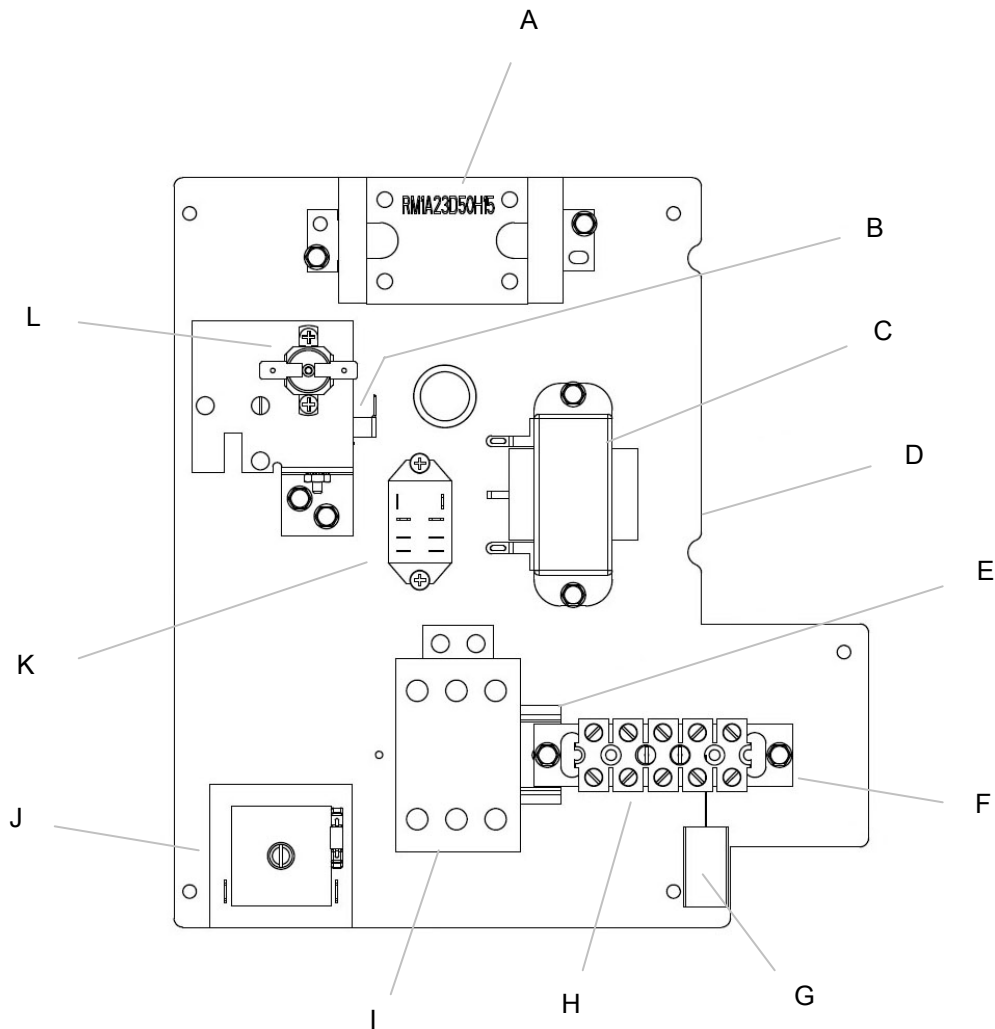

This page intentionally left blank.

OVEN BACK ASSEMBLY

LETTER	PART NUMBER	DESCRIPTION
A	369418	Heating Element, 208V, 1PH
	369419	Heating Element, 240V, 1PH
	369450	Heating Element, 220V, 1PH
	369456	Heating Element, 380V, 1PH
	369476	Heating Element, 220V, 3PH
	369477	Heating Element, 240V, 3PH
	370105	Heating Element, 400V, 1PH
	370165	Heating Element, 230V, 3PH
B	370409	Blower, Impeller Mixed Flow
C	369408	Air Pump
D	369192	Capacitor
E	370101	Mounting Bracket, Capacitor
F	369485	Motor, Main Fan, 60HZ, 1PH, 208V
	369480	Motor, Main Fan, 50/60HZ, 1PH, 220/240V
	369423	Motor, Main Fan, 50/60HZ, 1PH, 208/240V
G	369940	Motor Mount
H	9002997	Motor Plate Assembly
I	369474	Insulation, Air Pump Panel
J	369936	Plenum Barrier Panel
K	369470	Insulation Seal
L	7004840 + 7004841	Air Outlet Duct Assembly
M	369935	Cover Plate, Domestic (<i>all models except 400/230V, 3PH</i>)
	370728	Cover Plate, CE (<i>400/230V, 3PH model only</i>)
Not Shown	370020	Motor Cover Assembly (<i>see "General View" section for illustration</i>)
Not Shown	369453	Flue Duct Assembly (<i>see "General View" section for illustration</i>)

OVEN BACK ASSEMBLY VIEW

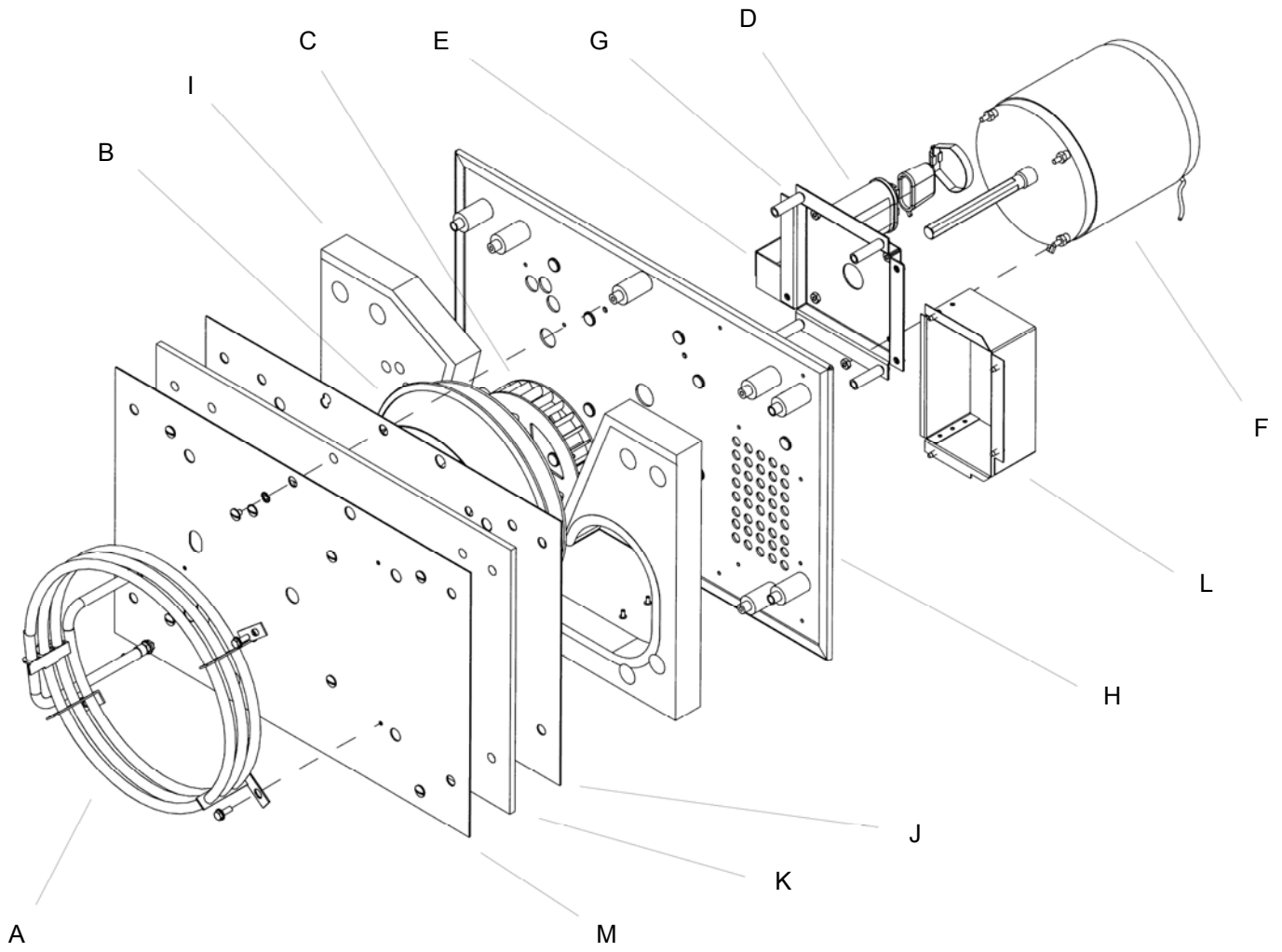

STANDARD CONVEYOR

LETTER	PART NUMBER	DESCRIPTION
	369443	Complete Standard Conveyor Assembly (31" length)
A	369462	Idler Axle
B	369515	Drive Sprocket
C	369516	Conveyor Bearing
D	369463	Drive Axle
E	369471	Roll Pin, 5/32 x 7/8"
F	1343	Entry Shelf, 12"
	1344	Entry Shelf, 4"
G	369412	Conveyor Splice Clip
H	369411	Conveyor Belting
	370185	Conveyor Belting (1 foot section)
I	1341	Exit Shelf, 12"
	1342	Exit Shelf, 4"
J	370094	Conveyor Frame Assembly

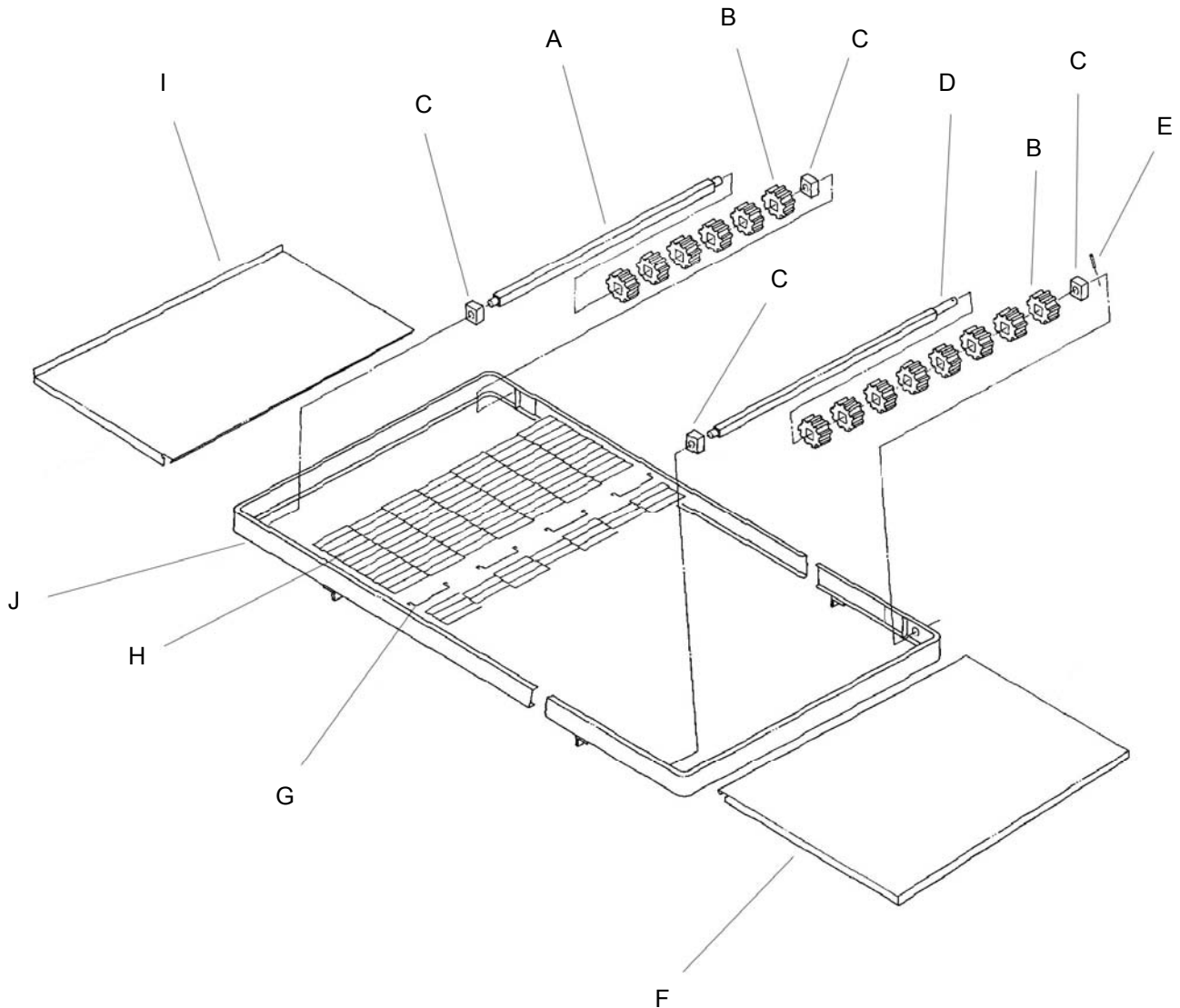

EXTENDED CONVEYOR

LETTER	PART NUMBER	DESCRIPTION
	369909	Complete Extended Conveyor Assembly (49 3/4" length)
A	369462	Idler Axle
B	369515	Drive Sprocket
C	369516	Conveyor Bearing
D	369463	Drive Axle
E	369471	Roll Pin, 5/32 x 7/8"
F	369943	Conveyor Frame, Extended
G	369412	Conveyor Splice Clip
H	369481	Conveyor Belting – Extended Conveyor
	370185	Conveyor Belting (1 foot section)
J	369921	Roller, Slider Bed
K	369954	Pop Rivet S/S
L	369922	Support Rod
M	370172	Crumb Pan Support, RH
N	370171	Crumb Pan Support, LH
Not Shown	1345	Pan Stop
Not Shown	369489	Crumb Pan Assembly

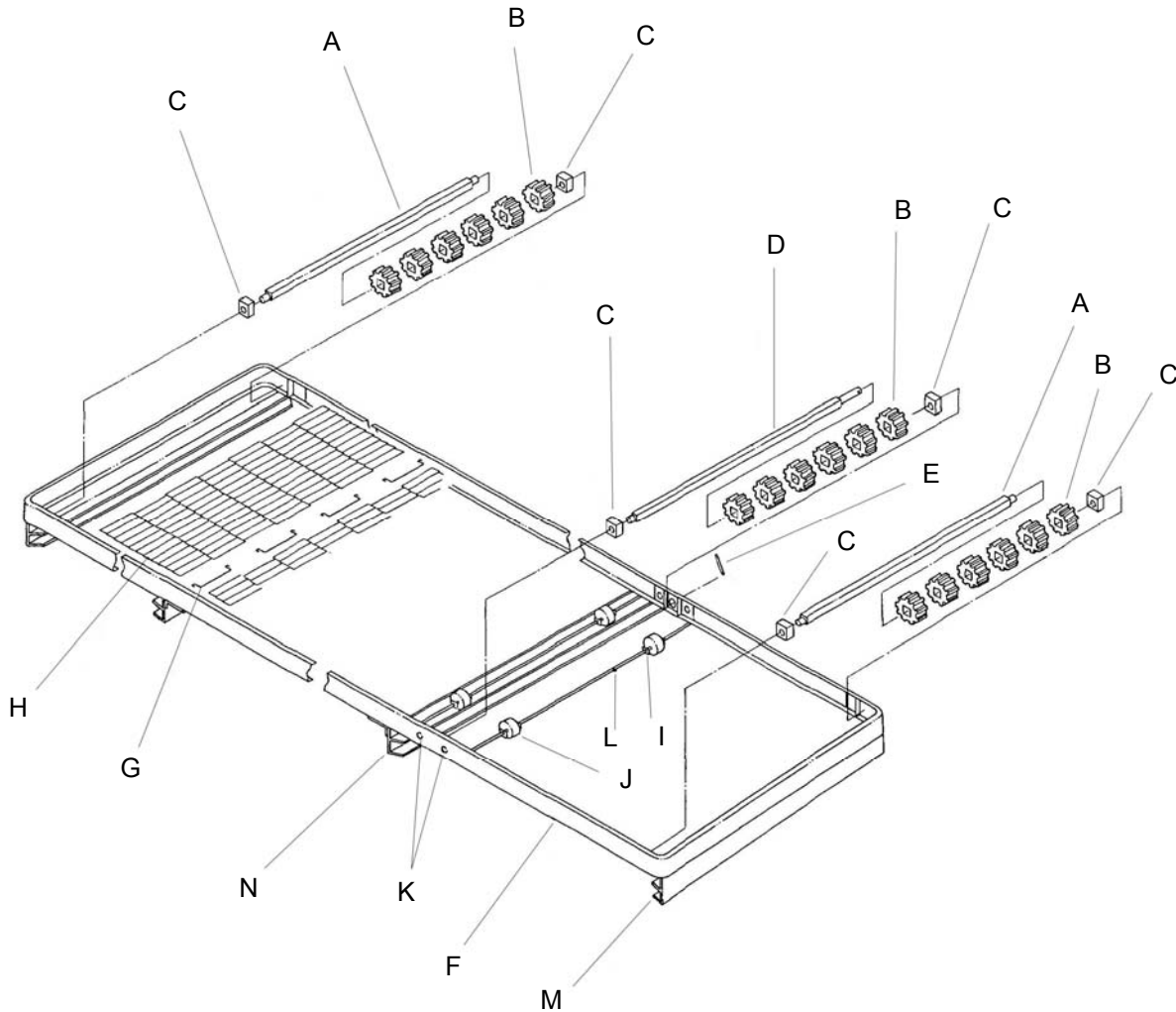

This page intentionally left blank.

This page intentionally left blank.

