

SERVICE MANUAL R410A

Outdoor unit
[Model Name]
SUZ-KA18NA2
SUZ-KA18NAH2
SUZ-KA24NA
SUZ-KA24NAH2
SUZ-KA30NA
SUZ-KA30NAH2
SUZ-KA36NA
SUZ-KA36NAH2
[Service Ref.]
SUZ-KA18NA2.TH
SUZ-KA18NAH2.TH
SUZ-KA24NA2.TH
SUZ-KA24NAH2.TH
SUZ-KA30NA2.TH
SUZ-KA30NAH2.TH
SUZ-KA36NA2.TH
SUZ-KA36NAH2.TH
Revision:

- Some descriptions have been modified in REVISED EDITION-D.

OCH688C is void.

Note:

- This manual describes service data of the outdoor units only.

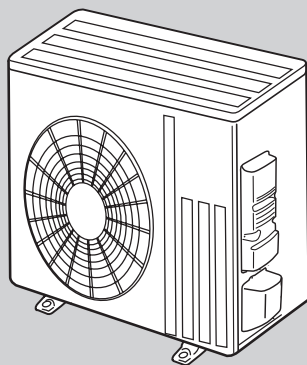
SUZ-KA18NA(H)2.TH

CONTENTS

1. COMBINATION OF INDOOR AND OUTDOOR UNITS	2
2. PART NAMES AND FUNCTIONS	2
3. SPECIFICATION	3
4. OUTLINES AND DIMENSIONS	4
5. WIRING DIAGRAM	5
6. REFRIGERANT SYSTEM DIAGRAM	9
7. DATA	11
8. ACTUATOR CONTROL	14
9. SERVICE FUNCTIONS	15
10. TROUBLESHOOTING	15
11. FUNCTION SETTING	32
12. DISASSEMBLY INSTRUCTIONS	35

PARTS CATALOG (OCB688)

1 COMBINATION OF INDOOR AND OUTDOOR UNITS

	Indoor unit		Outdoor unit			
			Heat pump type			
	Service Ref.	Service Manual No.	SUZ-			
KA18NA(H)2.TH			KA24NA(H)2.TH	KA30NA(H)2.TH	KA36NA(H)2.TH	
Heat pump without electric heater	SEZ-KD18NA4.TH	HWE08020 BWE10180	○	—	—	—
	SLZ-KF18NA.TH	OCH669 OCB669	○	—	—	—
	PEAD-A18AA7.MX	HWE16080 BWE016290	○	—	—	—
	PEAD-A24AA7.MX		—	○	—	—
	PEAD-A30AA7.MX		—	—	○	—
	PEAD-A36AA7.MX		—	—	—	○
	SVZ-KP18NA.MX	MD-1404-K019 MD-1404-K018	○	—	—	—
	SVZ-KP24NA.MX		—	○	—	—
	SVZ-KP30NA.MX		—	—	○	—
	SVZ-KP36NA.MX		—	—	—	○
	MLZ-KP18NA	OBH802 OBB802	○	—	—	—

2 PART NAMES AND FUNCTIONS

SUZ-KA18NA(H)2.TH SUZ-KA24NA(H)2.TH SUZ-KA30NA(H)2.TH SUZ-KA36NA(H)2.TH

OUTDOOR UNIT

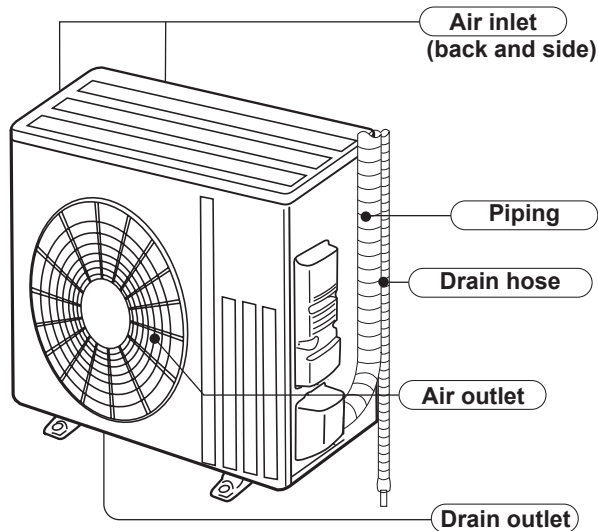

3

SPECIFICATION

Outdoor unit model			SUZ-KA18 NA(H)2	SUZ-KA24 NA(H)2	SUZ-KA30 NA(H)2	SUZ-KA36 NA(H)2
Power supply	V , phase , Hz		208/230 , 1 , 60			
Max. fuse size (time delay)	A		15	20		
Min. circuit ampacity	A		14	17		
Fan motor	F.L.A		0.67	1.00		
Compressor	Model		SNB130FQBMT	SNB220FQGM1T		
		R.L.A	10.0	13.0		
		L.R.A	12.5	16.0		
		Refrigeration oil oz. (Model)	11.8(FV50S)	15.6(FV50S)		
Refrigerant control			Linear expansion valve			
Sound level*1	Cooling	dB(A)	54	55		
	Heating	dB(A)	55			
Defrost method			Reverse cycle			
Dimensions	W	in	33-1/16			
	D	in	13			
	H	in	34-5/8			
Weight	lb		127	129		
External finish			Munsell 3Y 7.8/1.1			
Control voltage (by built-in transformer)	VDC		12 - 24			
Refrigerant piping			Not supplied			
Refrigerant pipe size (Min. wall thickness)	Liquid	in	1/4 (0.0265)	3/8(0.0285)		
	Gas	in	1/2 (0.0285)	5/8(0.0315)		
Connection method	Indoor		Flared			
	Outdoor		Flared			
Between the indoor & outdoor units	Height difference	ft	50	100		
	Piping length	ft	100			
Refrigerant charge (R410A)			3 lb. 9 oz.	4 lb. 14 oz.		

Note: Test conditions are based on AHRI 210/240.

Rating conditions (Cooling) — Indoor: 80°F D.B., 67°F W.B., Outdoor: 95°F D.B., (75°F W.B.)
 (Heating) — Indoor: 70°F D.B., 60°F W.B., Outdoor: 47°F D.B., 43°F W.B.

OPERATING RANGE

(1) POWER SUPPLY

	Rated voltage	Guaranteed voltage (V)
Outdoor unit	208/230 V 1 phase 60 Hz	Min. 187 208 230 Max. 253

4

OUTLINES AND DIMENSIONS

SUZ-KA18NA(H)2.TH SUZ-KA24NA(H)2.TH SUZ-KA30NA(H)2.TH SUZ-KA36NA(H)2.TH

Unit: inch

REQUIRED SPACE

*1 20 in. (500 mm) or more when front and sides of the unit are clear

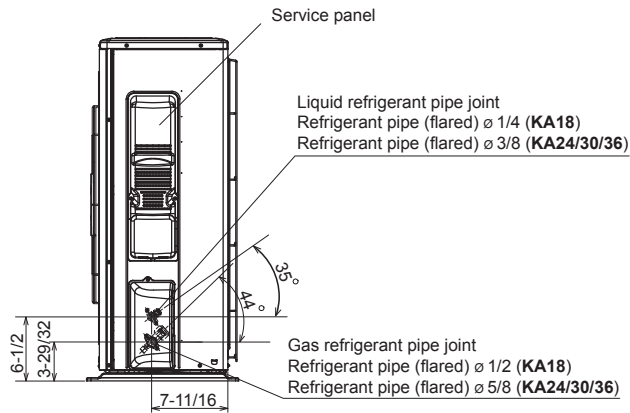
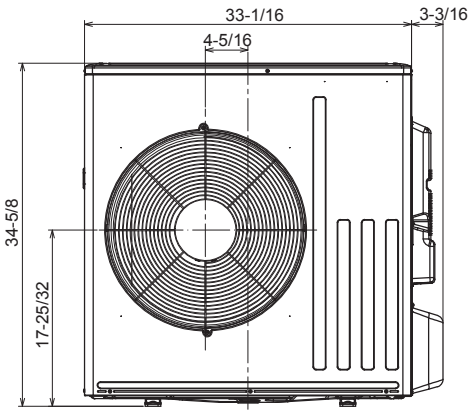
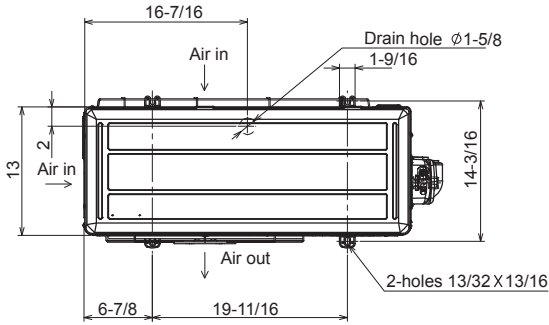
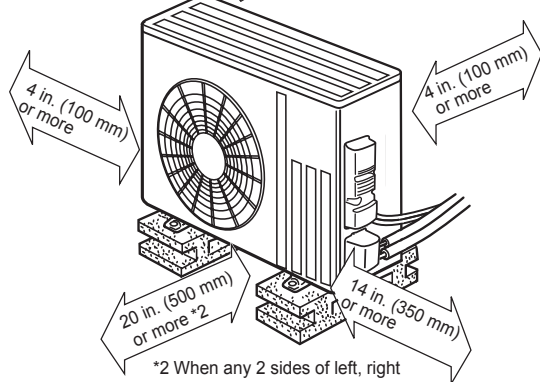

Clear *1

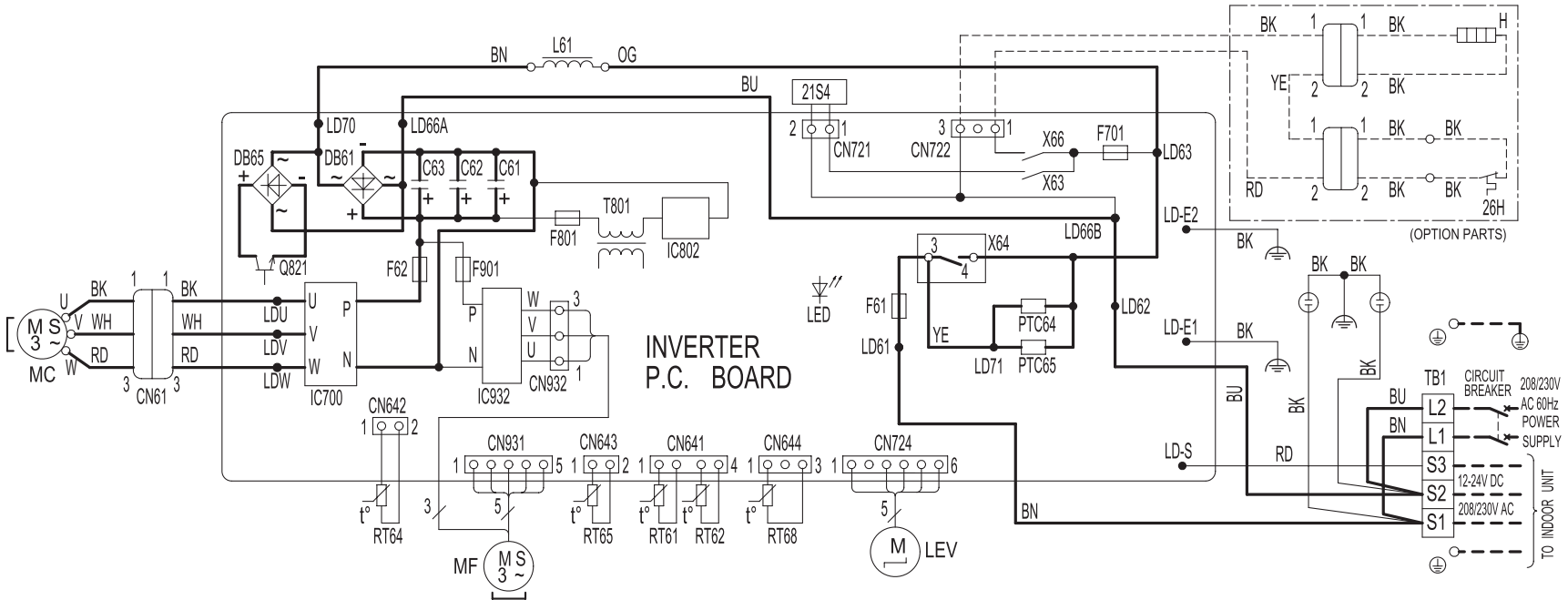

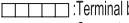

SYMBOL	NAME	SYMBOL	NAME	SYMBOL	NAME
CN61	CONNECTOR	LED	LED	RT64	FIN TEMP. THERMISTOR
C61 , C62 , C63	SMOOTHING CAPACITOR	LEV	EXPANSION VALVE COIL	RT65	AMBIENT TEMP. THERMISTOR
DB61 , DB65	DIODE MODULE	L61	REACTOR	RT68	OUTDOOR HEAT EXCHANGER TEMP. THERMISTOR
F61	FUSE (25A 250V)	MC	COMPRESSOR		
F62	FUSE (15A 250V)	MF	FAN MOTOR	TB1	TERMINAL BLOCK
F701 , F801 , F901	FUSE (T3.15A/250V)	PTC64 , PTC65	CIRCUIT PROTECTION	T801	TRANSFORMER
H	DEFROST HEATER (OPTION PARTS)	Q821	SWITCHING POWER TRANSISTOR	X63 , X64 , X66	RELAY
IC700 , IC932	POWER MODULE	RT61	DEFROST THERMISTOR	21S4	REVERSING VALVE COIL
IC802	POWER DEVICE	RT62	DISCHARGE TEMP. THERMISTOR	26H	HEATER PROTECTOR (OPTION PARTS)

NOTES:

- 1.About the indoor side electric wiring, refer to the indoor unit electric wiring diagram for servicing.
- 2.Use copper supply wires.
- 3.Symbols indicate, :Terminal block
:Connector

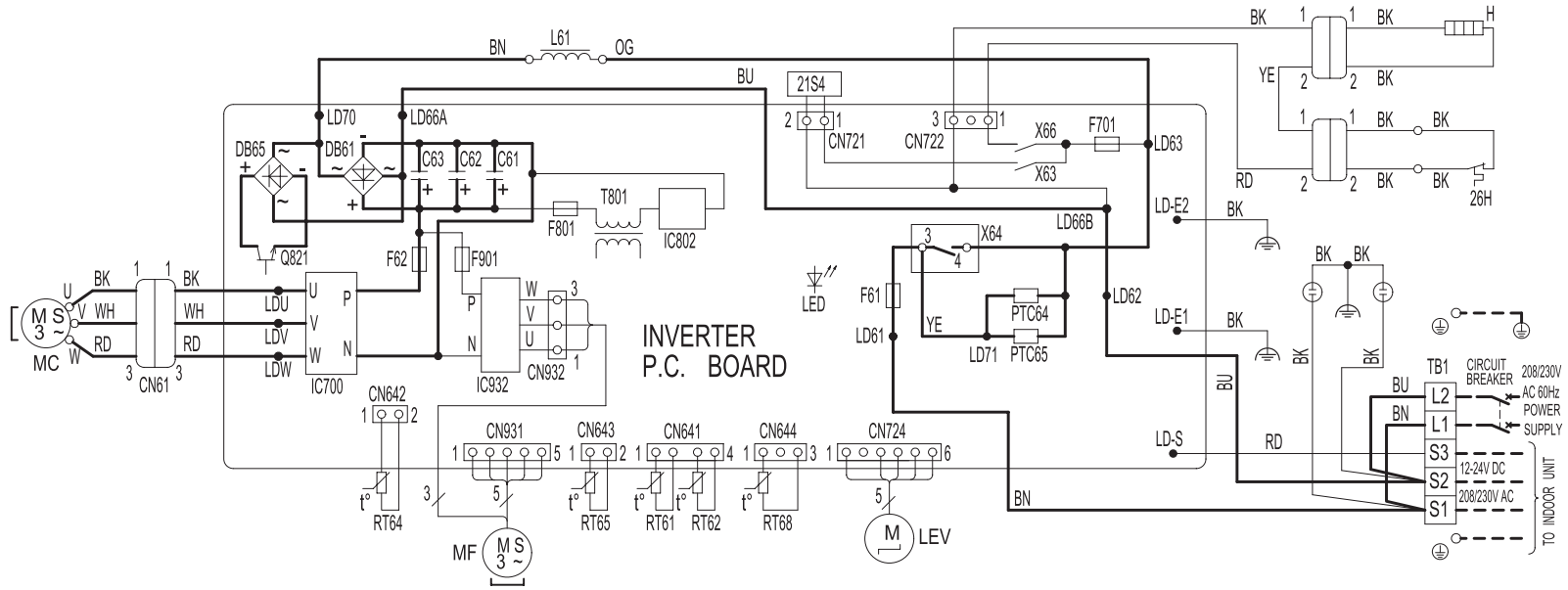

SYMBOL	NAME	SYMBOL	NAME	SYMBOL	NAME
CN61	CONNECTOR	LED	LED	RT64	FIN TEMP. THERMISTOR
C61, C62, C63	SMOOTHING CAPACITOR	LEV	EXPANSION VALVE COIL	RT65	AMBIENT TEMP. THERMISTOR
DB61, DB65	DIODE MODULE	L61	REACTOR	RT68	OUTDOOR HEAT EXCHANGER TEMP. THERMISTOR
F61	FUSE (25A 250V)	MC	COMPRESSOR	TB1	TERMINAL BLOCK
F62	FUSE (15A 250V)	MF	FAN MOTOR	T801	TRANSFORMER
F701, F801, F901	FUSE (T3.15A/250V)	PTC64, PTC65	CIRCUIT PROTECTION	X63, X64, X66	RELAY
H	DEFROST HEATER	Q821	SWITCHING POWER TRANSISTOR	21S4	REVERSING VALVE COIL
IC700, IC932	POWER MODULE	RT61	DEFROST THERMISTOR		
IC802	POWER DEVICE	RT62	DISCHARGE TEMP. THERMISTOR	26H	HEATER PROTECTOR

NOTES:

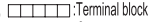
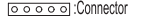
- 1.About the indoor side electric wiring, refer to the indoor unit electric wiring diagram for servicing.
- 2.Use copper supply wires.
- 3.Symbols indicate, :Terminal block
:Connector

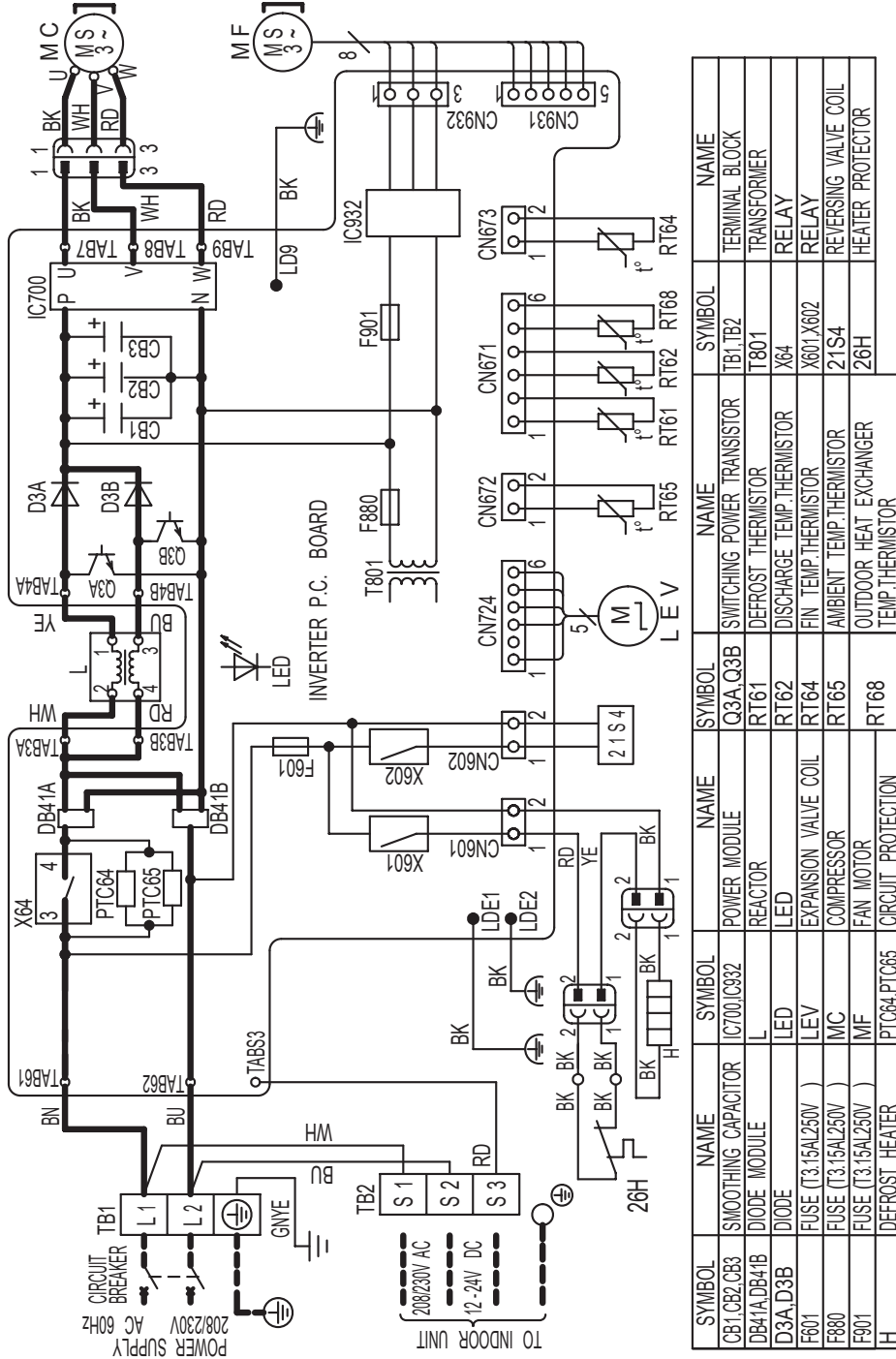

NOTES 1. About the indoor side electric wiring, refer to the indoor unit electric wiring diagram for servicing.
 2. Use copper supply wires.
 3. Symbols indicate: :Terminal block :Connector

SYMBOL	NAME	SYMBOL	NAME	SYMBOL	NAME	SYMBOL	NAME
CB1,CB2,CB3	SMOOTHING CAPACITOR	IC700,IC932	POWER MODULE	Q3A,Q3B	SWITCHING POWER TRANSISTOR	TB1,TB2	TERMINAL BLOCK
DB41A,DB41B	DIODE MODULE	L	REACTOR	RT61	DEFROST THERMISTOR	T801	TRANSFORMER
D3A,D3B	DIODE	LED	LED	RT62	DISCHARGE TEMP.THERMISTOR	X84	RELAY
F601	FUSE (T3.15A/250V)	LEV	EXPANSION VALVE COIL	RT64	FIN TEMP.THERMISTOR	X601,X602	RELAY
F880	FUSE (T3.15A/250V)	MC	COMPRESSOR	RT65	AMBIENT TEMP.THERMISTOR	21S4	REVERSING VALVE COIL
F901	FUSE (T3.15A/250V)	MF	FAN MOTOR	RT68	OUTDOOR HEAT EXCHANGER TEMP.THERMISTOR	26H	HEATER PROTECTOR
H	DEFROST HEATER	PTC64,PTC65	CIRCUIT PROTECTION				

6

REFRIGERANT SYSTEM DIAGRAM

SUZ-KA18NA(H)2.TH

Unit: inch (mm)

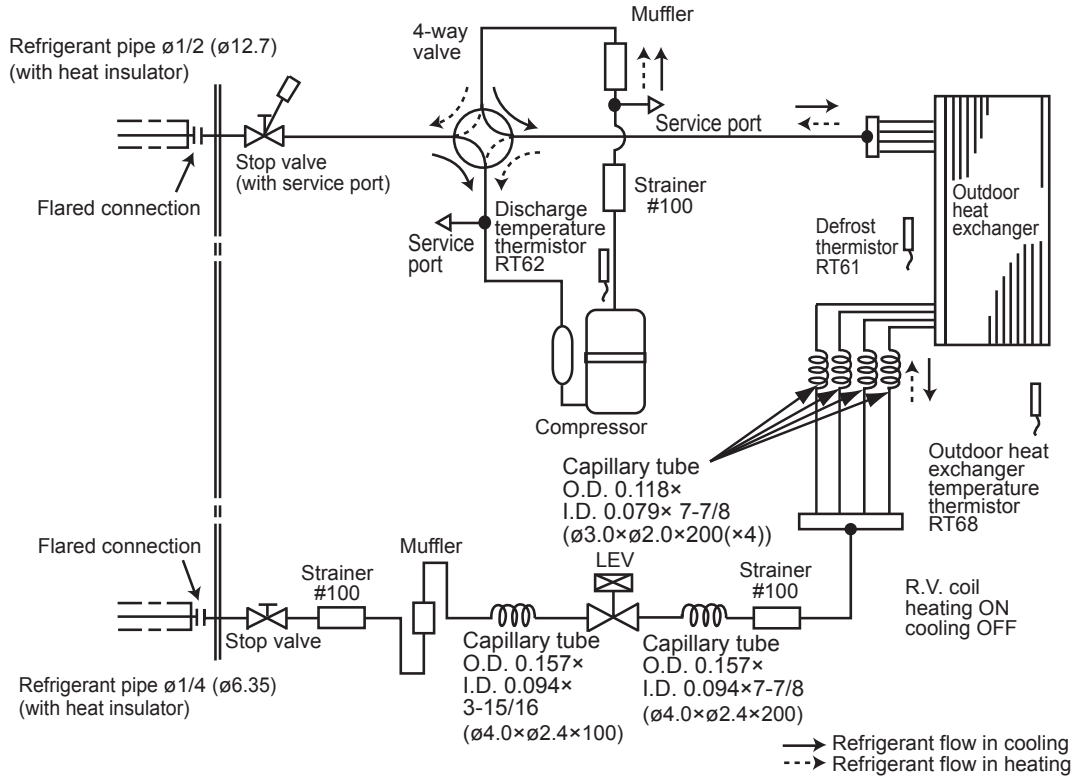

SUZ-KA24NA(H)2.TH SUZ-KA30NA(H)2.TH SUZ-KA36NA(H)2.TH

Unit: inch (mm)

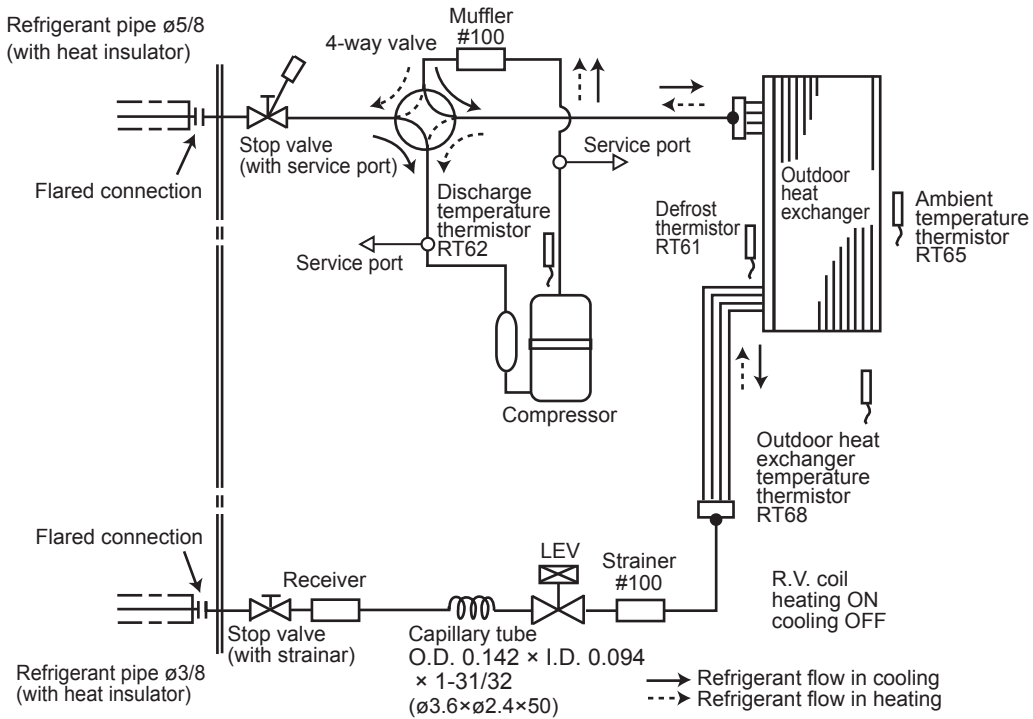

MAX. REFRIGERANT PIPING LENGTH and MAX. HEIGHT DIFFERENCE

Model	Refrigerant piping: ft.		Piping size O.D: in.	
	Max. Length A	Max. Height difference B	Gas	Liquid
SUZ-KA18/NA(H)2	100	50	1/2	1/4
SUZ-KA24/30/36 NA(H)2		100	5/8	3/8

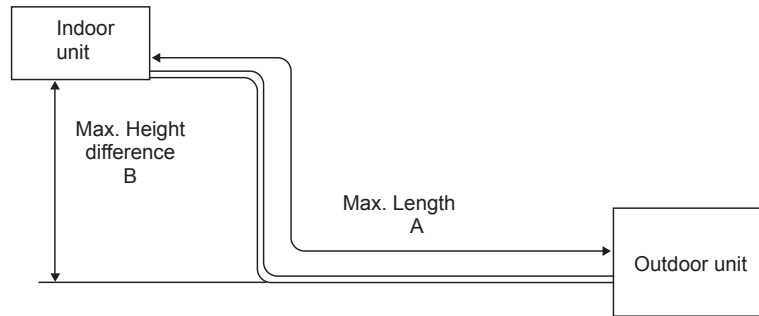

ADDITIONAL REFRIGERANT CHARGE (R410A: oz.)

NOTE: Refrigerant piping exceeding 25 ft. requires additional refrigerant charge according to the calculation.

Model	Outdoor unit precharged	Refrigerant piping length (one way): ft.								
		25	30	40	50	60	70	80	90	100
SUZ-KA18NA2 SUZ-KA18NAH2	3 lb. 9 oz.	0	1.08	3.24	5.40	7.56	9.72	11.88	14.04	16.20

Calculation: X oz. = 1.08/5 oz./ft. × (Refrigerant piping length (ft.) - 25)

Model	Outdoor unit precharged	Refrigerant piping length (one way): ft.								
		25	30	40	50	60	70	80	90	100
SUZ-KA24/30/36 NA(H)2	4 lb. 14 oz.	0	2.69	8.07	13.45	18.83	24.21	29.59	34.97	40.35

Calculation: X oz. = 2.65/5 oz./ft. × (Refrigerant piping length (ft.) - 25)

STANDARD OPERATION DATA

Representative matching			SEZ-KD18NA4		SLZ-KF18NA		PEAD-A18AA7		PEAD-A24AA7		
Item		Unit	Cooling	Heating	Cooling	Heating	Cooling	Heating	Cooling	Heating	
Total	Capacity	Btu/h	18000	21600	17700	19700	18000	21600	24000	25000	
	SHF	–	0.82	–	0.71	–	0.80	–	0.77	–	
	Input	kW	1.31	1.58	1.41	1.85	1.27	1.6	1.92	1.99	
Electrical circuit	Indoor unit		SEZ-KD18NA4		SLZ-KF18NA		PEAD-A18AA7		PEAD-A24AA7		
	Power supply (V, phase, Hz)		230, 1, 60		230, 1, 60		230, 1, 60				
	Input	kW	0.09	0.07	0.04	0.04	0.11	0.09	0.12	0.1	
	Current	A	0.74	0.63	0.43	0.38	0.95	0.84	1.03	0.92	
	Outdoor unit		SUZ-KA18 NA(H)2		SUZ-KA18 NA(H)2		SUZ-KA18 NA(H)2		SUZ-KA24 NA(H)2		
	Power supply (V, phase, Hz)		230, 1, 60		230, 1, 60		230, 1, 60				
	Input	kW	1.22	1.51	1.37	1.81	1.16	1.51	1.8	1.89	
	Current	A	4.96	6.24	5.70	7.66	4.57	6.12	7.32	7.73	
Refrigerant circuit	Condensing pressure		PSIG	369	366	372	492	371	365	411	418
	Suction pressure		PSIG	141	100	125	105	135	100	140	108
	Discharge temperature		°F	158	167	155	174	158	167	161	162
	Condensing temperature		°F	111	110	111	128	111	110	119	120
	Suction temperature		°F	56	41	46	34	57	41	51	35
	Ref. pipe length		ft.	25		25		25			
Refrigerant charge (R410A)		–	1.6		1.6		1.6		2.2		
Indoor unit	Intake air temperature	DB	°F	80	70	80	70	80	70	80	70
		WB	°F	67	60	67	60	67	60	67	60
	Discharge air temperature	DB	°F	57	101	56	108	56	103	56	101
Outdoor unit	Intake air temperature	DB	°F	95	47	95	47	95	47	95	47
		WB	°F	75	43	75	43	75	43	75	43

Representative matching		PEAD-A30AA7		PEAD-A36AA7		SVZ-KP18NA		SVZ-KP24NA			
Item		Unit	Cooling	Heating	Cooling	Heating	Cooling	Heating	Cooling	Heating	
Total	Capacity	Btu/h	27000	30000	33000	33400	18000	21600	24000	25000	
	SHF	–	0.84	–	0.84	–	0.85	–	0.81	–	
	Input	kW	2.16	2.41	3.51	3.17	1.36	1.6	1.92	1.91	
Electrical circuit	Indoor unit		PEAD-A30AA7		PEAD-A36AA7		SVZ-KP18NA		SVZ-KP24NA		
	Power supply (V, phase, Hz)		230, 1, 60				230, 1, 60				
	Input	kW	0.17	0.15	0.25	0.23	0.16		0.18		
	Current	A	1.31	1.2	1.71	1.6	1.44		1.6		
	Outdoor unit		SUZ-KA30 NA(H)2		SUZ-KA36 NA(H)2		SUZ-KA18 NA(H)2		SUZ-KA24 NA(H)2		
	Power supply (V, phase, Hz)		230, 1, 60				230, 1, 60				
	Input	kW	1.99	2.26	3.26	2.94	1.2	1.44	1.74	1.73	
	Current	A	8.08	9.28	13.55	12.18	4.47	5.52	6.75	6.70	
Refrigerant circuit	Condensing pressure	PSIG	419	417	456	356	369	349	411	415	
	Suction pressure	PSIG	147	105	142	97	144	100	145	108	
	Discharge temperature	°F	164	162	176	176	158	158	156	167	
	Condensing temperature	°F	120	120	127	108	111	108	116	119	
	Suction temperature	°F	53	34	50	30	58	37	59	35	
	Ref. pipe length	ft.	25				25				
	Refrigerant charge (R410A)	–	2.2				1.6		2.2		
Indoor unit	Intake air temperature	DB	°F	80	70	80	70	80	70	80	70
		WB	°F	67	60	67	60	67	60	67	60
	Discharge air temperature	DB	°F	58	98	57	95	58	100	59	96
Outdoor unit	Intake air temperature	DB	°F	95	47	95	47	95	47	95	47
		WB	°F	75	43	75	43	75	43	75	43

Representative matching			SVZ-KP30NA		SVZ-KP36NA		MLZ-KP18NA		
Item		Unit	Cooling	Heating	Cooling	Heating	Cooling	Heating	
Total	Capacity	Btu/h	27000	30000	33400	33400	18000	20000	
	SHF	–	0.9	–	0.84	–	0.67	–	
	Input	kW	2.16	2.06	3.71	3.03	1.44	1.77	
Electrical circuit	Indoor unit		SVZ-KP30NA		SVZ-KP36NA		MLZ-KP18NA		
	Power supply (V, phase, Hz)		230, 1, 60				230, 1, 60		
	Input	kW	0.21		0.34		0.04		
	Current	A	2.0		3.0		0.4		
	Outdoor unit		SUZ-KA30 NA(H)2		SUZ-KA36 NA(H)2		SUZ-KA18 NA(H)2		
	Power supply (V, phase, Hz)		230, 1, 60				230, 1, 60		
	Input	kW	1.95	1.85	3.38	2.69	1.4	1.73	
	Current	A	7.39	6.96	13.17	10.17	5.86	7.30	
Refrigerant circuit	Condensing pressure	PSIG	414	322	453	336	368	453	
	Suction pressure	PSIG	155	87	139	95	123	105	
	Discharge temperature	°F	160	159	174	175	164	175	
	Condensing temperature	°F	116	102	124	109	110	118	
	Suction temperature	°F	61	39	55	36	56	34	
	Ref. pipe length	ft.	25				25		
	Refrigerant charge (R410A)	–	2.2				1.6		
Indoor unit	Intake air temperature	DB	°F	80	70	80	70	80	70
		WB	°F	67	60	67	60	67	60
	Discharge air temperature	DB	°F	60	93	59	99	52	117
Outdoor unit	Intake air temperature	DB	°F	95	47	95	47	95	47
		WB	°F	75	43	75	43	75	43

8-1. OUTDOOR FAN MOTOR CONTROL

The fan motor turns ON/OFF, interlocking with the compressor.

[ON] The fan motor turns ON 5 seconds before the compressor starts up.

[OFF] The fan motor turns OFF 15 seconds after the compressor has stopped running.

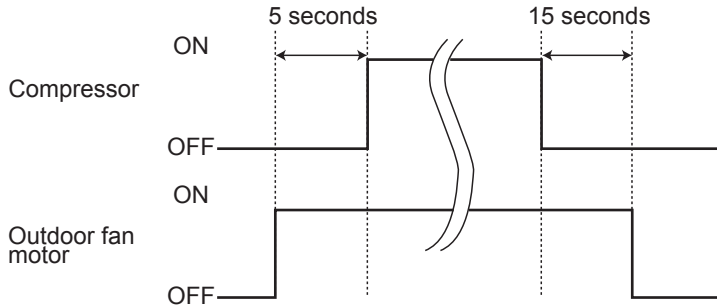

8-2. R.V. COIL CONTROL

Heating ON

Cooling OFF

Dry OFF

NOTE: The 4-way valve reverses for 5 seconds right before start-up of the compressor.

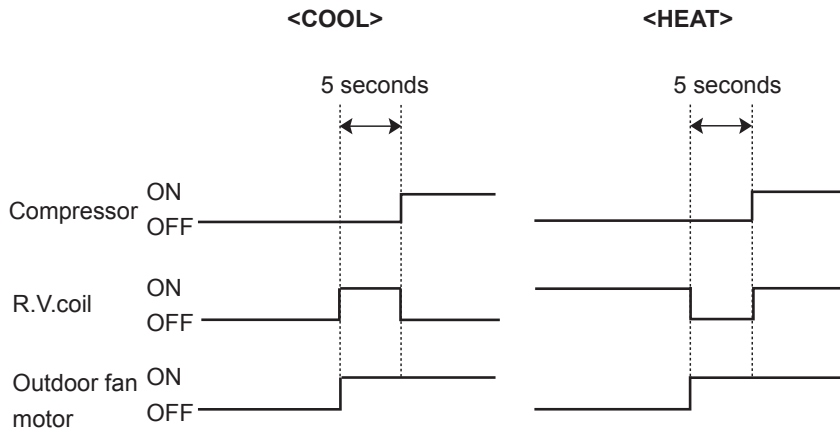

8-3. RELATION BETWEEN MAIN SENSOR AND ACTUATOR

Sensor	Purpose	Actuator				
		Compressor	LEV	Outdoor fan motor	R.V.coil	Indoor fan motor
Discharge temperature thermistor	Protection	○	○			
Indoor coil temperature thermistor	Cooling: Coil frost prevention	○				
	Heating: High pressure protection	○	○			
Defrost thermistor	Heating: Defrosting	○	○	○	○	○
Fin temperature thermistor	Protection	○		○		
Ambient temperature thermistor	Cooling: Low ambient temperature operation	○	○	○		
Outdoor heat exchanger temperature thermistor	Cooling: Low ambient temperature operation	○	○	○		
	Cooling: High pressure protection	○	○	○		

9

SERVICE FUNCTIONS

9-1. CHANGE IN DEFROST SETTING

Changing defrost finish temperature

<JS> To change the defrost finish temperature, cut/solder the JS wire of the outdoor inverter P.C. board. (Refer to "10-6. TEST POINT DIAGRAM AND VOLTAGE".)

Jumper		Defrost finish temperature	
		SUZ-KA18NA(H)2	SUZ-KA24/30/36NA(H)2
JS	Soldered (Initial setting)	48°F (9°C)	50°F (10°C)
	None (Cut)	64°F (18°C)	64°F (18°C)

9-2. PRE-HEAT CONTROL SETTING

PRE-HEAT CONTROL

When moisture gets into the refrigerant cycle, it may interfere the start-up of the compressor at low outside temperature. The pre-heat control prevents this interference. The pre-heat control turns ON when outside temperature is 68°F (20°C) or below. When pre-heat control is turned ON, compressor is energized. (About 50 W)

<JK> To activate the pre-heat control, cut the JK wire of the inverter P.C. board. (Refer to "10-6. TEST POINT DIAGRAM AND VOLTAGE".)

NOTE: When the inverter P.C. board is replaced, check the Jumper wires, and cut/solder them if necessary.

10

TROUBLESHOOTING

10-1. CAUTIONS ON TROUBLESHOOTING

1. Before troubleshooting, check the following

- 1) Check the power supply voltage.
- 2) Check the indoor/outdoor connecting wire for miswiring.

2. Take care of the following during servicing

- 1) Before servicing the air conditioner, be sure to turn OFF the main unit first with the remote controller, and turn off the breaker.
- 2) Be sure to turn OFF the power supply before removing the front panel, the cabinet, the top panel, and the electronic control P.C. board.
- 3) When removing the electrical parts, be careful of the residual voltage of smoothing capacitor.
- 4) When removing the electronic control P.C. board, hold the edge of the board with care NOT to apply stress on the components.
- 5) When connecting or disconnecting the connectors, hold the housing of the connector. DO NOT pull the lead wires.

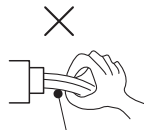

Lead wiring

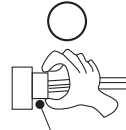

Housing point

3. Troubleshooting procedure

- 1) First, check if the OPERATION INDICATOR lamp is blinking ON and OFF to indicate an abnormality.
- 2) Before servicing check that the connector and terminal are connected properly.
- 3) When the electronic control P.C. board seems to be defective, check the copper foil pattern for disconnection and the components for bursting and discoloration.
- 4) Refer to "10-2. TROUBLESHOOTING CHECK TABLE" and "10-3. HOW TO PROCEED "SELF-DIAGNOSIS"". "



10-2. TROUBLE SHOOTING CHECK TABLE

No.	Symptoms	LED indication code	check	Abnormal point/ Condition	Condition	Remedy	No. of blinks		Symptoms
							1-time blink every 2.5 seconds	6-time blink / 2.5 seconds OFF	
1	Outdoor power system	UP	Outdoor power system	Overcurrent protection cut-out operates 3 consecutive times within 1 minute after the compressor gets started.	<ul style="list-style-type: none"> Reconnect connector of compressor. Refer to "10-5.⑦ How to check inverter/compressor". Check stop valve. 	<ul style="list-style-type: none"> Refer to "10-5.⑥ Check of outdoor thermistors". 	1-time blink every 2.5 seconds	Outdoor thermistors	Discharge temperature thermistor shorts, or opens during compressor running.
2	Outdoor thermistors	U3	Outdoor thermistors	Fin temperature thermistor, defrost thermistor, P.C. board temperature thermistor shorts, or opens during compressor running.	<ul style="list-style-type: none"> Refer to "10-5.⑥ Check of outdoor thermistors". 	<ul style="list-style-type: none"> Replace inverter P.C. board. 	6-time blink / 2.5 seconds OFF	Outdoor unit does not operate.	Nonvolatile memory data cannot be read properly.
3	Outdoor unit does not operate.	E8 / E9	Serial signal	The communication fails between the indoor and outdoor unit for 3 minutes.	<ul style="list-style-type: none"> Check indoor/outdoor connecting wire. Replace indoor or outdoor P.C. board if abnormally is displayed again. 	<ul style="list-style-type: none"> Check stop valve. 	11-time blink / 2.5 seconds OFF	Outdoor refrigerant system abnormality	A closed valve and air trapped in the refrigerant circuit are detected
4	Outdoor unit does not operate.	E8 / E9	Stop valve/ Closed valve	Closed valve is detected by compressor current.	<ul style="list-style-type: none"> Check stop valve. 	<ul style="list-style-type: none"> Check stop valve. 	16-time flash / 2.5 seconds OFF	Outdoor refrigerant system abnormality	Based on the temperature sensed by the indoor and outdoor thermistors and the current of the compressor.
5	Outdoor unit does not operate.	PL	PL	Outdoor refrigerant system abnormality	<ul style="list-style-type: none"> Check for a gas leak in a connecting piping, etc. Refer to "10-5.⑤ Check of outdoor refrigerant circuit". 	<ul style="list-style-type: none"> Reconnect connector of compressor. Refer to "10-5.⑦ How to check inverter/compressor". Check stop valve. 	2-time blink / 2.5 seconds OFF	Overcurrent protection	Large current flows into intelligent power module.
6	Outdoor unit does not operate.	PL	PL	Outdoor refrigerant system abnormality	<ul style="list-style-type: none"> Check around outdoor unit. Check outdoor unit air passage. Refer to "10-5.① Check of outdoor fan motor". 	<ul style="list-style-type: none"> Reconnect connector of compressor. Refer to "10-5.⑦ How to check inverter/compressor". Check stop valve. 	4-time blink / 2.5 seconds OFF	Fin temperature/P.C. board temperature thermistor overheating protection	Fin temperature of fin temperature thermistor on the heat sink exceeds 72 to 86°C or temperature of P.C. board temperature thermistor on the inverter P.C. board exceeds 72 to 85°C.
7	Outdoor unit stops and restarts 3 minutes later is repeated.	5-time blink / 2.5 seconds OFF	High pressure protection	Indoor coil thermistor exceeds 70°C in HEAT mode. Defrost thermistor exceeds 70°C in COOL mode.	<ul style="list-style-type: none"> Check refrigerant circuit and refrigerant amount. 	<ul style="list-style-type: none"> Refer to "10-5.⑤ Check of outdoor fan motor". 	5-time blink / 2.5 seconds OFF	Compressor synchronous abnormality	The waveform of compressor current is distorted.
8	Outdoor unit stops and restarts 3 minutes later is repeated.	3-time blink / 2.5 seconds OFF	Discharge temperature	Discharge temperature thermistor exceeds 116°C, compressor stops. Compressor can restart if discharge temperature thermistor reads 100°C or less 3 minutes later.	<ul style="list-style-type: none"> Check refrigerant circuit and refrigerant amount. Refer to "10-5.⑥ Check of LEV". 	<ul style="list-style-type: none"> Check around outdoor unit. Check outdoor unit air passage. Refer to "10-5.① Check of outdoor fan motor". 	3-time blink / 2.5 seconds OFF	Outdoor fan motor	Outdoor fan has stopped 3 times in a row within 30 seconds after outdoor fan start-up.
9	Outdoor unit stops and restarts 3 minutes later is repeated.	4-time blink / 2.5 seconds OFF	Fin temperature/P.C. board temperature thermistor overheating protection	Fin temperature of fin temperature thermistor on the heat sink exceeds 72 to 86°C or temperature of P.C. board temperature thermistor on the inverter P.C. board exceeds 72 to 85°C.	<ul style="list-style-type: none"> Check refrigerant circuit and refrigerant amount. Refer to "10-5.⑥ Check of outdoor fan motor". 	<ul style="list-style-type: none"> Refer to "10-5.⑤ Check of outdoor fan motor". 	4-time blink / 2.5 seconds OFF	Frequency drop by high pressure protection	Temperature of indoor coil thermistor exceeds 131 °F [55 °C] in HEAT mode, compressor frequency lowers.
10	Outdoor unit stops and restarts 3 minutes later is repeated.	3-time blink / 2.5 seconds OFF	Frequency drop by discharge temperature	Frequency drop by discharge temperature thermistor exceeds 232 °F [111 °C], compressor frequency lowers.	<ul style="list-style-type: none"> Check refrigerant circuit and refrigerant amount. Refer to "10-5.⑥ Check of LEV". 	<ul style="list-style-type: none"> Check if indoor filters are clogged. Check if refrigerant is short. Check if indoor/outdoor unit air circulation is short cycled. 	3-time blink / 2.5 seconds OFF	Indoor coil thermistor reads 46 °F [8 °C] or less in COOL mode, compressor frequency lowers.	Indoor coil thermistor reads 46 °F [8 °C] or less in COOL mode, compressor frequency lowers.
11	Outdoor unit stops and restarts 3 minutes later is repeated.	4-time blink / 2.5 seconds OFF	Frequency drop by discharge temperature	Frequency drop by discharge temperature thermistor exceeds 232 °F [111 °C], compressor frequency lowers.	<ul style="list-style-type: none"> Check refrigerant circuit and refrigerant amount. Refer to "10-5.⑥ Check of LEV". 	<ul style="list-style-type: none"> Check if indoor filters are clogged. Check if refrigerant is short. Check if indoor/outdoor unit air circulation is short cycled. 	4-time blink / 2.5 seconds OFF	Frequency drop by discharge temperature	Temperature of discharge temperature thermistor exceeds 232 °F [111 °C], compressor frequency lowers.
12	Outdoor unit stops and restarts 3 minutes later is repeated.	5-time blink / 2.5 seconds OFF	Frequency drop by discharge temperature	Frequency drop by discharge temperature thermistor exceeds 232 °F [111 °C], compressor frequency lowers.	<ul style="list-style-type: none"> Check refrigerant circuit and refrigerant amount. Refer to "10-5.⑥ Check of LEV". 	<ul style="list-style-type: none"> Check if indoor filters are clogged. Check if refrigerant is short. Check if indoor/outdoor unit air circulation is short cycled. 	5-time blink / 2.5 seconds OFF	Temperature of discharge temperature	Temperature of discharge temperature thermistor has been 122 °F [50 °C] or less for 20 minutes.
13	Outdoor unit stops and restarts 3 minutes later is repeated.	6-time blink / 2.5 seconds OFF	Temperature of discharge temperature	Temperature of discharge temperature thermistor has been 122 °F [50 °C] or less for 20 minutes.	<ul style="list-style-type: none"> Check refrigerant circuit and refrigerant amount. Refer to "10-5.⑥ Check of LEV". 	<ul style="list-style-type: none"> Check if indoor filters are clogged. Check if refrigerant is short. Check if indoor/outdoor unit air circulation is short cycled. 	6-time blink / 2.5 seconds OFF	Temperature of discharge temperature	Temperature of discharge temperature thermistor has been 122 °F [50 °C] or less for 20 minutes.
14	Outdoor unit stops and restarts 3 minutes later is repeated.	7-time blink / 2.5 seconds OFF	Temperature of discharge temperature	Temperature of discharge temperature thermistor has been 122 °F [50 °C] or less for 20 minutes.	<ul style="list-style-type: none"> Check refrigerant circuit and refrigerant amount. Refer to "10-5.⑥ Check of LEV". 	<ul style="list-style-type: none"> Check if indoor filters are clogged. Check if refrigerant is short. Check if indoor/outdoor unit air circulation is short cycled. 	7-time blink / 2.5 seconds OFF	Temperature of discharge temperature	Temperature of discharge temperature thermistor has been 122 °F [50 °C] or less for 20 minutes.
15	Outdoor unit stops and restarts 3 minutes later is repeated.	8-time blink / 2.5 seconds OFF	Temperature of discharge temperature	Temperature of discharge temperature thermistor has been 122 °F [50 °C] or less for 20 minutes.	<ul style="list-style-type: none"> Check refrigerant circuit and refrigerant amount. Refer to "10-5.⑥ Check of LEV". 	<ul style="list-style-type: none"> Check if indoor filters are clogged. Check if refrigerant is short. Check if indoor/outdoor unit air circulation is short cycled. 	8-time blink / 2.5 seconds OFF	Temperature of discharge temperature	Temperature of discharge temperature thermistor has been 122 °F [50 °C] or less for 20 minutes.
16	Outdoor unit stops and restarts 3 minutes later is repeated.	9-time blink / 2.5 seconds OFF	Temperature of discharge temperature	Temperature of discharge temperature thermistor has been 122 °F [50 °C] or less for 20 minutes.	<ul style="list-style-type: none"> Check refrigerant circuit and refrigerant amount. Refer to "10-5.⑥ Check of LEV". 	<ul style="list-style-type: none"> Check if indoor filters are clogged. Check if refrigerant is short. Check if indoor/outdoor unit air circulation is short cycled. 	9-time blink / 2.5 seconds OFF	Temperature of discharge temperature	Temperature of discharge temperature thermistor has been 122 °F [50 °C] or less for 20 minutes.
17	Outdoor unit stops and restarts 3 minutes later is repeated.	10-time blink / 2.5 seconds OFF	Temperature of discharge temperature	Temperature of discharge temperature thermistor has been 122 °F [50 °C] or less for 20 minutes.	<ul style="list-style-type: none"> Check refrigerant circuit and refrigerant amount. Refer to "10-5.⑥ Check of LEV". 	<ul style="list-style-type: none"> Check if indoor filters are clogged. Check if refrigerant is short. Check if indoor/outdoor unit air circulation is short cycled. 	10-time blink / 2.5 seconds OFF	Temperature of discharge temperature	Temperature of discharge temperature thermistor has been 122 °F [50 °C] or less for 20 minutes.
18	Outdoor unit stops and restarts 3 minutes later is repeated.	11-time blink / 2.5 seconds OFF	Temperature of discharge temperature	Temperature of discharge temperature thermistor has been 122 °F [50 °C] or less for 20 minutes.	<ul style="list-style-type: none"> Check refrigerant circuit and refrigerant amount. Refer to "10-5.⑥ Check of LEV". 	<ul style="list-style-type: none"> Check if indoor filters are clogged. Check if refrigerant is short. Check if indoor/outdoor unit air circulation is short cycled. 	11-time blink / 2.5 seconds OFF	Temperature of discharge temperature	Temperature of discharge temperature thermistor has been 122 °F [50 °C] or less for 20 minutes.
19	Outdoor unit stops and restarts 3 minutes later is repeated.	12-time blink / 2.5 seconds OFF	Temperature of discharge temperature	Temperature of discharge temperature thermistor has been 122 °F [50 °C] or less for 20 minutes.	<ul style="list-style-type: none"> Check refrigerant circuit and refrigerant amount. Refer to "10-5.⑥ Check of LEV". 	<ul style="list-style-type: none"> Check if indoor filters are clogged. Check if refrigerant is short. Check if indoor/outdoor unit air circulation is short cycled. 	12-time blink / 2.5 seconds OFF	Temperature of discharge temperature	Temperature of discharge temperature thermistor has been 122 °F [50 °C] or less for 20 minutes.
20	Outdoor unit stops and restarts 3 minutes later is repeated.	13-time blink / 2.5 seconds OFF	Temperature of discharge temperature	Temperature of discharge temperature thermistor has been 122 °F [50 °C] or less for 20 minutes.	<ul style="list-style-type: none"> Check refrigerant circuit and refrigerant amount. Refer to "10-5.⑥ Check of LEV". 	<ul style="list-style-type: none"> Check if indoor filters are clogged. Check if refrigerant is short. Check if indoor/outdoor unit air circulation is short cycled. 	13-time blink / 2.5 seconds OFF	Temperature of discharge temperature	Temperature of discharge temperature thermistor has been 122 °F [50 °C] or less for 20 minutes.

NOTE: 1. The location of LED is illustrated at the right figure. Refer to "10-6. TEST POINT DIAGRAM".

2. LED is lighted during normal operation.

The blinking frequency shows the number of times the LED blinks after every 2.5-second OFF. (Example) When the blinking frequency is "2".

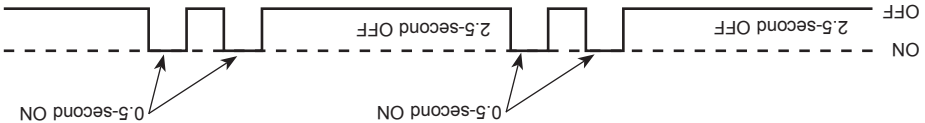

Inverter P.C. board

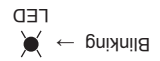

10-3. HOW TO PROCEED "SELF-DIAGNOSIS"

As this air conditioner has a function to memorize all the failures that had occurred, the latest failure detail can be recalled by following the procedure below. Use this function when the check code is not displayed with wired remote controller or the remote controller at use is wireless type.

10-3-1. Self-diagnosis <PAR-3xMAA ("x" represents 0 or later)>

① Select "Service" from the Main menu, and press the button.



Select "Self check" with the **F1** or **F2** button, and press the button.

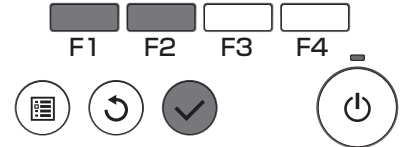
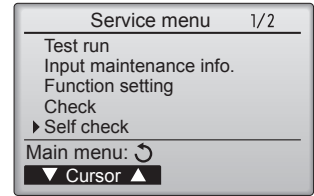

② With the **F1** or **F2** button, enter the refrigerant address, and press the button.

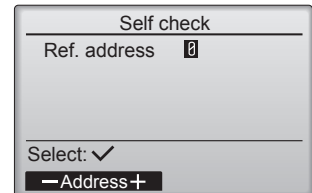

③ Check code, unit number, attribute will appear. "-" will appear if no error history is available.

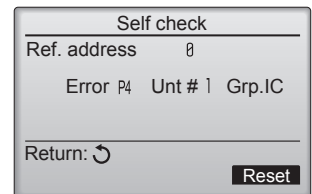

When there is no error history

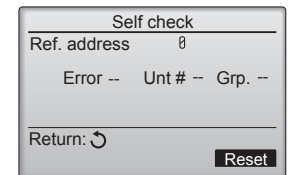

④ Resetting the error history.

Press the **F4** button (Reset) on the screen that shows the error history.



A confirmation screen will appear asking if you want to delete the error history.



Press the **F4** button (OK) to delete the error history.

If deletion fails, "Request rejected" will appear. "Unit not exist" will appear if no indoor units that are correspond to the entered address are found.

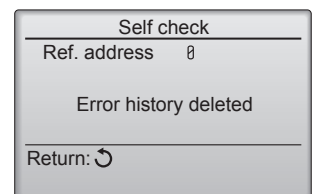
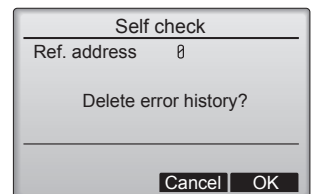



Navigating through the screens

- To go back to the Service menu button
- To return to the previous screen button

10-3-2. Remote controller check <PAR-3xMAA ("x" represents 0 or later)>



If operations cannot be completed with the remote controller, diagnose the remote controller with this function.

- ① Select "Service" from the Main menu, and press the  button.

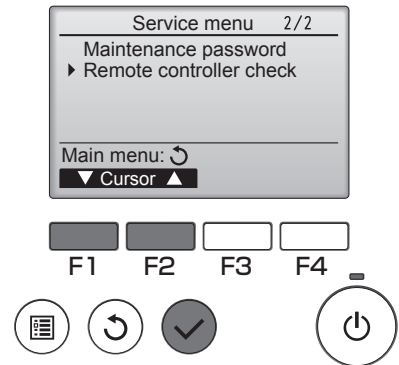
Select "Remote controller check" with the **F1** or **F2** button, and press the  button.



- ② Select "Remote controller check" from the Service menu, and press the  button to start the remote controller check and see the check results.

To cancel the remote controller check and exit the Remote controller check menu screen, press the  or the  button.

The remote controller will not reboot itself.

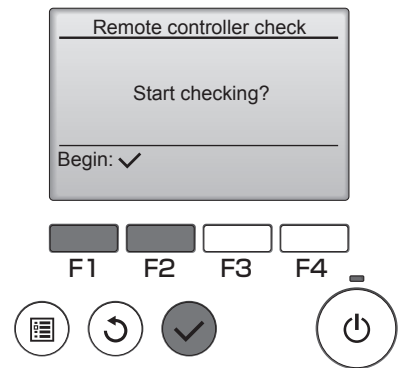

- ③
- OK: No problems are found with the remote controller. Check other parts for problems.
 - E3, 6832: There is noise on the transmission line, or the indoor unit or another remote controller is faulty. Check the transmission line and the other remote controllers.
 - NG (ALL0, ALL1): Send-receive circuit fault. Remote controller needs replacing.
 - ERC: The number of data errors is the discrepancy between the number of bits in the data transmitted from the remote controller and that of the data that was actually transmitted over the transmission line. If data errors are found, check the transmission line for external noise interference.

If the  button is pressed after the remote controller check results are displayed, remote controller check will end, and the remote controller will automatically reboot itself.

Remote controller check results screen

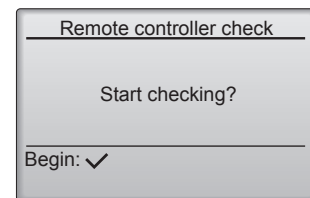

Check the remote controller display and see if anything is displayed (including lines). Nothing will appear on the remote controller display if the correct voltage (8.5–2 V DC) is not supplied to the remote controller. If this is the case, check the remote controller wiring and indoor units.

10-3-3. Self-diagnosis <Wireless remote controller>

<In case of trouble during operation>

When a malfunction occurs to air conditioner, both indoor unit and outdoor unit will stop and operation lamp blinks to inform unusual stop.

<Malfunction-diagnosis method at maintenance service>

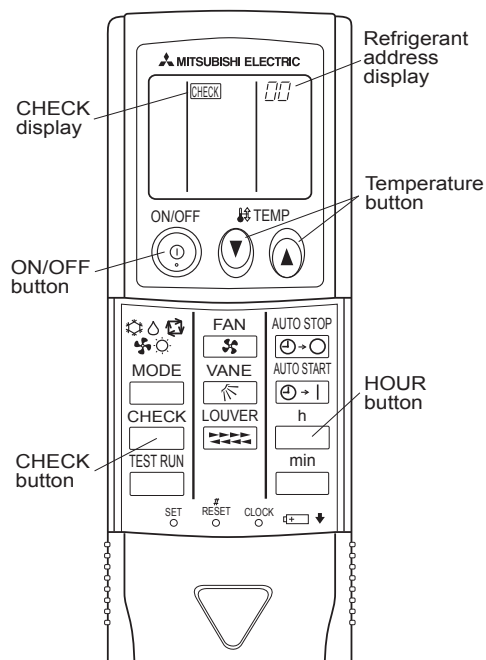

[Procedure]

1. Press the CHECK button twice.
 - "CHECK" lights, and refrigerant address "00" blinks.
 - Check that the remote controller's display has stopped before continuing.
2. Press the temperature buttons.
 - Select the refrigerant address of the indoor unit for the self-diagnosis.
 - Note: Set refrigerant address using the outdoor unit's DIP switch (SW1).
(For more information, see the outdoor unit installation manual.)
3. Point the remote controller at the sensor on the indoor unit and press the HOUR button.
 - If an air conditioner error occurs, the indoor unit's sensor emits an intermittent buzzer sound, the operation light blinks, and the check code is output.
(It takes 3 seconds at most for check code to appear.)
4. Point the remote controller at the sensor on the indoor unit and press the ON/OFF button.
 - The check mode is cancelled.

• Refer to the following tables for details on the check codes.

[Output pattern A]

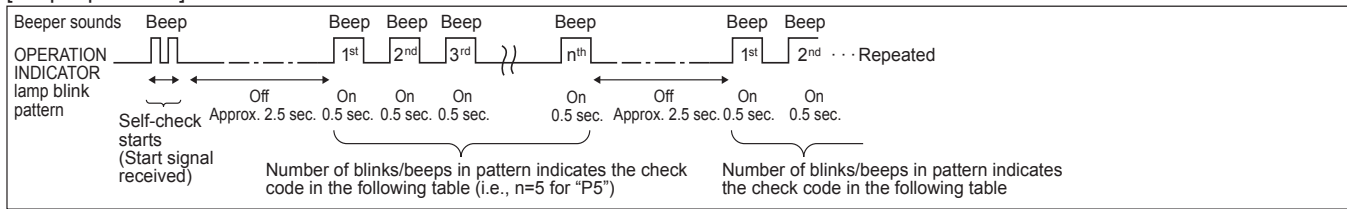

[Output pattern B]

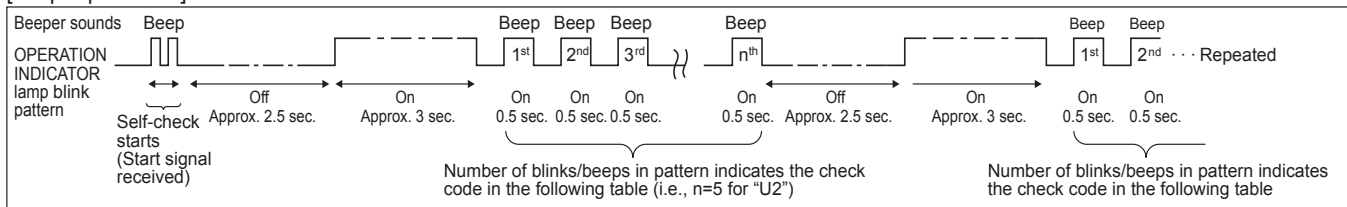

[Output pattern A] Errors detected by indoor unit

Wireless remote controller Beeper sounds/OPERATION INDICATOR lamp blinks (Number of times)	Wired remote controller Check code	Symptom	Remark
1	P1	Intake sensor error	As for indoor unit, refer to indoor unit's service manual.
2	P2	Pipe (TH2) sensor error	
	P9	Pipe (TH5) sensor error	
3	E6, E7	Indoor/outdoor unit communication error	
4	P4	Drain sensor error/Float switch connector (CN4F) open	
5	P5	Drain pump error	
	PA	Forced compressor stop (due to water leakage abnormality)	
6	P6	Freezing/Overheating protection operation	
7	EE	Communication error between indoor and outdoor units	
9	E4, E5	Remote controller signal receiving error	
12	Fb (FB)*	Indoor unit control system error (memory error, etc.)	
14	PL	Abnormality of refrigerant circuit	
–	E0, E3	Remote controller transmission error	
–	E1, E2	Remote controller control board error	

[Output pattern B] Errors detected by unit other than indoor unit (outdoor unit, etc.)

Wireless remote controller Beeper sounds/OPERATION INDICATOR lamp blinks (Number of times)	Wired remote controller Check code	Symptom
1	E9	Indoor/outdoor unit communication error (Transmitting error) (Outdoor unit)
2	UP	Compressor overcurrent interruption
3	U3, U4	Open/short of outdoor unit thermistors
14	Others	Other errors (Refer to the technical manual for the outdoor unit.)

Notes: 1. If the beeper does not sound again after the initial 2 beeps to confirm the self-check start signal was received and the OPERATION INDICATOR lamp does not come on, there are no error records.

2. If the beeper sounds 3 times continuously “beep, beep, beep (0.4 + 0.4 + 0.4 sec.)” after the initial 2 beeps to confirm the self-check start signal was received, the specified refrigerant address is incorrect.

*The check code in the parenthesis indicates PAR-30MAA model.

10-4. TROUBLE CRITERION OF MAIN PARTS

SUZ-KA18NA(H)2.TH SUZ-KA24NA(H)2.TH SUZ-KA30NA(H)2.TH SUZ-KA36NA(H)2.TH

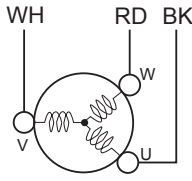
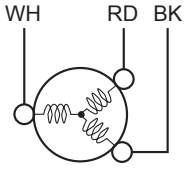
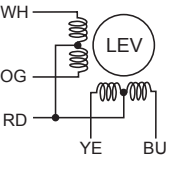
Part name	Check method and criterion	Figure										
Defrost thermistor (RT61) Fin temperature thermistor (RT64) Ambient temperature thermistor (RT65) Outdoor heat exchanger temperature thermistor (RT68)	Measure the resistance with a tester. Refer to "Inverter P.C. board" in "10-6. TEST POINT DIAGRAM AND VOLTAGE", for the chart of thermistor.											
Discharge temperature thermistor (RT62)	Measure the resistance with a tester. Before measurement, hold the thermistor with your hands to warm it up. Refer to "Inverter P.C. board" in "10-6. TEST POINT DIAGRAM AND VOLTAGE", for the chart of thermistor.											
Compressor	Measure the resistance between terminals with a tester. (Temperature: 14 to 104 °F (-10 to 40 °C)) <table border="1" style="margin-left: 20px;"> <thead> <tr> <th rowspan="2"></th> <th colspan="2">Normal (Ω)</th> </tr> <tr> <th>KA18</th> <th>KA24/30/36</th> </tr> </thead> <tbody> <tr> <td>U-V</td> <td rowspan="3">0.82 to 1.11</td> <td rowspan="3">0.83 to 1.03</td> </tr> <tr> <td>U-W</td> </tr> <tr> <td>V-W</td> </tr> </tbody> </table>		Normal (Ω)		KA18	KA24/30/36	U-V	0.82 to 1.11	0.83 to 1.03	U-W	V-W	
	Normal (Ω)											
	KA18	KA24/30/36										
U-V	0.82 to 1.11	0.83 to 1.03										
U-W												
V-W												
Outdoor fan motor	Measure the resistance between lead wires with a tester. (Temperature: 14 ~ 104 °F (-10 ~ 40 °C)) <table border="1" style="margin-left: 20px;"> <thead> <tr> <th rowspan="2">Color of lead wire</th> <th colspan="2">Normal (Ω)</th> </tr> <tr> <th>KA18</th> <th>KA24/30/36</th> </tr> </thead> <tbody> <tr> <td>RD – BK</td> <td rowspan="3">12 to 16</td> <td rowspan="3">12 to 17</td> </tr> <tr> <td>BK – WH</td> </tr> <tr> <td>WH – RD</td> </tr> </tbody> </table>	Color of lead wire	Normal (Ω)		KA18	KA24/30/36	RD – BK	12 to 16	12 to 17	BK – WH	WH – RD	
Color of lead wire	Normal (Ω)											
	KA18	KA24/30/36										
RD – BK	12 to 16	12 to 17										
BK – WH												
WH – RD												
R. V. coil (21S4)	Measure the resistance with a tester. (Temperature: 14 to 104 °F (-10 to 40 °C)) <table border="1" style="margin-left: 20px;"> <thead> <tr> <th>Normal (kΩ)</th> </tr> </thead> <tbody> <tr> <td>0.97 to 1.38</td> </tr> </tbody> </table>	Normal (kΩ)	0.97 to 1.38									
Normal (kΩ)												
0.97 to 1.38												
Expansion valve coil (LEV)	Measure the resistance with a tester. (Temperature: 14 ~ 104 °F (-10 ~ 40 °C)) <table border="1" style="margin-left: 20px;"> <thead> <tr> <th>Color of lead wire</th> <th>Normal (Ω)</th> </tr> </thead> <tbody> <tr> <td>RD – OG</td> <td rowspan="5">37 to 54</td> </tr> <tr> <td>RD – WH</td> </tr> <tr> <td>RD – BU</td> </tr> <tr> <td>RD – YE</td> </tr> <tr> <td>RD – YE</td> </tr> </tbody> </table>	Color of lead wire	Normal (Ω)	RD – OG	37 to 54	RD – WH	RD – BU	RD – YE	RD – YE			
Color of lead wire	Normal (Ω)											
RD – OG	37 to 54											
RD – WH												
RD – BU												
RD – YE												
RD – YE												
Defrost heater (SUZ-KA-NAH2)	Measure the resistance using a tester. [Temperature: 14 - 104°F (-10 - 40°C)] <table border="1" style="margin-left: 20px;"> <thead> <tr> <th>Normal (kΩ)</th> </tr> </thead> <tbody> <tr> <td>349 to 428</td> </tr> </tbody> </table>	Normal (kΩ)	349 to 428									
Normal (kΩ)												
349 to 428												

10-5. TROUBLESHOOTING FLOW

A How to check inverter/compressor

Disconnect the connector (CN61) between compressor and the intelligent power module (IPM).

Check the voltage between terminals.

.....See 10-5.ⓑ “Check of open phase”.

Are the voltages balanced?

No

Replace the inverter P.C. board.

Yes

Check the compressor.

.....See 10-5.ⓒ “Check of compressor”.

B Check of open phase

- With the connector between the compressor and the intelligent power module disconnected, activate the inverter and check if the inverter is normal by measuring the voltage balance between the terminals.

Output voltage is 50 - 130 V. (The voltage may differ according to the tester.)

<Operation method (Test run operation)>

1. Press the TEST (RUN) button twice.
2. Press the MODE button and switch to the COOL (or HEAT) mode.
3. Compressor starts at rated frequency in COOL mode or 58 Hz in HEAT mode.
4. Indoor fan operates at High speed.
5. To cancel test run operation, press the ON/OFF button on remote controller.

<Measurement point>

at 3 points

BK (U) - WH (V)

BK (U) - RD (W)

WH(V) - RD (W)

Measure AC voltage between the lead wires at 3 points.

NOTE: 1. Output voltage varies according to power supply voltage.

2. Measure the voltage by analog type tester.

3. During this check, LED of the inverter P.C. board blinks 9 times.
(Refer to "10-6. TEST POINT DIAGRAM AND VOLTAGE".)

C Check of compressor

Refer to 10-5.ⓓ “Check of compressor winding”.

Is the compressor normal?

No

Replace the compressor.

Yes

Refer to 10-5.ⓔ “Check of compressor operation time”.

Does the compressor operate continuously?

No

Refer to 10-5.ⓕ “Check of compressor start failure”.

Yes

OK.

D Check of compressor winding

- Disconnect the connector between the compressor and intelligent power module, and measure the resistance between the compressor terminals.

<Measurement point>

Measure the resistance between the lead wires at 3 points.

BK - WH

BK - RD

WH - RD

<Judgement>

Refer to "10-4. TROUBLE CRITERION OF MAIN PARTS".

0[Ω] Abnormal [short]

Infinite [Ω] Abnormal [open]

NOTE: Be sure to zero the ohmmeter before measurement.

E Check of compressor operation time

- Connect the compressor and activate the inverter. Then measure the time until the inverter stops due to over current.

<Operation method>

Start heating or cooling operation by pressing the TEST button twice on the remote controller. (Test run mode)
(TEST RUN OPERATION: Refer to 10-5 ⑥.)

<Measurement>

Measure the time from the start of compressor to the stop of compressor due to overcurrent.

<<Judgement>>

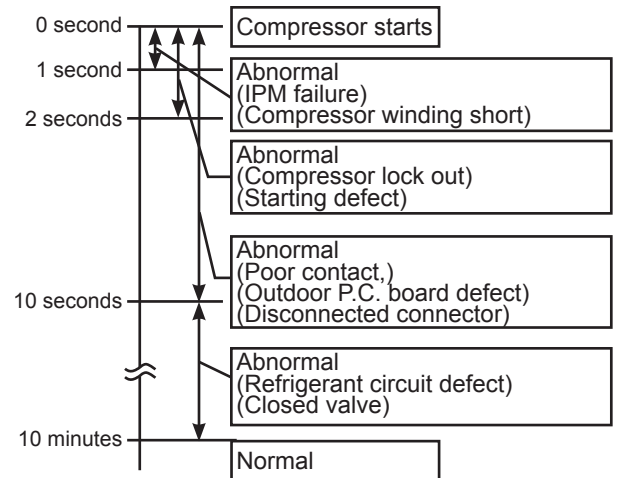

F Check of compressor start failure

Confirm that 1~4 is normal.

- Electrical circuit check
 1. Contact of the compressor connector
 2. Output voltage of inverter P.C. board and balance of them (See 10-5.⑥)
 3. Direct current voltage between DB61(+) and (-) on the inverter P.C. board
 4. Voltage between outdoor terminal block S1-S2

Does the compressor run for 10 seconds or more after it starts?

Yes

Check the refrigerant circuit.
Check the stop valve.

No

After the compressor is heated with a drier, does the compressor start?*1

No

Replace the compressor.

Yes

Compressor start failure. Activate pre-heat control.
(Refer to "9-2. PRE-HEAT CONTROL SETTING")

WARNING:

When opening or closing the valve below freezing temperatures, refrigerant may spurt out from the gap between the valve stem and the valve body, resulting in injuries.

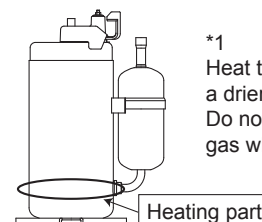

*1
Heat the compressor with a drier for about 20 minutes. Do not recover refrigerant gas while heating.

G Check of outdoor thermistors

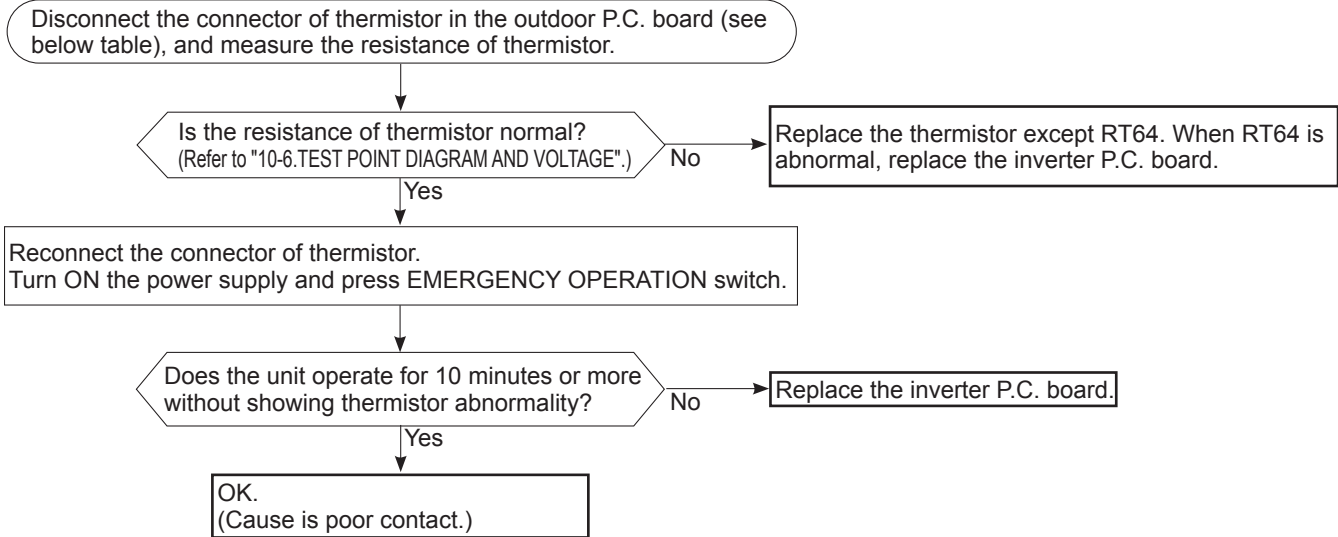

Thermistor	Symbol	Connector, Pin No.		Board
		SUZ-KA18NA2	SUZ-KA24/30/36NA2	
Defrost	RT61	Between CN641 pin1 and pin2	Between CN671 pin1 and pin2	Inverter P.C. board
Discharge temperature	RT62	Between CN641 pin3 and pin4	Between CN671 pin3 and pin4	
Fin temperature	RT64	Between CN642 pin1 and pin2	Between CN673 pin1 and pin2	
Ambient temperature	RT65	Between CN643 pin1 and pin2	Between CN672 pin1 and pin2	
Outdoor heat exchanger temperature	RT68	Between CN644 pin1 and pin3	Between CN671 pin5 and pin6	

H Check of R.V. coil

First of all, measure the resistance of R.V. coil to check if the coil is defective. Refer to "10-4. TROUBLE CRITERION OF MAIN PARTS".
In case CN721 is disconnected or R.V. coil is open, voltage is generated between the terminal pins of the connector although no signal is being transmitted to R.V. coil. Check if CN721 is connected.

Unit operates in COOL mode even if it is set to HEAT mode.

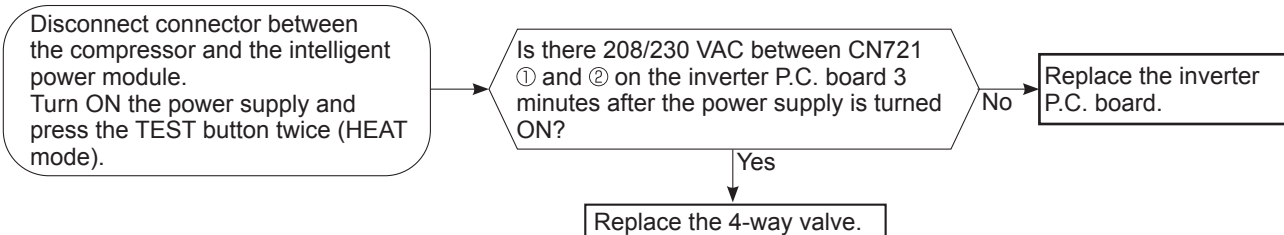

Unit operates in HEAT mode even if it is set to COOL mode.

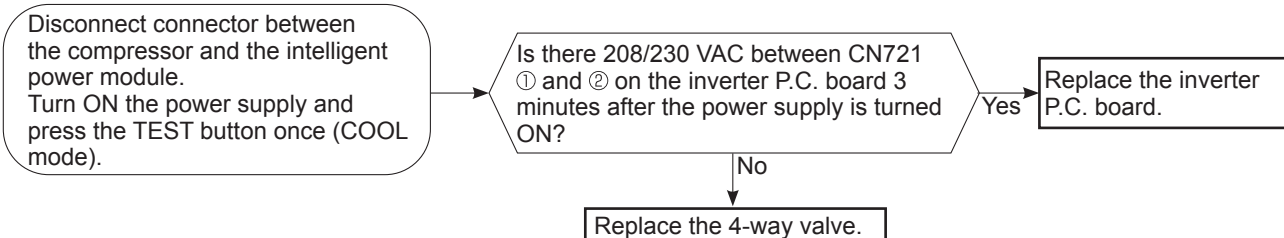

① Check of outdoor fan motor

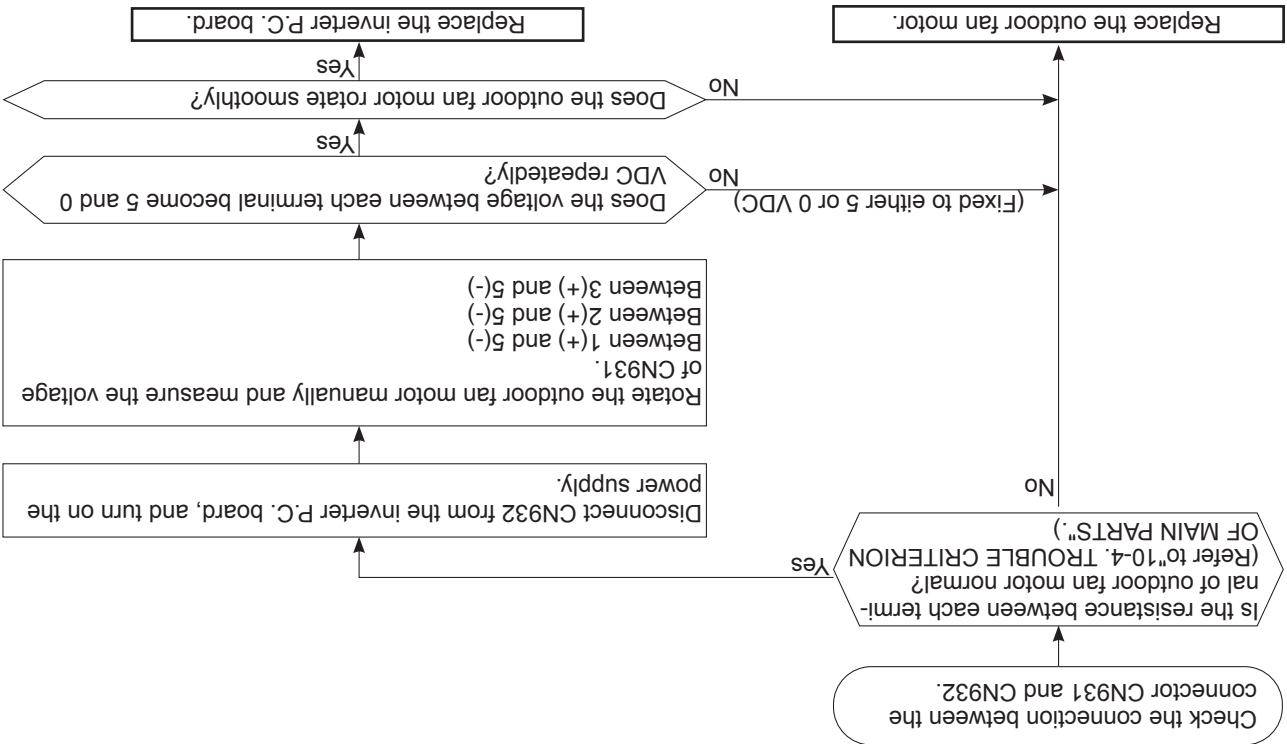

② Check of power supply

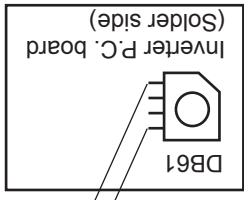
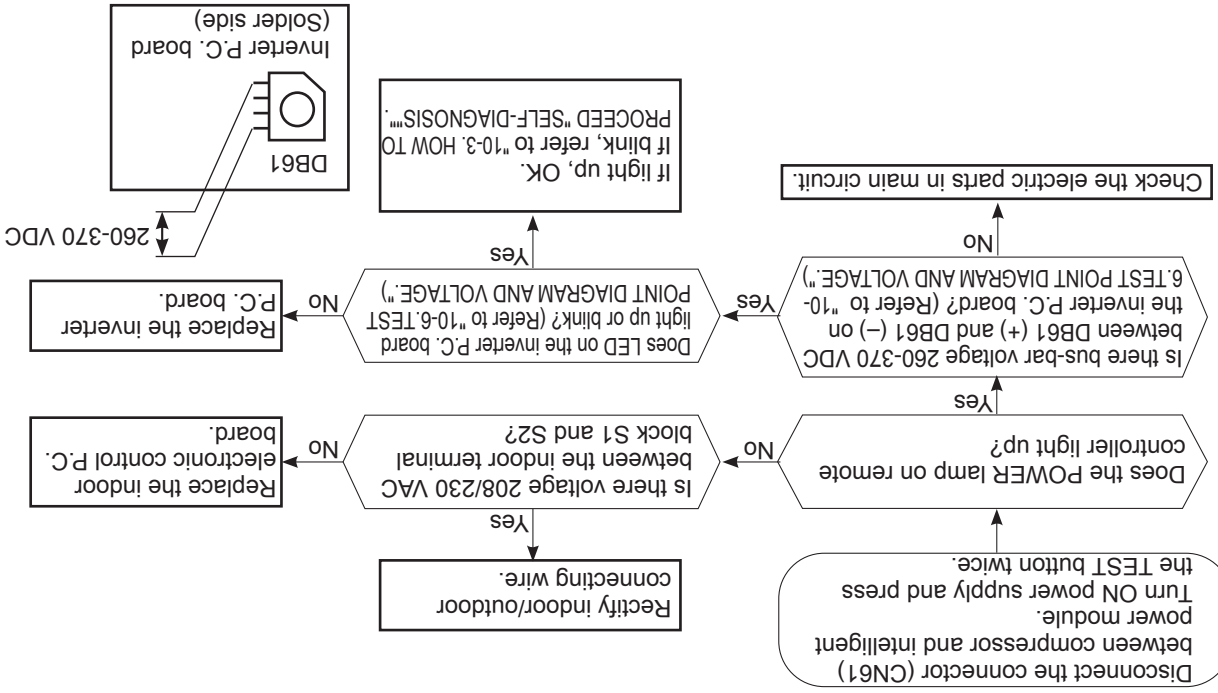

260-370 VDC

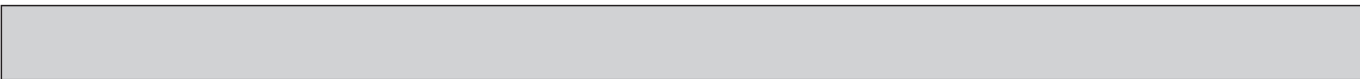

K Check of LEV

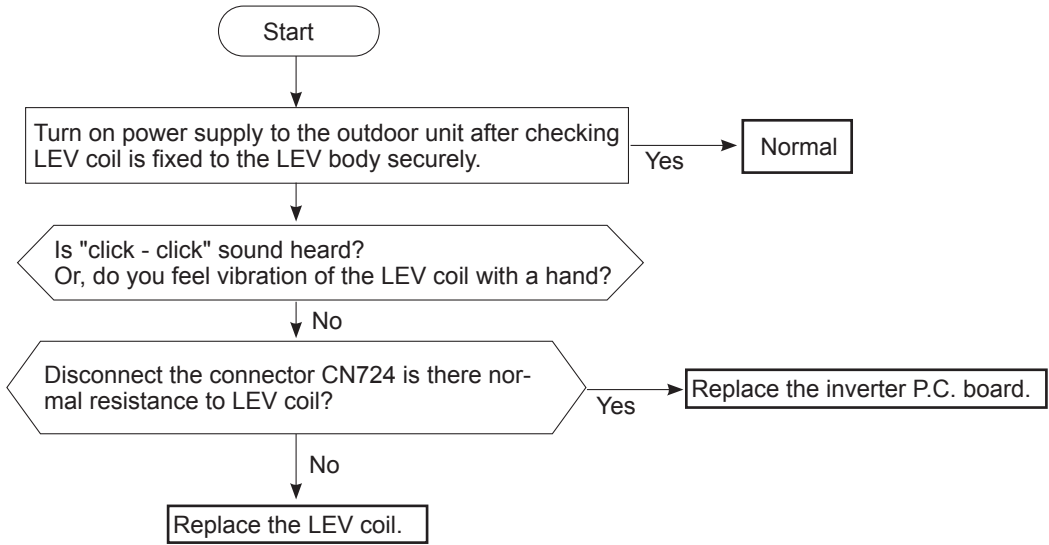

L Check of inverter P.C. board

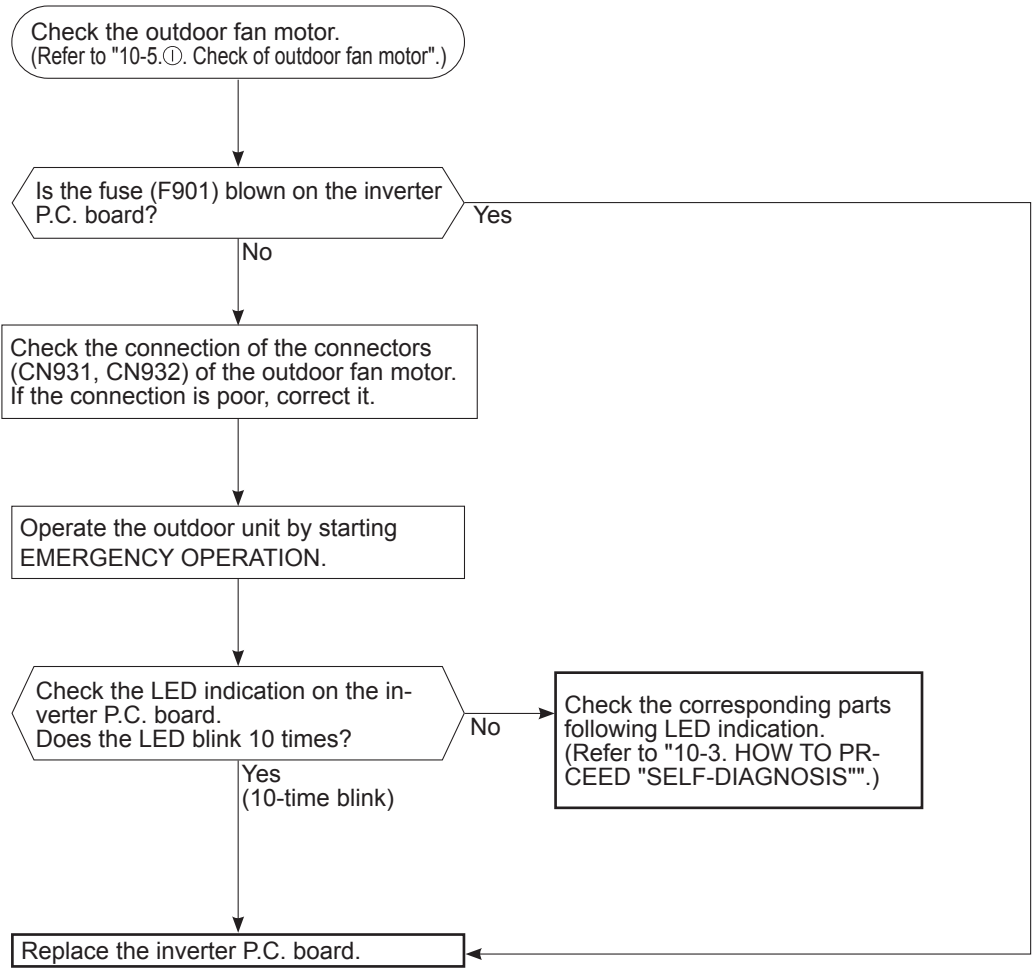

M How to check miswiring and serial signal error

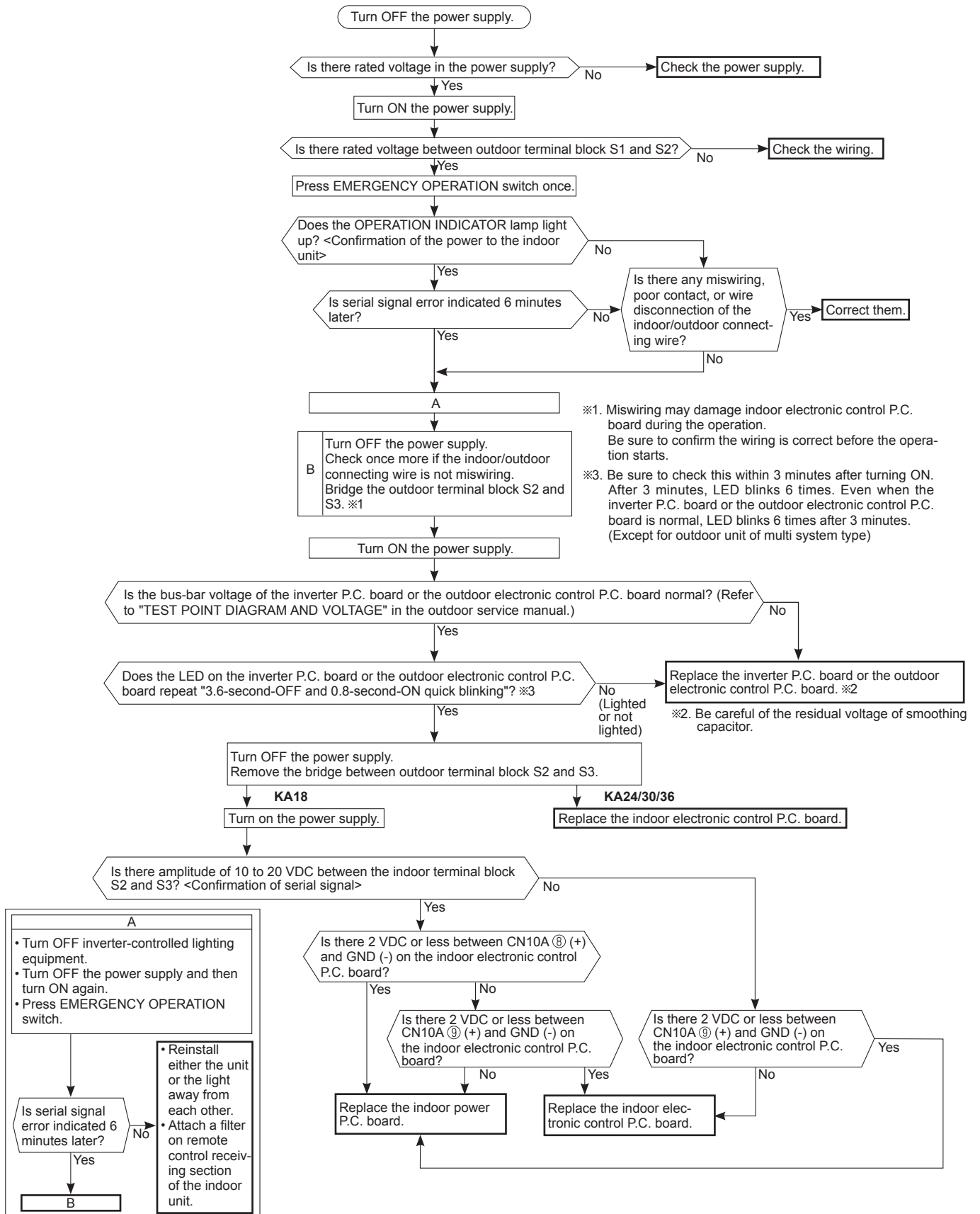

Ⓝ Check the defrost heater (base pan heater)

SUZ-KA18/24/30/36NAH2

Check the following points before checking electric continuity.

1. Does the resistance of ambient temperature thermistor have the characteristics? Refer to 10-6.1.
2. Is the resistance of defrost heater normal? Refer to 10-4.
3. Does the heater protector remain conducted (not open)?
4. Are both ambient temperature thermistor and circuit of defrost heater securely connected to connectors?

In HEAT mode, for more than 5 minutes, let the ambient temperature thermistor continue to read 32°F (0°C) or below, and let the defrost thermistor continue to read 30°F (-1°C) or below.

NOTE: In case both thermistors are more than the above temperature, cool them with cold water etc...

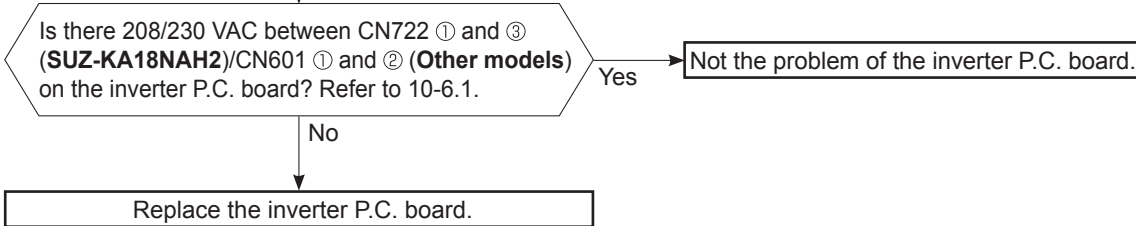

Ⓞ Check of outdoor refrigerant circuit

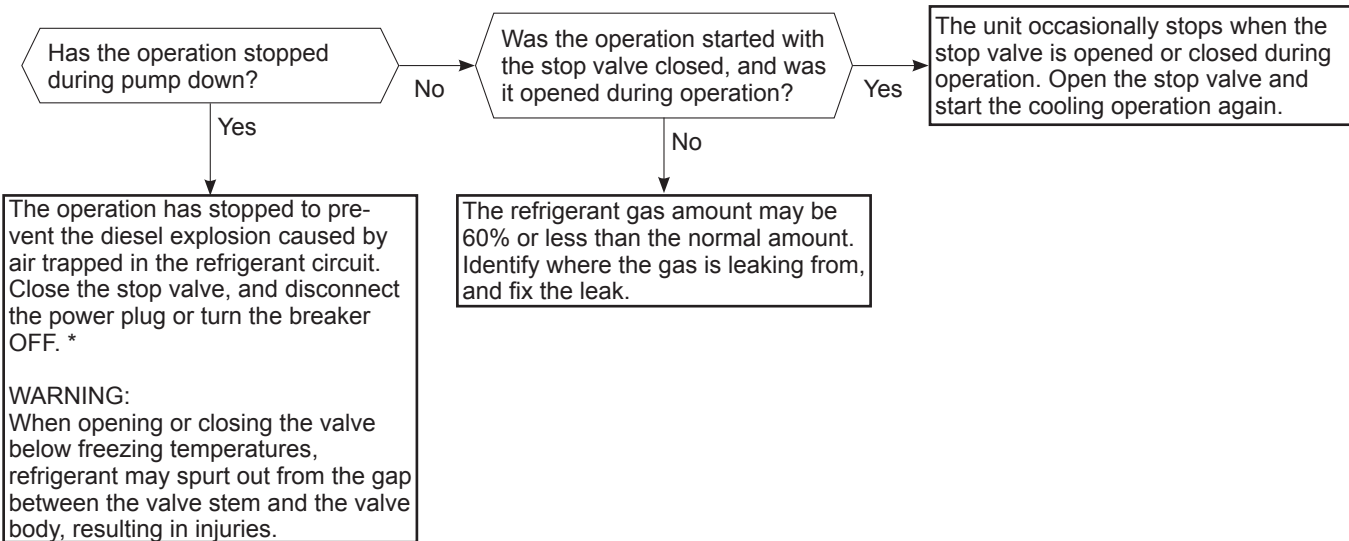

* **CAUTION** : Do not start the operation again to prevent hazards.

P Electromagnetic noise enters into TV sets or radios

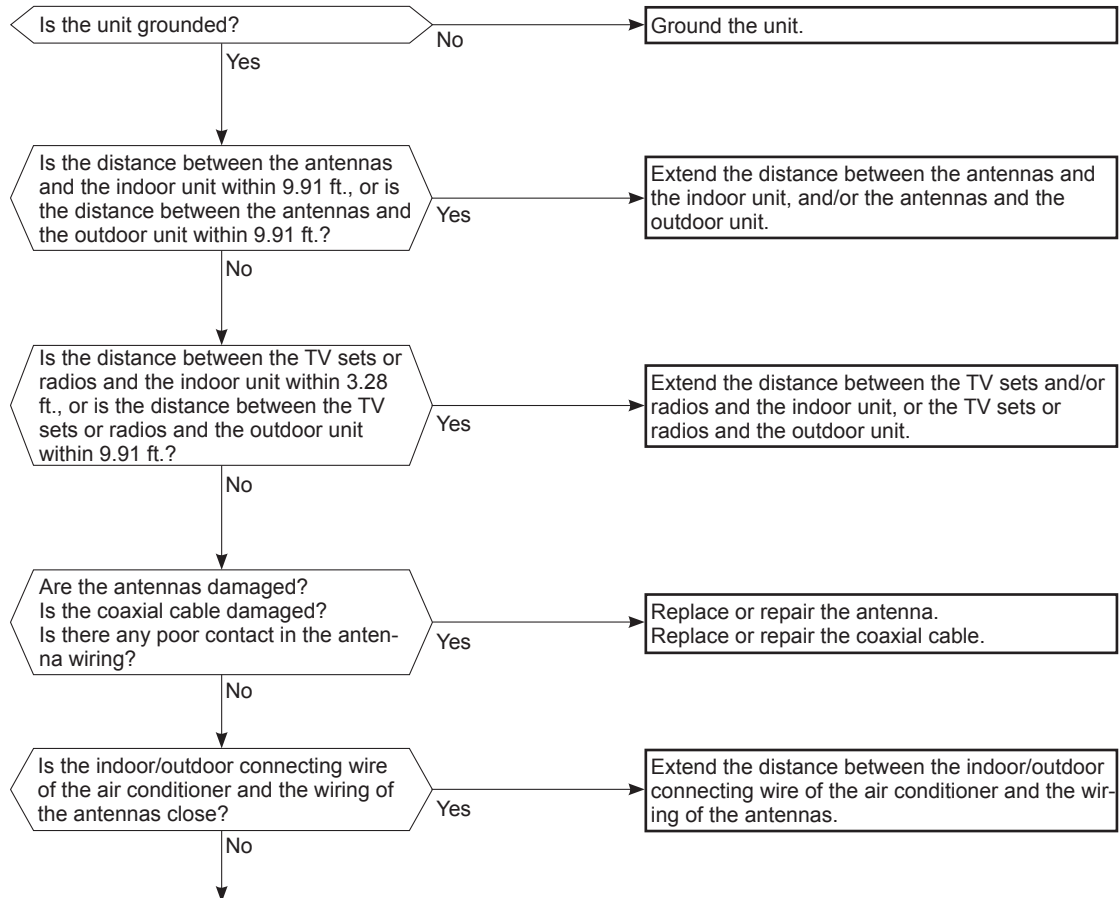

Even if all of the above conditions are fulfilled, the electromagnetic noise may enter, depending on the electric field strength or the installation condition (combination of specific conditions such as antennas or wiring). Check the followings before asking for service.

1. Devices affected by the electromagnetic noise
TV sets, radios (FM/AM broadcast, shortwave)
2. Channel, frequency, broadcast station affected by the electromagnetic noise
3. Channel, frequency, broadcast station unaffected by the electromagnetic noise
4. Layout of:
indoor/outdoor unit of the air conditioner, indoor/outdoor wiring, grounding wire, antennas, wiring from antennas, receiver
5. Electric field intensity of the broadcast station affected by the electromagnetic noise
6. Presence or absence of amplifier such as booster
7. Operation condition of air conditioner when the electromagnetic noise enters in
 - 1) Turn OFF the power supply once, and then turn ON the power supply. In this situation, check for the electromagnetic noise.
 - 2) Within 3 minutes after turning ON the power supply, press OPERATE/STOP (ON/OFF) button on the remote controller for power ON, and check for the electromagnetic noise.
 - 3) After a short time (3 minutes later after turning ON), the outdoor unit starts running. During operation, check for the electromagnetic noise.
 - 4) Press OPERATE/STOP (ON/OFF) button on the remote controller for power OFF, when the outdoor unit stops but the indoor/outdoor communication still runs on. In this situation, check for the electromagnetic noise.

10-6. TEST POINT DIAGRAM AND VOLTAGE

Inverter P.C. board

SUZ-KA18NA(H)2.TH

Back side of unit

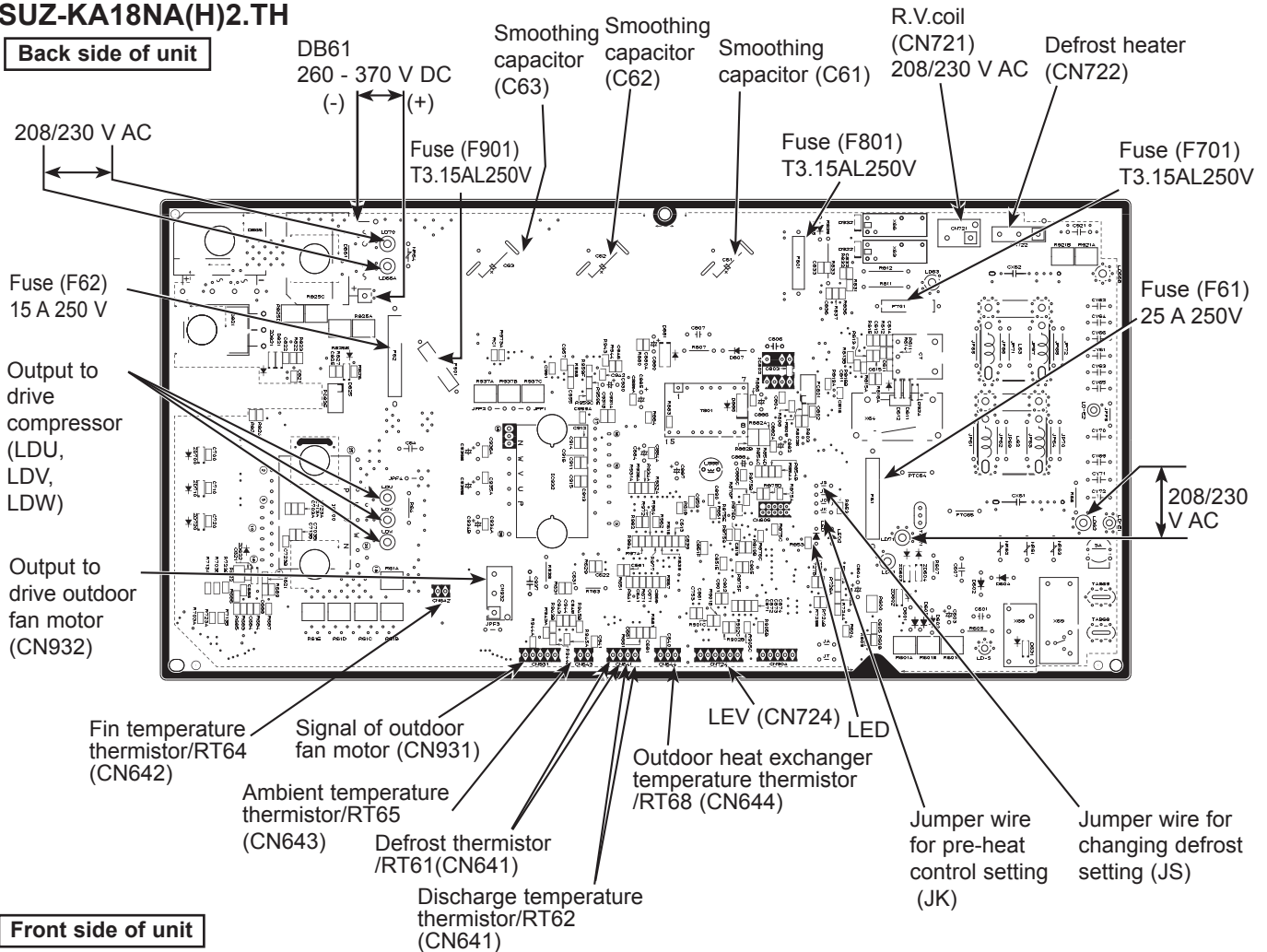

Front side of unit

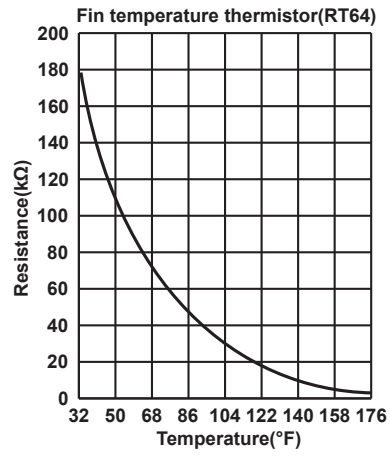
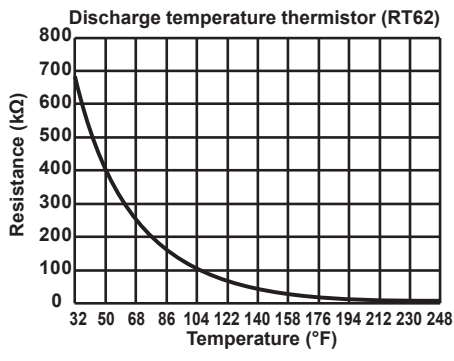
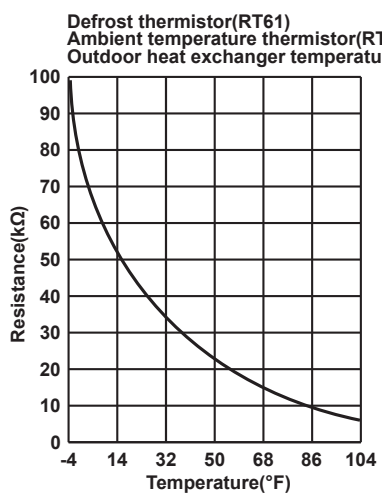

SUZ-KA24NA(H)2.TH

SUZ-KA30NA(H)2.TH

SUZ-KA36NA(H)2.TH

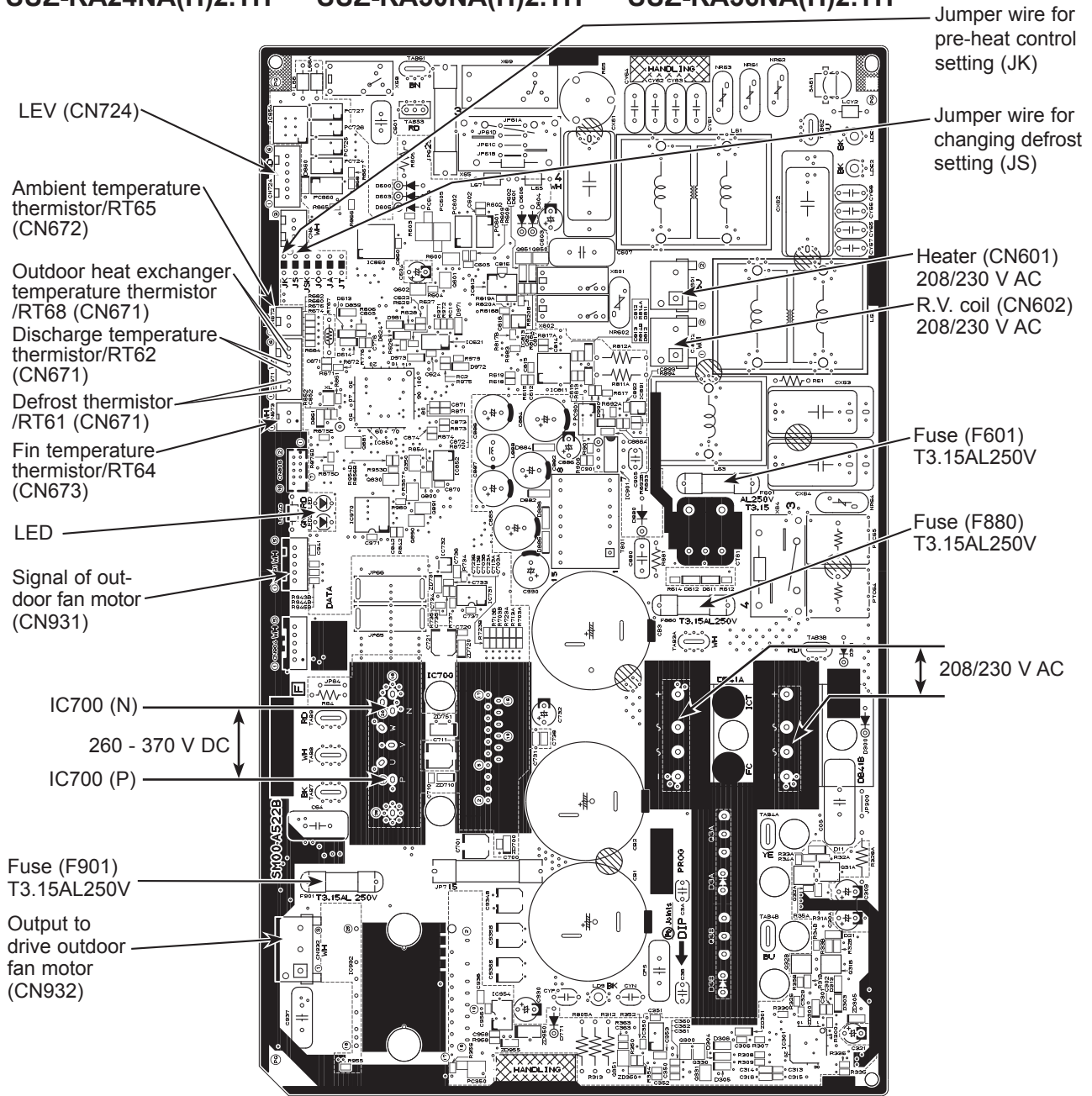

Defrost thermistor(RT61)
Ambient temperature thermistor(RT65)
Outdoor heat exchanger temperature thermistor(RT68)

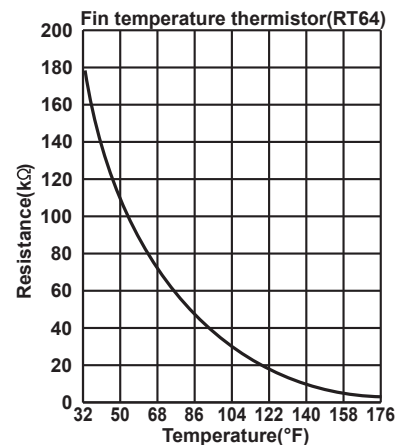
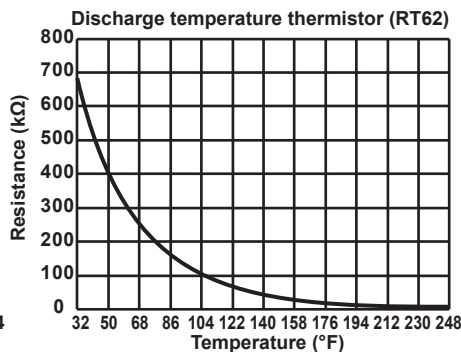
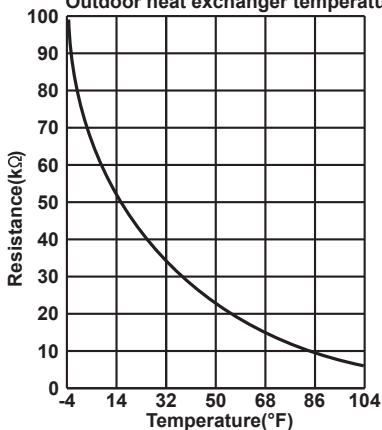

11-1. UNIT FUNCTION SETTING BY THE REMOTE CONTROLLER

Each function can be set according to necessity using the remote controller. The setting of function for each unit can only be done by the remote controller. Select function available from the table 1.

<Table 1> Function selections

(1) Functions available when setting the unit number to 00 (Select 00 referring to ④ setting the indoor unit number.)

Function	Settings	Mode No.	Setting No.	● : Initial setting (when sent from the factory)	Check	Remarks
		Wired remote controller (RF thermostat)				
Power failure automatic recovery	Not available	01	1			The setting is applied to all the units in the same refrigerant system.
	Available (Approx. 4-minute wait-period after power is restored.)	(101)	2	●		
Indoor temperature detecting	Indoor unit's internal sensor	02	1	●		
	Data from main remote controller *1	(—)	2			
LOSSNAY connectivity	Not supported	03 (103)	3			
	Supported (indoor unit dose not intake outdoor air through LOSSNAY)		1	●		
	Supported (indoor unit intakes outdoor air through LOSSNAY)		2			
Power supply voltage	230V	04	1	●		
	208V	(104)	2			
Frost prevention temperature	2°C [36°F] (Normal)	15	1	●		
	3°C [37°F]	(115)	2			

*1 Can be set only when a wired remote controller is used.

When using 2 remote controllers (2-remote controller operation), the remote controller with built-in sensor must be set as a main remote controller.

(2) Functions are available when setting the unit number to 01.

Function	Settings	Mode No. Wired remote controller (RF thermostat)	Setting No.	● : Initial setting (Factory setting)				Check
				Ceiling concealed	Ceiling cassette	Ceiling suspended	Multi position	
				SEZ-KD-NA4	SLZ-KA-NA	PEAD-A-AA	SVZ-KP-NA	
Filter sign	100h	07 (107)	1					
	2500h		2		●			
	No filter sign indicator		3	●		●	●	
External static pressure	5/15/35/50Pa (0.02/0.06/0.14/0.20in.WG)	08 (108)		Refer to the table below	—	Refer to the table below	Refer to the table below	
		10 (110)		Refer to the table below	—	Refer to the table below	Refer to the table below	
Heater control *2	No heater present	11 (111)	1	—	—	●	●	
	Heater present		2	—	—			
	SEZ, SLZ :Set temp -4.5°F ON PEAD, SVZ :Heater not operation in Defrost/Error	23 (123)	1	●	●	●	●	
	SEZ, SLZ :Set temp -1.8°F ON PEAD, SVZ :Heater not operation in Defrost/Error*4		2					
Set temperature in heating mode *3	Available	24 (124)	1	●	●	●	●	
	Not available		2					
Fan speed during the heating thermo OFF	Extra low	25 (125)	1	●	●	●	●	
	Stop		2					
	Set fan speed		3					
Fan speed during the cooling thermo OFF	Set fan speed	27 (127)	1	●	●	●	●	
	Stop		2					
Detection of abnormality of the pipe temperature (P8)	Available	28 (128)	1	●	●	●	●	
	Not available		2					

*2 For the detail of Heater control, refer to the service manual.

*3 4 degC (7.2 degF) up

*4 Depend on the error, heater may not operate please refer to SVZ service manual.

External static pressure setting for SEZ.

External static pressure	Setting No.		● : Initial setting (Factory setting)	Check
	Mode No. 08	Mode No. 10		
5Pa (0.02in.WG)	1	2		
15Pa (0.06in.WG)	1	1	●	
35Pa (0.14in.WG)	2	1		
50Pa (0.20in.WG)	3	1		

External static pressure setting for PEAD.

External static pressure	Setting No.		● : Initial setting (Factory setting)	Check
	Mode No. 08	Mode No. 10		
35Pa (0.14in.WG)	2	1		
50Pa (0.20in.WG)	3	1	●	
70Pa (0.28in.WG)	1	2		
100Pa (0.40in.WG)	2	2		
150Pa (0.60in.WG)	3	2		

External static pressure setting for SVZ (Vertical, Horizontal left, Horizontal right position*).

External static pressure	Setting No.		● : Initial setting (Factory setting)	Check
	Mode No. 08	Mode No. 10		
75Pa (0.3in.WG)	1	1		
125Pa (0.5in.WG)	2	1	●	
200Pa (0.8in.WG)	3	1		

* Regarding to down flow setting, please refer to down flow kit installation manual.

11-1-1. Selecting functions using the wired remote controller <PAR-3xMAA ("x" represents 0 or later)>

<Service menu>

Maintenance password is required

① Select "Service" from the Main menu, and press the  button.

*At the main display, the menu button and select "Service" to make the maintenance setting.

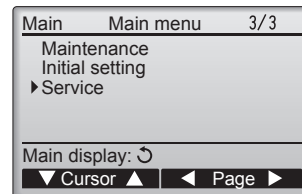

② When the Service menu is selected, a window will appear asking for the password.

To enter the current maintenance password (4 numerical digits), move the cursor to the digit you want to change with the **F1** or **F2** button.



Set each number (0 through 9) with the **F3** or **F4** button.



Then, press the  button.

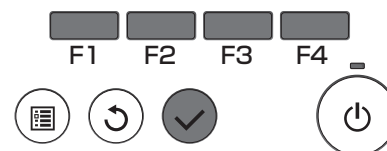
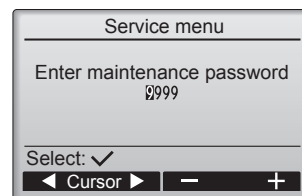

Note: The initial maintenance password is "9999". Change the default password as necessary to prevent unauthorized access. Have the password available for those who need it.

: If you forget your maintenance password, you can initialize the password to the default password "9999" by pressing and holding the **F1 and **F2** buttons simultaneously for three seconds on the maintenance password setting screen.**

③ If the password matches, the Service menu will appear.

The type of menu that appears depends on the connected indoor units' type.



Note: Air conditioning units may need to be stopped to make certain settings. There may be some settings that cannot be made when the system is centrally controlled.

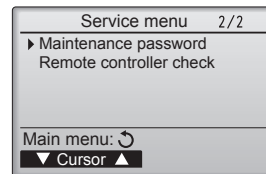
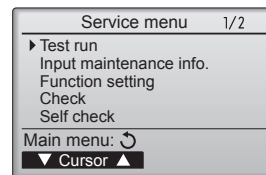

A screen will appear that indicates the setting has been saved.



Navigating through the screens

- To go back to the Main menu  button
- To return to the previous screen  button

<Function setting>

- ① Select "Service" from the Main menu, and press the  button.



Select "Function setting" with the **F1** or **F2** button, and press the  button.

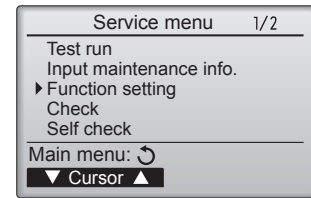

- ② Set the indoor unit refrigerant addresses and unit numbers with the **F1** through **F4** buttons, and then press the  button to confirm the current setting.

<Checking the indoor unit No.>

When the  button is pressed, the target indoor unit will start fan operation. If the unit is common or when running all units, all indoor units for the selected refrigerant address will start fan operation.

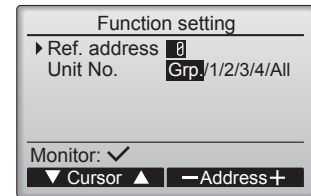

- ③ When data collection from the indoor units is completed, the current settings appears highlighted. Non-highlighted items indicate that no function settings are made. Screen appearance varies depending on the "Unit No." setting.

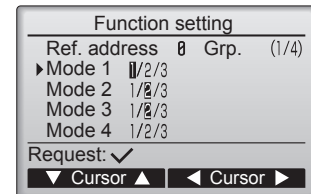

- ④ Use the **F1** or **F2** button to move the cursor to select the mode number, and change the setting number with the **F3** or **F4** button.

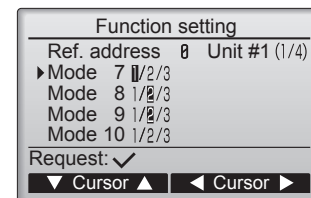

- ⑤ When the settings are completed, press the  button to send the setting data from the remote controller to the indoor units. When the transmission is successfully completed, the screen will return to the Function setting screen.

Note:

- Make the above settings only on Mr. Slim units as necessary.
- The above function settings are not available for the CITY MULTI units.
- Table 1 summarizes the setting options for each mode number. Refer to the indoor unit Installation Manual for the detailed information about initial settings, mode numbers, and setting numbers for the indoor units.
- Be sure to write down the settings for all functions if any of the initial settings has been changed after the completion of installation work.

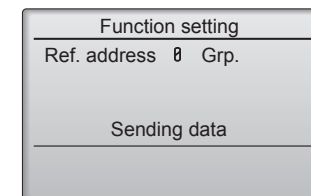

<"Terminal with locking mechanism" Detaching points>

The terminal which has the locking mechanism can be detached as shown below. There are two types (refer to (1) and (2)) of the terminal with locking mechanism. The terminal without locking mechanism can be detached by pulling it out. Check the shape of the terminal before detaching.

(1) Slide the sleeve and check if there is a locking lever or not.

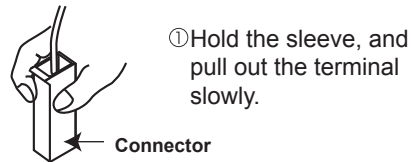
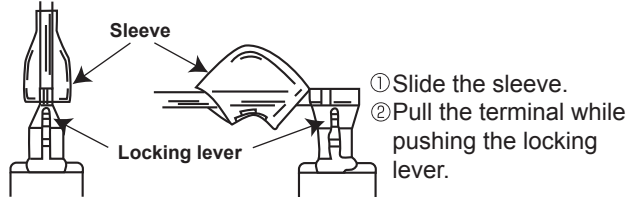

(2) The terminal with this connector has the locking mechanism.



SUZ-KA18NA(H)2.TH SUZ-KA24NA(H)2.TH SUZ-KA30NA(H)2.TH SUZ-KA36NA(H)2.TH

—————> : Indicates the visible parts in the photos/figures.
 - - - - -> : Indicates the invisible parts in the photos/figures.

NOTE: Turn OFF the power supply before disassembly.

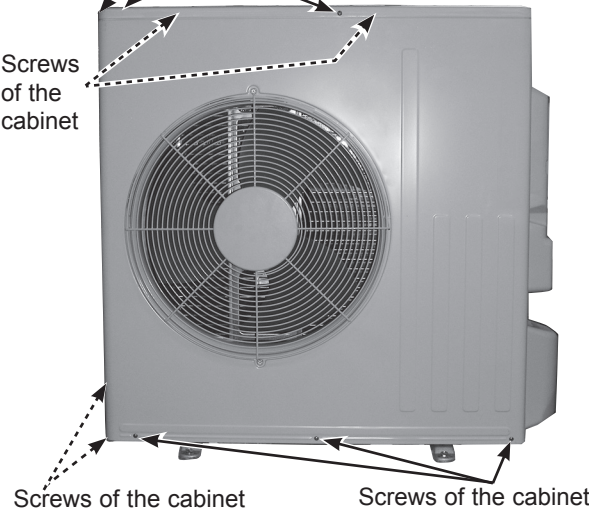
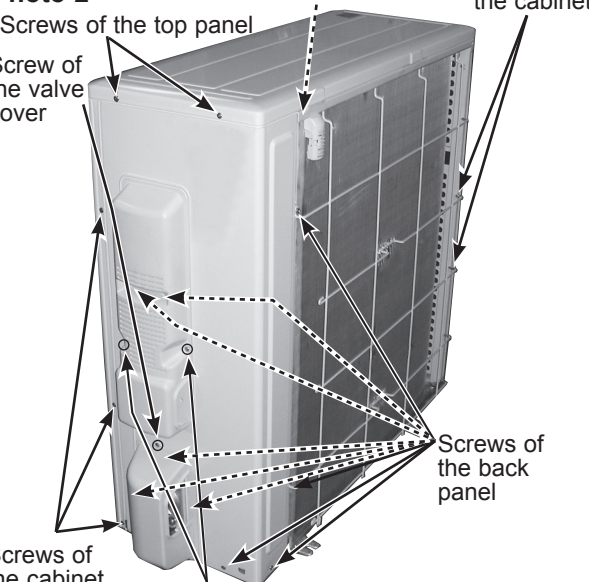
OPERATING PROCEDURE	PHOTOS/FIGURES
<p>1. Removing the cabinet</p> <ol style="list-style-type: none"> (1) Remove the screws of the service panel. (2) Remove the screws of the top panel. (3) Remove the screw of the valve cover. (4) Remove the service panel. (5) Remove the screws fixing the conduit cover. (6) Remove the conduit cover. (7) Remove the screw of fixing the conduit plate. (8) Remove the conduit plate. (9) Remove the top panel. (10) Remove the valve cover. (11) Disconnect the power supply and indoor/outdoor connecting wire. (12) Remove the screws of the cabinet. (13) Remove the cabinet. (14) Remove the screws of the back panel. (15) Remove the back panel. <p>Photo 3 Screws of the conduit cover</p>  <p>Photo 4 Screw of the conduit plate</p> 	<p>Photo 1 Screws of the top panel</p>  <p>Photo 2 Screws of the top panel</p> 

OPERATING PROCEDURE

2. Removing the inverter assembly, inverter P.C. board

- (1) Remove the cabinet and panels. (Refer to 1.)
- (2) Disconnect the lead wire to the reactor and the following connectors:
 - <Inverter P.C. board>
 - CN721 (R.V. coil)
 - CN722 (Defrost heater) (**SUZ-KA18NAH2**)
 - CN931, CN932 (Fan motor)
 - CN601(Defrost heater) (**SUZ-KA24/30/36NAH2**)
 - CN641 (Defrost thermistor and discharge temperature thermistor)
 - CN643 (Ambient temperature thermistor)
 - CN644 (Outdoor heat exchanger temperature thermistor)
 - CN724 (LEV)
- (3) Remove the compressor connector.
- (4) Remove the screw fixing the heat sink support and the separator.
- (5) Remove the fixing screws of the terminal block support and the back panel.
- (6) Remove the inverter assembly.
- (7) Remove the screw of the ground wire, screw of the P.C. board cover and screws of the terminal block support.
- (8) Remove the heat sink support from the P.C. board support.
- (9) Remove the screw of the inverter P.C. board and the inverter P.C. board from the P.C. board support.

3. Removing R.V. coil

- (1) Remove the cabinet and panels. (Refer to 1.)
- (2) Disconnect the following connector:
 - <Inverter P.C. board>
 - CN721 (R.V. coil)
- (3) Remove the R.V. coil.

Photo 7

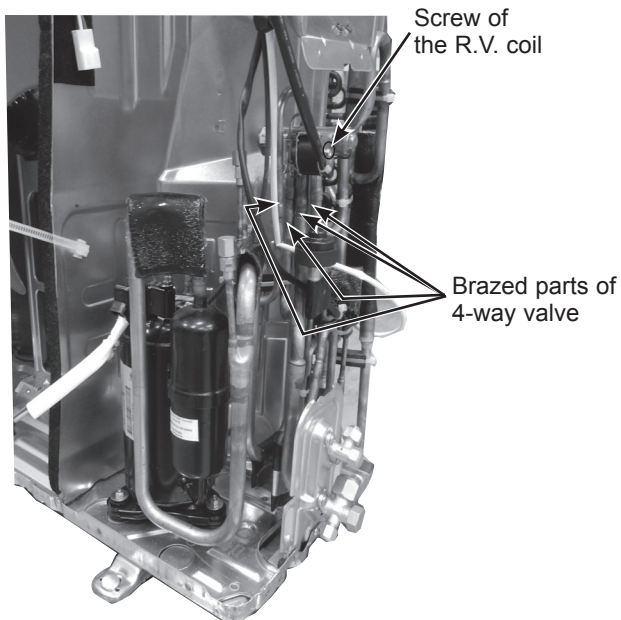

PHOTOS/FIGURES

Photo 5

Screw of the heat sink support and the separator

Screws of the terminal block support and the back panel

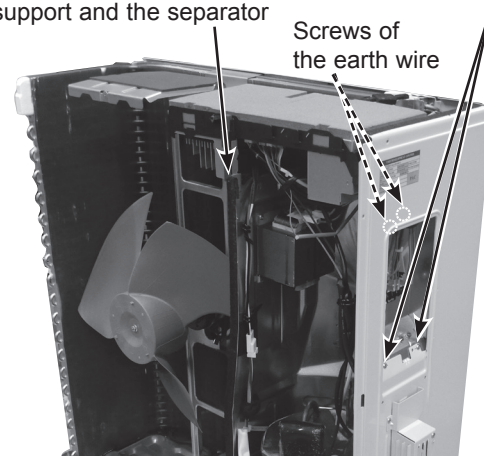
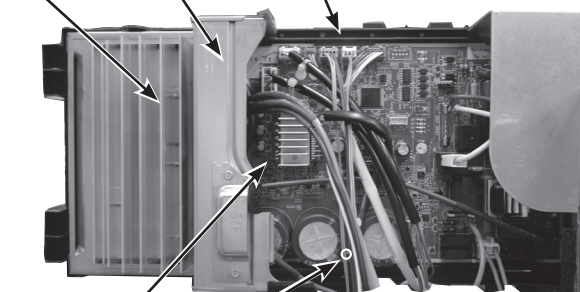

Photo 6-1 (KA18)

Heat sink support

Heat sink

P.C. board support



Inverter P.C. board

Screw of the inverter P.C. board

Photo 6-2 (KA24/30/36)

Inverter P.C. board

Screws of the relay panel

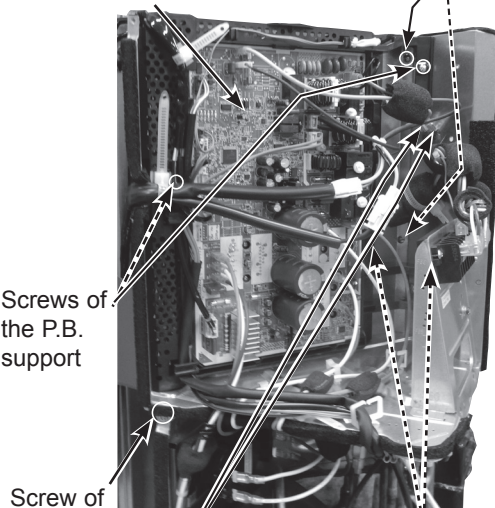

Screw of the relay panel

Earth wires

Screw of the P.B. support

OPERATING PROCEDURE

4. Removing the discharge temperature thermistor, defrost thermistor, outdoor heat exchanger temperature thermistor and ambient temperature thermistor

- (1) Remove the cabinet and panels. (Refer to 1.)
- (2) Disconnect the lead wire to the reactor and the following connectors:
<Inverter P.C. board>
CN641 (Defrost thermistor and discharge temperature thermistor)
CN643 (Ambient temperature thermistor)
CN644 (Outdoor heat exchanger temperature thermistor)
- (3) Pull out the discharge temperature thermistor from its holder.
- (4) Pull out the defrost thermistor from its holder.
- (5) Pull out the outdoor heat exchanger temperature thermistor from its holder.
- (6) Pull out the ambient temperature thermistor from its holder.

5. Removing outdoor fan motor

- (1) Remove the top panel, cabinet and service panel. (Refer to 1.)
- (2) Disconnect the following connectors:
<Inverter P.C. board>
CN931 and CN932 (Fan motor)
- (3) Remove the propeller fan nut.
- (4) Remove the propeller fan.
- (5) Remove the screws fixing the fan motor.
- (6) Remove the fan motor.

NOTE: The propeller fan nut is a revers thread.

6. Removing the compressor and 4-way valve

- (1) Remove the top panel, cabinet and service panel. (Refer to 1.)
- (2) Remove the back panel. (Refer to 1.)
- (3) Remove the inverter assembly. (Refer to 2.)
- (4) Recover gas from the refrigerant circuit.
NOTE: Recover gas from the pipes until the pressure gauge shows 0 PSIG.
- (5) Detach the brazed part of the suction and the discharge pipe connected with compressor.
- (6) Remove the compressor nuts.
- (7) Remove the compressor.
- (8) Detach the brazed part of 4-way valve and pipe. (Photo 7)

PHOTOS/FIGURES

Photo 8

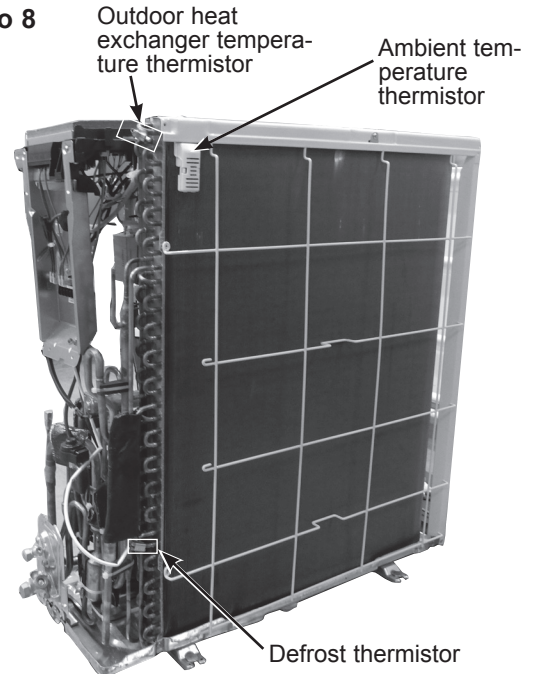

Photo 9

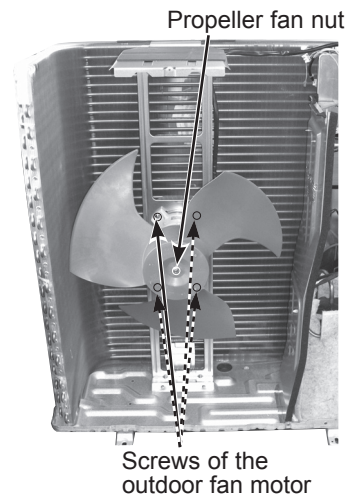
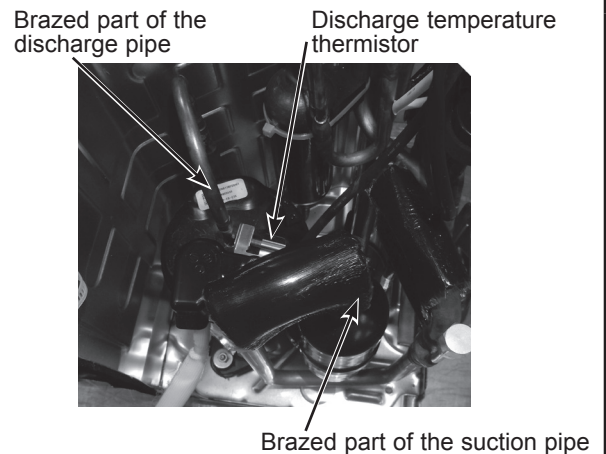

Photo 10



MITSUBISHI ELECTRIC CORPORATION

HEAD OFFICE : TOKYO BUILDING, 2-7-3, MARUNOUCHI, CHIYODA-KU, TOKYO 100-8310, JAPAN

©Copyright 2018 MITSUBISHI ELECTRIC CORPORATION
Issued: Jun. 2021 No. OCH688 REVISED EDITION-D
Issued: Aug. 2020 No. OCH688 REVISED EDITION-C
Issued: Feb. 2020 No. OCH688 REVISED EDITION-B
Issued: May 2019 No. OCH688 REVISED EDITION-A
Published : Nov. 2018 No.OCH688
Made in Japan

Specifications are subject to change without notice.