



Ojeda USA, Inc
460 Southport Commerce Blvd.
Spartanburg, SC 29306
864 574-6004 Fax 864 574-6005

INSTALLATION AND OPERATION MANUAL



NB28 NB34 NB43 NB51 NB60 NB68

Congratulations!
You have just purchased the finest commercial refrigeration available.

You have selected one of the finest commercial refrigeration units made. It is manufactured under strict quality controls with only the best quality materials available. Your Ojeda cooler, when installed correctly and properly maintained will give you many years of trouble-free operation.

Table of Contents

INSTALLATION AND OPERATION MANUAL.....	1
APPLICATION	3
DIRECTIONS FOR STORAGE AND HANDLING THE EQUIPMENT	3
STORAGE OF THE EQUIPMENT	3
UNCRATING	3
MOVING THE EQUIPMENT	4
PLACING AND INSTALLING THE EQUIPMENT	4
ENERGY SAVINGS IDEAS	4
ELECTRICAL REQUIREMENTS	5
PRODUCT LOADING.....	5
BASKET SPECIFICATIONS	5
UNIT OPERATION	6
POWER FAILURE/FREEZER FAILURE	6
SERVICE CHECKLIST	7
PRESCRIPTIONS, PROHIBITIONS AND OTHER USES FOR THE EQUIPMENT	8
MAINTENANCE GUIDELINES	9
REMOVAL OF FROST	9
CLEANING THE UNIT.....	9
LID REMOVAL	10

WARNING!

USE THIS APPLIANCE FOR ITS INTENDED PURPOSE AS DESCRIBED IN THIS MANUAL

When using electrical appliances, basic safety precautions should be followed, including the following:

- Use this appliance for its intended purpose as described in this Owner Manual.
- This freezer must be properly installed and located in accordance with the Installation Instructions.
- We strongly recommend that any servicing be performed by a qualified individual.
- Do not allow children to climb, stand, or hang on the shelves in the refrigerator.
- They could damage the refrigerator and seriously injure themselves.
- Do not store or use gasoline or other flammable vapors and liquids in the vicinity of this or any other appliance.
- Unplug the freezer before cleaning and making repairs



Warning Child Safety!

Destroy carton, plastic bags, and any exterior wrapping material immediately after the freezer is unpacked. Children should never use these items for play. Cartons covered with rugs, bedspreads, plastic sheets or stretch wrap may become airtight chambers and can quickly cause suffocation.

A child might suffocate if he crawls into a freezer to hide or play. Remove the door of a freezer when not in use, even if you plan to discard the freezer. Many communities have laws requiring you to take this safety precaution.

Remove and discard any spacers used to secure the shelves during shipping. Small objects are a choke hazard to children.

CAREFULLY READ THESE INSTRUCTIONS. This manual provides instructions in how to best locate, operate, and maintain this equipment.

It is recommended to keep this manual for any future reference.

Detailed Warranty Guidelines can be found on the Ojeda website.

APPLICATION

The CHP series of freezers have a sanitation listing permitting the merchandising of packaged food product.

PRODUCT REGISTRATION

Write down the Serial number of your new unit for future reference. The Serial Number is found on the data plate located on the back of the unit.

MODEL: _____

SERIAL NUMBER: _____

DIRECTIONS FOR STORAGE AND HANDLING OF THE EQUIPMENT

STORAGE OF THE EQUIPMENT

If the equipment will be kept in storage, it is suggested to keep it in its original packing.

In case you need your equipment to be inactive for a long period of time after being used, verify that it has been unplugged. After cleaning it thoroughly with a damp cloth, lukewarm water and neutral soap and carefully drying it, cover it with a polyethylene film or similar waterproof material.

UNCRATING

The following procedure is recommended for uncrating the unit:

Remove the outer package by carefully cutting the banding and removing the cardboard box.

Inspect for concealed damage. Immediately file a claim with the freight carrier if there is damage.



Move your unit as close to the final location as possible before removing the wooden skid.

MOVING THE EQUIPMENT

The unit is shipped with casters to facilitate moving the unit into position.

Disconnect the power cord plug from the wall outlet. Remove product, then defrost, and clean the freezer. Secure all loose items such as baskets and fix the lids by taping them securely in place to prevent damage. In the moving vehicle, secure the freezer in an upright position and cover it to protect the outside of the cabinet.

PLACING AND INSTALLING THE EQUIPMENT

THIS UNIT CANNOT BE INSTALLED IN ENVIRONMENTS WITH EXPLOSIVE GASES. THE EQUIPMENT IS DESIGNED ONLY FOR INDOOR OPERATION.

The unit must be located in an indoor environment.

For the correct performance of the refrigerating system, it is very important to *leave at least 10 cm (4") of free space both at the sides and back* to allow proper air circulation. Do not block the grills on the side or back of the cabinet.

ENERGY SAVINGS IDEAS

The location of the cooler must be *kept away from sources of heat and humidity* including direct sunlight, toasters, ovens, coffee warmers, other appliances condenser air discharge, infrared heaters, or other heat generating appliances.

Overloading the freezer forces the compressor to run longer. Do not exceed the load limit according to labels fixed on the inner cabinet (which corresponds to the baskets height).

Product to be loaded should be at -4° F (-20° C) since the equipment is intended for maintaining a cool product at 0° F (-18° C) at load level rather than freezing a warm product

Keep the lids closed to avoid warm air and moisture getting into the freezer.



ELECTRICAL REQUIREMENTS

The power cord of this appliance is equipped with a 3-prong (grounding) plug which mates with a standard 3-prong (grounding) wall outlet to minimize the possibility of electric shock hazard from this appliance.

The use of extension cords is not permitted and will void the warranty.

Before connecting your equipment, check that the electrical data on the data plate match your electrical output. If voltage varies by 10 percent or more, freezer performance may be affected. Operating the freezer with insufficient power can damage the compressor. Such damage is not covered under the warranty. If you suspect voltage is high or low, consult your power company for testing.

To prevent the freezer from being turned off accidentally, do not plug unit into an outlet controlled by a wall switch or pull cord.

Do not pinch, knot, or bend the power cord in any manner.

IMPORTANT NOTICE: PLUG THE EQUIPMENT INDEPENDENTLY TO A LOAD CENTER WITH AN APPROPRIATE CIRCUIT BREAKER ACCORDING TO THE NAMEPLATE AMPS.

PRODUCT LOADING

The CHP series of units are not intended to be a pull down freezer and as such the product must be loaded at their intended merchandising temperature.

Before loading products, allow the equipment to operate empty for at least four hours.

BASKET SPECIFICATIONS

The baskets have been designed to withstand the rigors of normal use. Avoid product overloading to prevent deforming the baskets.

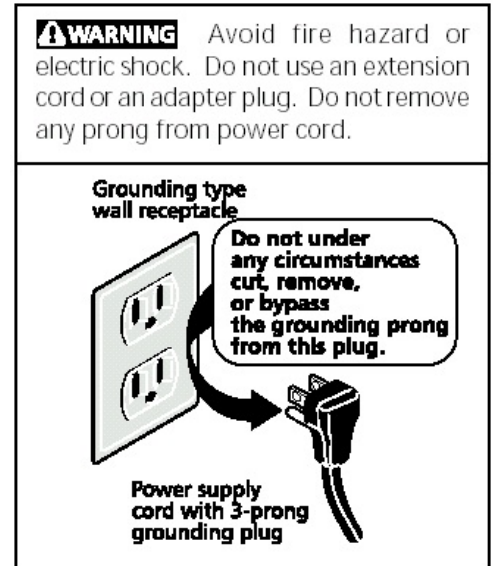

UNIT OPERATION

SETTING THE TEMPERATURE CONTROL

To access the temperature control, the right side grill should be removed using a Phillips screw driver.

The temperature control is factory pre-set to provide satisfactory product storage products. However, the temperature control is adjustable to provide a range of temperatures for your personal satisfaction. If a colder temperature is desired, turn the control clockwise. Allow several hours for temperature to stabilize between adjustments.

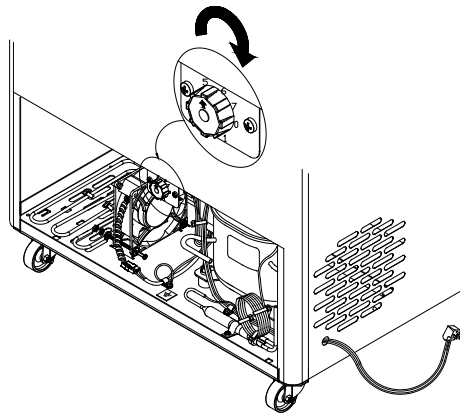

POWER FAILURE/FREEZER FAILURE

Note: Do not open the freezer door unnecessarily if power to the freezer is off for several hours

If a power failure occurs, frozen foods will stay frozen for at least 2 hours if the freezer is kept closed. If the power failure continues, pack seven or eight pounds of dry ice into the freezer every 24 hours. Cover the product with a cardboard sheet or one inch polyurethane sheet and close the lids. Always wear gloves and use caution when handling dry ice.

If the freezer has stopped operating, see **"Freezer does not run"** in the Service Checklist Section of this manual. **If you cannot solve the problem, call an authorized service immediately. Do not allow inexperienced people to repair or modify the electrical wiring and/or refrigeration components.**



SERVICE CHECKLIST

Before calling for service, review this list. It may save you both time and expense. This list includes common occurrences that are not the result of detective workmanship or materials in this appliance.

OCCURRENCE

SOLUTION

Freezer does not run	<p>Check to ensure that freezer is not plugged into a circuit that has ground fault interrupt. If you are unsure about the outlet, have it checked by a certified technician.</p> <p>Temperature control is in the OFF position. See Setting the Temperature Control Section.</p> <p>Freezer may not be plugged in, or plug may be loose. Be sure plug is tightly pushed into electrical outlet.</p> <p>House fuse has blown, or circuit breaker has tripped. Check/reset circuit breaker, or replace fuse with 15 amp. Time delay fuse</p> <p>Power outage. Check house lights. Call local electric company.</p>
Freezer runs too much or too long	<p>Room or outside weather is hot. It is normal for the freezer to work harder under these conditions.</p> <p>Freezer had recently been disconnected for a period of time. Freezer requires 4 hours to cool down completely.</p> <p>Large amounts of warm or hot product have been stored recently. Warm product will cause the freezer to run more until the desired temperature is reached.</p> <p>Door is kept open too long or too frequently. Warm air enters the freezer every time the door is opened. Open the door less often.</p> <p>Freezer door may be slightly open.</p> <p>Temperature control is set too cold. Turn the control knob to a warmer setting. Allow several hours for the temperature to stabilize.</p>
Temperatures inside the freezer are too cold	<p>Temperature control is set too cold. Turn the control to a warmer setting. Allow several hours for the temperature to stabilize.</p>
Temperatures inside the freezer are too warm	<p>Temperature control set too warm. Turn the control to a colder setting. Allow several hours for the temperature to stabilize.</p> <p>Door is kept open too long or is opened too frequently. Warm air enters the freezer every time the door is opened. Open the door less often</p> <p>Door may be open slightly.</p> <p>Freezer has recently been disconnected for a period of time. Freezer requires 4 hours to cool down completely.</p>
Temperature of external freezer surface is warm	<p>The exterior freezer walls can be as much as 30° F warmer than room temperature. This is normal while the compressor works to transfer heat from inside the freezer cabinet.</p>
Sound and noise	<p>The fan motor in the compressor compartment is damaged or has a loose connection</p>
Louder sound level whenever freezer is on	<p>Modern freezers have increased storage capacity and more even temperatures. They require a high efficiency compressor. When the surrounding noise level is low, you might hear the compressor running while it cools the interior.</p>
Louder sound levels when compressor comes on	<p>Freezer operates at higher pressures during the start of the ON cycle. This is normal. Sound will level off or disappear as freezer continues to run.</p>
Popping or cracking sound when compressor comes on	<p>Metal parts undergo expansion and contraction, as in hot water pipes. This is normal. Sound will level or disappear as freezer continues to run.</p>
Bubbling or gurgling sound, like water boiling	<p>Refrigerant (used to cool freezers) is circulating throughout the system. This is normal.</p>
Vibrating or ratting noise	<p>Freezer is not level. It rocks on the floor when it is moved slightly. Level the unit.</p> <p>Floor is uneven or weak. Freezer rocks on the floor when it is moved slightly. Be sure floor can adequately support freezer.</p> <p>Level the freezer by putting wood or metal shims under art of the freezer.</p>
Moisture forms on inside freezer walls	<p>Weather is hot and humid, which increases internal rate of frost build-up. This is normal.</p> <p>Door is slightly open.</p> <p>Door is kept open too long, or is opened too frequently.</p> <p>Door is slightly open, causing the cold air from inside the freezer to meet warm moist air from outside.</p>
Odor in freezer	<p>Interior needs to be cleaned. Clean interior with sponge, warm water, and baking soda.</p> <p>Product with strong odors are in the freezer. Cover the product tightly.</p>



PRESCRIPTIONS, PROHIBITIONS AND OTHER USES FOR THE EQUIPMENT

The equipment has been exclusively designed to maintain the proper temperature of packaged food products. Because the unit is not designed to cool the product down quickly, the product must be loaded at its appropriate temperature.

Displaying pharmaceutical products in this unit is prohibited.

CAUTION

- Do not remove grilles or panels that require using tools to be accessed
- Do not keep the unit running unloaded. UNPLUG IT when you are not planning to use it.

Using any electrical or electronic equipment entails the compliance with some fundamental rules.

- Do not touch the unit with wet hands or feet.
- Do not install the equipment outdoors.
- Do not remove or ignore safety devices.
- Do not leave objects on top of the unit.
- Do not climb on top of the unit.
- Never use direct or indirect water jets on the unit.
- Do not allow the electronic control to be adjusted by customers or unqualified personnel.
- Under no circumstance should you block the side or back grille of the unit.

THE MANUFACTURER DOES NOT ASSUME ANY RESPONSIBILITY ARISING FROM DAMAGES CAUSED BY IMPROPER, INCORRECT OR ERRONEOUS USE.

It is important to instruct the user on the operation of the equipment according to this instruction manual, and to make sure that said manual is within reach of any operator that might use the unit.



MAINTENANCE GUIDELINES

Regularly and carefully cleaning and defrosting the equipment prevents deterioration and product alteration.

REMOVAL OF FROST

It is recommended to remove the frost accumulated before reloading the freezer or anytime when one quarter inch of frost has accumulated.

The unit will have to be manually defrosted. The manual defrost frequency will depend on the units usage, environment, and the amount of frost accumulated.

1. Make sure the drain plug is removed and the unit is moved close to a floor drain.
2. Unplug the unit until all the frost is gone.
3. When the ice has melted wipe up any water left on the freezer floor.
4. Be sure to replace the drain plug before moving the freezer back into position.
5. Allow the freezer to refrigerate and cycle before placing the wire baskets and product back into the freezer

To defrost while keeping the freezer plugged in place a clean dry soft cloth over the product to catch the frost that will be removed. Remove the frost using a plastic scrapper trying to eliminate as much frost as possible.

CLEANING THE UNIT

Wash any removable parts, the freezer interior, and exterior with mild detergent and warm water. Wipe dry. **DO NOT USE HARSH CLEANERS ON THESE SURFACES.** Do not use razor blades or other sharp instruments, which can scratch the appliance surface.

CLEANING THE INSIDE

WARNING!

DAMP OBJECTS STICK TO COLD METAL SURFACES. DO NOT TOUCH THE INTERIOR METAL SURFACES WITH WET OR DAMP HANDS.

After defrosting, wash the inside surfaces of the freezer with a solution of two tablespoons of baking soda in one quarter of a gallon (1.1 liters) warm water. Rinse and dry. Wring excess water out of the sponge or cloth when cleaning in the area of the controls, or any electrical parts.

Wash the removable parts and door basket with the baking soda solution, or mild detergent and warm water. Rinse and dry. **Never** use metallic scouring pads, brushes, abrasive cleaners, or alkaline solutions on any surface. Do not wash removable parts in a dishwasher. **Do not shower water with a hose nor use ammonia based cleaners.**



WARNING THE LOWER SIDE OF THE GLASS LIDS IS PROVIDED WITH A SPECIAL FILM. DO NOT USE RAZOR BLADES OR OTHER SHARP INSTRUMENTS WHICH CAN SCRATCH THIS SURFACE AND DAMAGE THE FILM.

CLEANING THE OUTSIDE

Wash the cabinet with warm water and mild liquid detergent. Rinse well and wipe dry with a clean soft cloth. **Do not shower water with a hose nor use ammonia based cleaners.**

Clean every week with only a damp piece of cloth and neutral soap each external and internal surface, and dry them with a clean soft cloth.

Never use flammable or abrasive products. The unit must never be **cleaned with water jets.**

IMPORTANT: During maintenance and cleaning operations, make sure that good visibility conditions exist in the working area, using other light sources in case it is needed. Be very careful when working with moving and/or high-temperature parts.

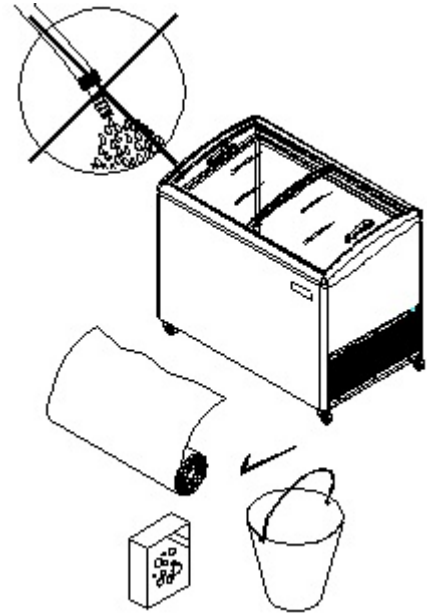

LID REMOVAL

If lids must be removed:

- 1 - Stand in front of the freezer (Fig.1)
- 2 - Assure that the lower lid is totally closed to the left side of the freezer (Fig.2)
- 3 - To remove the top lid, run it open to its maximum, handling it by both sides push it to the back (Fig.3). This allows the lid to get out from the front rail where it runs, then remove it pulling the lid out from the rear rail (Fig.4). Handle the lid carefully and place it in a straight safety place (see figure 5)
- 4 - Repeat step number 3 for removing the lower lid.
- 5 - To install the lids again, reverse the previous steps starting with the lower lid.

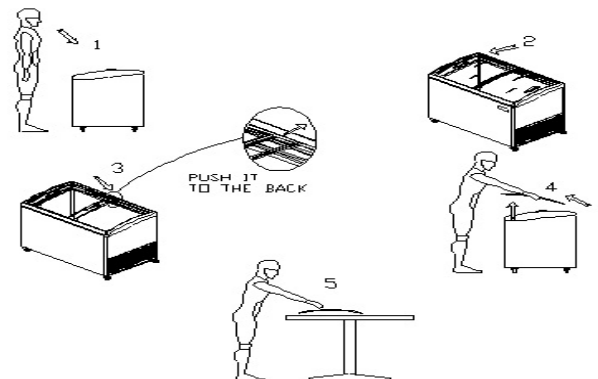

Standard Warranty

3 YEAR WARRANTY

(Applies to NB series, Dipping Cabinets, and NCF Series)

Warranty Claims

All claims for parts or labor must be made directly through Ojeda USA Inc.

All claims should include: model number of the unit, the serial number of the cabinet, proof of purchase, date of installation, and all pertinent information supporting the alleged defect.

In the case of compressor replacement under warranty, either compressor or compressor tag must be returned to Ojeda USA along with above listed information.

Failure to comply with warranty policies will result in voiding claims.

Two Year Parts & Labor Warranty

Ojeda USA Inc. warrants all new refrigerated components, the cabinet and all parts, to be free from defects in materials or workmanship, under normal and proper use and maintenance service as specified by Ojeda USA and upon proper installation. *Ojeda USA's obligation under this warranty is limited to a period of three (3) years from the date of the original installation or 39 months after shipment date from Ojeda USA Inc., whichever occurs first.*

Any part, covered under this warranty, that are by Ojeda USA Inc. to have been defective within three (3) years of original installation or thirty nine (39) months after shipment date from manufacturer, whichever occurs first, is limited to the repair or replacement, including labor charges of defective parts or assemblies. The labor warranty shall include standard straight time labor charges only and reasonable travel time, as determined by Ojeda USA Inc.

Additional Two Year Compressor Warranty

In addition to the three (3) year warranty stated above, Ojeda USA Inc. warrants its hermetically sealed compressor to be free from defects in both material and workmanship under normal and proper use and maintenance service for a period of two (2) additional years from the date of the original installation, but not to exceed five (5) years and three (3) months after shipment from the manufacturer. Compressor determined by Ojeda USA Inc. to have been defective within this extended period will, at Ojeda USA Inc. discretion, be either repaired or replaced with a compressor or compressor parts of similar design and capacity.

The two (2) year extended compressor warranty applies only to hermetically sealed parts of the compressor and does not apply to any other parts or components, including, but not limited to, cabinet, paint finish, temperature control, refrigerant, metering device, driers, motor starting equipment, fan assembly or and other electrical components, etcetera.

134a Compressor Warranty

The five-year compressor warranty detailed above will be void if the following procedure is not carefully adhered to:

1. This system contains R134a refrigerant and polyol ester lubricant. The polyol ester lubricant has rapid moisture absorbing qualities. If long exposure to the ambient conditions occurs, the lubricant must be removed and replaced with new lubricant. For oil amounts and specifications please call Ojeda USA Inc. technical service department at (888)532-2816.
2. Drier replacement is very important and must be changed when a system is opened for servicing. A drier using XH7 desiccant or an exact replacement solid core drier must be used. The new drier must also be the same capacity as the drier being replaced.
3. Micron level vacuums must be achieved to insure low moisture levels in the system. 500 microns or lower must be obtained.
4. When compressor is grounded, suction drier and 620 drier or better must be replaced.
5. Compressor must be obtained through Ojeda USA Inc., unless otherwise specified in writing, through Ojeda USA Inc. warranty department.

What is not covered by this warranty..

Ojeda USA Inc.'s sole obligation under this warranty is limited to either repair or replacement of parts, subject to additional limitations below. This warranty neither assumes nor authorizes any person to assume obligations other than those expressly covered by this warranty.

No consequential damages. Ojeda USA Inc. is not responsible for economic loss; profit loss; or special, indirect, or consequential damages, including without limitation, losses or damages arising from food or product spoilage claims whether or not on account of refrigeration failure. Warranty is not transferable. This warranty is not assignable and applies only in favor of the original purchaser/user to whom delivered. Any such assignment or transfer shall void the warranties herein made and shall void all warranties, express or implied, including any warranty of merchantability or fitness for a particular purpose.

Improper usage: Ojeda USA Inc. assumes no liability for parts or labor coverage for component failure or other damages resulting from improper usage or installation or failure to clean and/or maintain product as set forth in the warranty packet provided with the unit.

Residential applications: Ojeda USA Inc. assumes no liability for parts or labor coverage for component failure or other damages resulting from installation in non-commercial or residential applications. Ojeda is not responsible for the repair or replacement of any parts that Ojeda USA Inc. determines have been subject to ; alteration, neglect, abuse, misuse, accident, damage during transit or installation, fire, flood, acts of God. Ojeda USA Inc. is not responsible for the repair or replacement of failed or damaged components resulting from electrical power failure, the use of extension cords, low voltage, or voltage drops to the unit. No implied warranty of merchantability or fitness for a particular purpose. There are no other warranties, expressed, implied or statutory, except the three (3) year parts & labor warranty and the additional two (2) year compressor warranty as described above. This warranty does not apply to any warranty claims made outside the United States or Canada.



TECHNICAL ASSISTANCE

If technical personnel assistance is required, you must immediately contact your distributor, specifying the kind of problem and clearly indicating the equipment model and serial number. If replacing parts is required, do it through your distributor.

WARNING: Always ask for original spare parts

AUTHORIZED DISTRIBUTOR:

COMMERCIAL NAME:

ADDRESS:

TELEPHONE:

E-MAIL:

