



Grand Rapids, Michigan, U.S.A. 49504-5298

**USER'S OPERATING AND INSTRUCTION MANUAL**

**MODEL 619-16A**  
**MODEL 619-20A**  
**MODEL 619-24RA**

DOUGH DIVIDERS



**INDEX**

<u>Section Description</u>	<u>Document No.</u>	<u>Page No.</u>
SAFETY INSTRUCTIONS -----	0619S20047 -----	1-1
DESCRIPTION/SPECIFICATIONS -----	0619S20058 -----	2-1
Description -----		2-1
Physical Specifications -----		2-1
Electrical Specifications -----		2-2
Electrical Wiring Diagrams -----		2-2
OPERATING INSTRUCTIONS -----	0619S20048 -----	3-1
Before You Start -----		3-1
Basic Operation -----		3-1
MAINTENANCE -----	0619C20049 -----	4-1
Cleaning -----		4-1
Lubrication -----		4-1
Hydraulic Oil Specification -----		4-2
Hydraulic Filter Replacement -----		4-2
Removing The Lid -----		4-2
Replacing A Plastic Floor -----		4-2
Changing The Blades -----		4-3
Replacing The Thrust Plate -----		4-3
Replacing The Hydraulic Cylinder -----		4-4
Removing The Motor -----		4-4
Changing The Pump Or Coupling -----		4-5
Replacing The Control Valve -----		4-5
Adjusting The Pressure Relief On The Control Valve -----		4-6
TROUBLESHOOTING -----	0619S20050 -----	5-1
The "End of Stroke Light" Does Not Come On -----		5-1
The Motor "Hums" But Will Not Start -----		5-1
The Motor Runs But "Stalls" During The Cylinder's Stroke -----		5-1
The Motor Has "Stalled" And Cannot Be Restarted -----		5-2
The Divider Is Not Cutting Properly -----		5-2
RECOMMENDED SPARE PARTS -----	0619S20051 -----	6-1
REPLACEMENT PARTS SECTION		
MAIN FRAME PARTS -----	0619S20052 -----	7-1
Drawing -----		7-1
Parts List -----		7-2

Continued

REV. 2-26-04



### INDEX (Continued)

#### REPLACEMENT PARTS SECTION (Continued)

<u>Section Description</u>	<u>Document No.</u>	<u>Page No.</u>
COVERS -----	0619S20053 -----	8-1
Drawing -----		8-1
Parts List -----		8-2
HYDRAULIC PARTS -----	0619S20054 -----	9-1
Drawing -----		9-1
Parts List -----		9-2
LID PARTS -----	0619S20055 -----	10-1
Drawing -----		10-1
Parts List -----		10-2
ELECTRICAL PARTS -----	0619S20056 -----	11-1
Drawing -----		11-1
Parts List -----		11-2
PUSHER PARTS -----	0619S20057 -----	12-1
Drawing -----		12-1
Parts List -----		12-2
WARRANTY -----	GEN 040225	
WARRANTY PROCEDURE -----	GEN 040226	
RETURNED PARTS POLICY -----	GEN 040227	

REV. 2-26-04



## SAFETY INSTRUCTIONS

### **WARNING**

**VARIOUS SAFETY DEVICES AND METHODS OF GUARDING HAVE BEEN PROVIDED ON THIS MACHINE. IT IS ESSENTIAL HOWEVER THAT THE MACHINE OPERATORS AND MAINTENANCE PERSONNEL OBSERVE THE FOLLOWING SAFETY PRECAUTIONS. IMPROPER INSTALLATION, MAINTENANCE, OR OPERATION OF THIS EQUIPMENT COULD CAUSE SERIOUS INJURY OR DEATH.**

1. Before attempting to operate your divider read this manual. Never allow an untrained person to operate this machine.
2. Make sure that the machine is only connected to a properly grounded electrical supply source of sufficient capacity for the load the divider will put on it. Always unplug the machine when it is not in use.
3. Always make sure the machine has been disconnected from the power supply before cleaning or servicing.
4. All guards must be in place before starting the machine.
5. Keep your hands away from the moving parts of the machine.
6. Use only proper replacement parts.
7. Do not wear loose fitting clothing. Shirt tails should be tucked in.
8. In addition to these general safety instructions, also follow the more specific safety instructions given for the different areas of the machine in the operating instructions.

### **WARNING**

**DO NOT USE FOR OTHER THAN ORIGINALLY INTENDED PURPOSE.**

**THIS PAGE WAS INTENTIONALLY  
LEFT BLANK.**



---

---

## DESCRIPTION/SPECIFICATION

### Description

The Oliver divider consists of a hopper which can be loaded with dough from a minimum of ten and one half pounds up to forty-five pounds. The lid and hopper are made of heavy cast aluminum. The moveable hydraulic floor of the hopper is made of a collection of food grade plastic plates which, when moved upward, will compress the dough until it completely fills the remaining area. At this point a group of stainless steel knives come between the plates cutting the dough into equal weight, easy to use pieces.

This machine is ideal for pizza and bakery operations and is mounted on four casters for easy movement about the work area. The divider can divide pieces as small as seven ounces, on a 24 part divider, to as large as forty five ounces, on the 16 part divider. See below for specific maximums.

The hydraulic pump is powered by a two horse power, totally enclosed motor. The system has a built-in four and one half gallon hydraulic oil tank making the machine totally self contained.

### Physical specifications

## OVERALL MACHINE DIMENSIONS

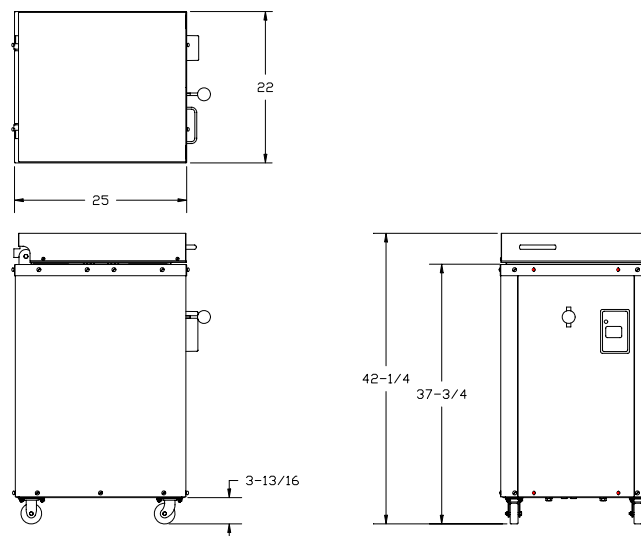



### Physical specifications (continued)

**Net Weight:**

Approximately 455 pounds.

**Shipping Weight:**

Approximately 500 pounds.

**Product Capacities:**

Fill Capacity (approximate) = 10-1/2 to 45 pounds

**Divided piece Size (approximate):**

16 part dividers = 10-1/2 to 45 ounces

20 part dividers = 8-1/2 to 36 ounces

24 part dividers = 7 to 30 ounces

### Electrical Specifications

2 Horse Power, 1 phase, 60 hertz, 230 Volts AC, 10 Amps.

2 Horse Power, 3 phase, 60 hertz, 208 Volts AC, 6.5 Amps.

2 Horse Power, 3 phase, 60 hertz, 230 Volts AC, 6.2 Amps.

2 Horse Power, 3 phase, 60 hertz, 460 Volts AC, 3.1 Amps.

Others consult factory

### Electrical Wiring Diagrams

1 ph, 60 hz, 230 VAC

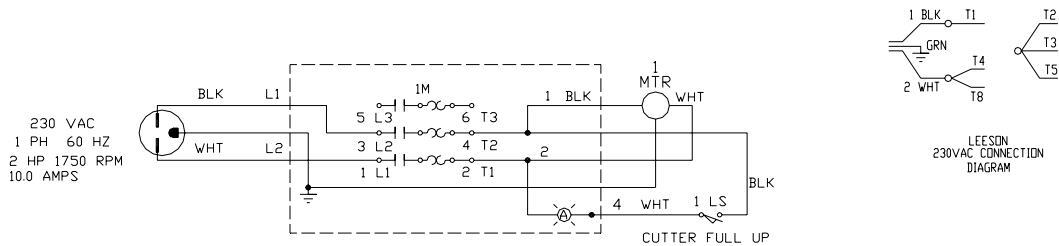

Continued



### Electrical Wiring Diagrams (Continued)

3 ph, 60 hz, 208/230 VAC

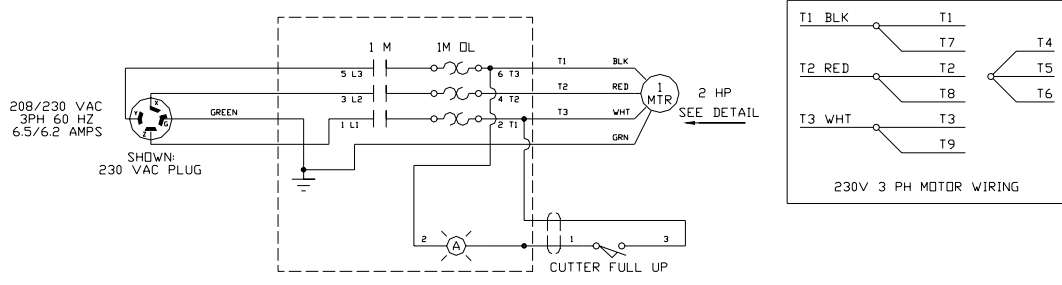

3 ph, 60 hz, 460 VAC

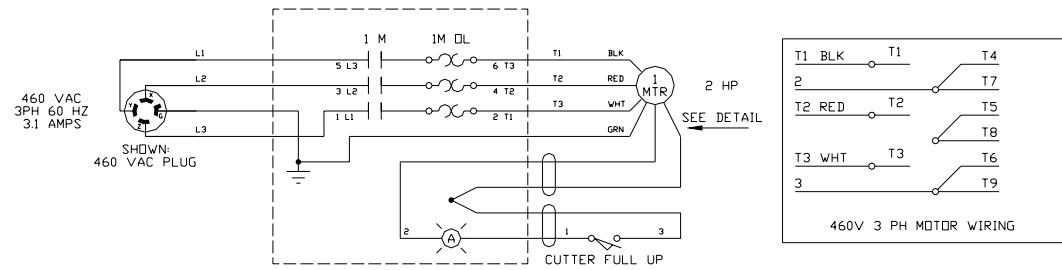





---

---

## OPERATING INSTRUCTIONS

### Before You Start

#### **CAUTION**

THE DIVIDER SHOULD **ONLY** BE PLUGGED INTO AN OUTLET WITH THE SAME VOLTAGE AS STATED ON THE NAMEPLATE

Before starting a new divider with **THREE PHASE** electrical power for the first time you should check to see if the motor is running in the correct direction. Remove the front cover by removing the four thumbscrews which secure it; you will also have to remove the handle from the directional control lever before removing the front cover. Once the cover has been removed you should be able to see the fan end of the motor on your divider, this fan **MUST** rotate in a clockwise direction.

#### **CAUTION**

EXTENDED RUNNING OF A DIVIDER WITH THE MOTOR ROTATING IN THE INCORRECT DIRECTION WILL SEVERELY DAMAGE THE HYDRAULIC PUMP OF YOUR DIVIDER.

If the motor is rotating in the incorrect direction turn the machine off, disconnect it from the power supply and have a qualified electrician reverse two of the three power wires in the plug at the end of the power cord. **DO NOT** move the ground, (green), wire.

#### **WARNING**

ALWAYS HAVE ELECTRICAL WORK DONE BY QUALIFIED ELECTRICIANS.

Recheck the divider making sure that it is now running in the correct direction, (clockwise looking at the fan end of the motor).

#### **CAUTION**

MOTOR ROTATION SHOULD BE CHECKED EVEN IF THE DIVIDER IS ONLY MOVED TO A DIFFERENT POWER OUTLET IN THE SAME ROOM

### Basic Operation

- Start by weighing out a piece of dough, which, when divided by the number of compartments available on your divider, will provide you with the desired end weight. For example: a thirty pound piece of dough after division on a twenty-four part divider will yield twenty-four, twenty ounce pieces, perfect for molding into one and a quarter pound loaves of bread.



---

---

### Basic Operation (Continued)

- Lower the floor of the hopper before attempting to open the lid of the divider.
- Open the lid and load the preweighed dough into the hopper. Spread the dough over the floor of the hopper making it approximately the same height, this is done to eliminate large air pockets and to insure equal division of the dough.
- Close and hold the lid down until dough compression has been started, (see the next step).
- With the machine running grasp the control valve handle and lift it to start the floor of the hopper up. Hold it in this position until the light on the starter switch box comes on, this means that the upward stroke has stopped and that division is complete. Let loose of the valve handle when you see the light come on.
- Press the control valve handle down slightly before opening the lid.
- The dough may be ejected by lifting the control valve handle to bring the plastic floors of the dough compartments level with the top of the hopper.
- We suggest that the cut pieces of dough be removed as soon as possible to prevent them from sticking together.
- Return the floor of the hopper to its lowest position by pushing down on the control valve handle. When complete this will allow filling of the machine for the next cycle.
- The above process may now be repeated.

<b><u>WARNING</u></b>
-----------------------

**NEVER** LEAVE DOUGH IN THE MACHINE; RISING DOUGH MAY  
CAUSE EXPLOSIVE PRESSURES TO DEVELOP.



---

---

## MAINTENANCE

### **WARNING**

**ALWAYS MAKE SURE THE MACHINE HAS BEEN DISCONNECTED FROM THE POWER SUPPLY BEFORE CLEANING OR SERVICING.**

#### **Cleaning**

**Remove-** all scraps from lower pan. Open side doors and brushing out all scraps. **Wash** all interior surfaces; Knives, pusher plates, hopper, lid surface with a damp rag and mild soap solution. The exterior and contact surfaces should be cleaned daily using common cleaners. The **knives** should be extended for easier cleaning. This can be done by placing the cleaning separator, furnished with the machine, **IN THE CENTER OF THE HOPPER** straddling the knives. Close the lid and bring the floor of the hopper up until the light on the manual starter is on, lower the floor slightly. **Open the lid and disconnect the divider from the power supply.** Clean the knives and plastic compartment floors of all dough build-up. **Rinse** all interior surfaces with a damp rag and clean water. **Sanitize** all interior surfaces with a damp rag and sanitizing solution. **Air Dry**, leave divider lid open and allow interior to air dry before using.

### **CAUTION**

IF NOT CLEANED A BUILD-UP OF DRIED DOUGH BETWEEN THE PLASTIC FLOORS AND THE KNIVES COULD DAMAGE THE DIVIDER.

In addition to the general cleaning discussed above, it is important that you check for and remove scraps of dried dough from between the blade holder and the bottom thrust plate. This can be done by first extending the knives as described above and then by removing the front and rear covers from the machine by removing the eight thumb screws and the control valve handle knob. This will allow access to the blade holder area, which can then be cleaned of all dried scraps of dough. When finished replace the covers and knob.

### **CAUTION**

FAILURE TO CLEAN DRIED DOUGH FROM THE BLADE HOLDER AND THRUST PLATE COULD RESULT IN SEVERE PUSHER DRIVE DAMAGE.

Occasionally, as required, you should also remove the build up of flour and dough particles in the base of the machine around the motor.



---

---

## Lubrication

The machine requires no lubrication but the oil level in the hydraulic system should be checked periodically. To check the oil level remove the rear cover by removing the four knobs which secure it to the divider, then remove the tank breather/cap and determine where the top of the oil is in relation to the top surface of the tank. Fill with oil to within approximately one inch of the top surface. If necessary add **HYDRAULIC OIL** to return it to the proper level, **DO NOT OVERFILL**. In addition to the above we advise replacing the hydraulic oil in the system approximately every three years.

## Hydraulic Oil Specification

The hydraulic oil used in your divider should be made of good quality base stocks compounded with the following additives: antiwear, antioxidation, antifoaming, and antirust. In addition it should be an "ISO" viscosity grade No. 32.

## Hydraulic Filter Replacement

At least once a year the throw-away filter on the hydraulic system should be replaced, more often when under heavy use. To replace the filter remove the front cover, unscrew the old filter and replace it with a new one. The filter is located on the return line near the front of the tank.

## Removing The Lid

- Remove the lid cover by removing the four screws, which secure it in position.
- Open the lid as far as it will go.
- Release the tension on the two large torsion springs by moving the long leg of the spring to the side and out from behind the bracket.

<b>WARNING</b>
----------------

USE CARE AS THE LID WILL DROP ONCE THE SPRING TENSION  
HAS BEEN REMOVED.

- Close the lid and remove the right hand snap ring from the lid hinge pin and push the pin to the left to remove it.
- Reassemble by reversing the above steps.



---

---

### Replacing A Plastic Floor

- Open the lid and raise the bottom of the hopper.
- Turn the machine off and disconnect it from the power supply.
- Remove the front and rear panels to gain access to the pusher components.
- Remove the nut securing the plastic floor and upright to the thrust plate.
- Using a block of wood or other soft material to protect the threads on the floor assembly, force it upwards until it is free from the thrust plate and then lift it from the blades.
- Once the assembly has been removed, it can be disassembled by removing the fasteners from the under side of the plastic floor which secure it to the upright.
- Replace each assembly by reversing the above steps.

### Changing The Blades

- To ease removal of the blade assembly the front, rear, and side panels should first be removed from the machine.
- Next remove all of the floor assemblies, see replacing plastic floors covered above.
- Remove the nuts securing the four blade holder braces, to the star plate.
- Lift the entire blade assembly, (blades, blade holder, and braces), out of the hopper.
- Once removed, a blade or blades can be replaced. Remember it is important before securing any blades that the blade holder and knife assembly be inverted on a surface plate or other known flat surface, verifying that all the blades are level and in line with each other. If no other flat surface is available the lid of the divider could be removed and used for this purpose.
- Once complete, re-insert the assembly in the hopper and reverse the above steps to re-assemble the machine.

### Replacing The Thrust Plate

- Should the thrust plate require replacement you should start by removing the blade assembly as described above.

(continued)



---

---

### Replacing The Thrust Plate (Continued)

- Remove the bolt securing the thrust plate to the cylinder rod. Once this bolt is removed the thrust plate can be lifted from the machine and replaced.
- When the machine is re-assembled the bolt securing the thrust plate to the cylinder rod should be installed using “Loctite” adhesive to prevent loosening during operation. The remaining components can be reinstalled by reversing the removal steps.

### Replacing The Hydraulic Cylinder

- Using the cleaning separator extend the knives about half of their travel. Turn the machine off and disconnect it from the power supply.
- To remove the hydraulic cylinder the front, rear, and side panels must be removed from the machine.
- Place blocks of wood between the thrust plate and the cylinder-mounting channel to secure it during cylinder removal.
- Remove one of the center plastic floor assemblies, (see above procedures). Once this has been done the bolt securing the thrust plate to the cylinder rod can be removed using a universal socket style wrench.
- Remove the four screws securing the star plate to the outer cylinder rod.
- Remove the bolts securing both the main starter switch bracket and the limit switch bracket to the hex support rods. **DO NOT** disconnect the wires.
- Remove one of the snap rings securing the yoke’s pivot pin. Remove the pin so that the linkage can be unhooked from the top of the machine.
- Remove the eight screws securing the cylinder to the cylinder-mounting channel.
- Remove the four bolts securing the cylinder-mounting channel to the lower hex support rods.
- The upper portion of the divider can now be removed and set to one side.
- Disconnect the high-pressure hose and lower tube assembly at the cylinder allowing removal of the cylinder for repair or replacement.

(continued)



### Replacing The Hydraulic Cylinder (Continued)

- When the machine is reassembled the bolt securing the thrust plate to the cylinder rod should be installed using “Loctite” thread locker #242 to prevent loosening during operation. All other components can be reinstalled by reversing the above steps.

### Removing The Motor

- Remove the front, rear and “Motor Side” panels.
- Remove the four screws securing the pump bracket to the front of the motor.
- Remove the four screws securing the motor to the shock mounts.
- Remove the terminal cover on the motor and disconnect the wiring, remember to note the wire locations to ease replacement of the motor.
- The motor should now be free and can be removed by sliding the motor out and lifting it free of the machine.
- Re-assemble by reversing the above steps.

### Changing The Pump Or Coupling

- Remove the rear cover and the “Motor Side” panel.
- Loosen the intake hose at the pump; make sure you have something available to catch the hydraulic oil leaking from the end of the hose when it is disconnected.
- Remove the high-pressure hose from the outlet side of the pump.
- Remove the four bolts from the feet of the motor which secure it to the shock mounts, this will allow the motor to be pivoted slightly to allow pump removal.
- Remove the bolts securing the pump to the bracket, pivot the motor and slide the pump with its half of the coupling out and free of the motor.
- Replace the pump by reversing the above procedures.



### Replacing The Control Valve

- Remove the front and side panels from the divider.
- Disconnect the four high-pressure hoses and remove the filter head assembly from the machine.
- Remove the lower pivot bolt from the lower end of the linkage connecting the valve and the control handle.
- Remove the three screws holding the valve to the valve mounting plate and remove the valve from the divider.
- Remove the remaining linkage parts from the old valve and re-install them on the new valve. The new valve can then be installed in the divider by reversing the above procedures.

### Adjusting The Pressure Relief On The Control Valve

- **IT IS NOT** necessary to adjust the pressure relief on replacement valves to allow proper operation of the divider. Note: Oliver's valves are normally preset at the factory and adjustment **IS NOT** necessary. Should it become necessary to change the pressure relief setting follow the two steps given below.
- Connect a pressure gauge at the quick disconnect provided on the high-pressure hose at the pump fitting. Note: a pressure gauge test kit can be purchased from Oliver Products Co. at additional cost.
- With the pump running use the calibrating screw in the bottom of the valve to set the pressure at 800 PSIG secure the calibrating screw in place with the locking nut once the proper pressure has been achieved.





---

---

## TROUBLE SHOOTING GUIDE

The “End of Stroke Light” does not come on.

### Possible Causes

- There may be a disconnected wire.
- The bulb may have burnt out.
- The limit switch is not adjusted properly.
- The limit switch is not operating and needs replacement.

The motor “Hums” but will not start.

### Possible Causes

- The motor is a dual voltage motor and may be wired for high voltage, but an attempt is being made to run it on low voltage.
- The electric supply to the motor is single phase instead of three phase.
- One of the leads of the three phase system has opened.

The motor runs, but, “Stalls” during the cylinder’s stroke.

### Possible Causes

- The incorrect overload relay was installed or the setting of that overload relay is incorrect.
- The setting of the pressure relief valve is too high.
- The motor is wired for high voltage but is connected to a low voltage supply.

The motor has “Stalled” and cannot be restarted.

Continued



---

---

## **TROUBLE SHOOTING (Continued)**

### Possible Causes

- The overload relay has tripped. Allow the relay about five minutes to cool and attempt to restart the divider.

The divider is not cutting properly.

### Possible Causes

- Dough scraps and flour have accumulated between the blade holder and the thrust plate. See “Cleaning” under maintenance.
- Check the oil level in the tank, refill if necessary see “Lubrication” under maintenance.
- Check to see if the calibrating screw on the control valve has become loose. If it has, check the procedure for setting the pressure, given under “Adjusting the Pressure Relief on the Control Valve” in the maintenance section.



---

---

## RECOMMENDED SPARE PARTS

### GENERAL

<u>PART NUMBER</u>	<u>PART DESCRIPTION</u>	<u>NO. REQ'D.</u>
7030-0023	RH Lid Spring	1
7030-0024	LH Lid Spring	1
5114-9556	Hydraulic Filter	1
0620-0047	Blade Holder Brace	4
0620-0012-1	Star Plate	1
5757-8081	Limit Switch	1
5709-9924	Starter Enclosure	1
5709-0191	Pilot Light	1
5709-3040	Motor Starter (3-60-460V)	1
5709-3041	Motor Starter (3-60-230V)	1
5709-3042	Motor Starter (3-60-208V)	1
5709-3043	Motor Starter (1-60-230V)	1

### SPARE PARTS FOR MODEL 619-16A ONLY

0620-0011-002	Blade Holder	1
0620-0048-002	Plastic Outside Plate	12
0620-0049-002	Plastic Inside Plate	4
0620-0052-003	Large Lower Blade	1
0620-0053-003	Large Upper Blade	1
0620-0054-003	Small Blade	12
0620-0055-003	Outside Blade	8

### SPARE PARTS FOR MODEL 619-20A ONLY

0620-0011	Blade Holder	1
0620-0048-003	Plastic Outside Plate	16
0620-0049-003	Plastic Inside Plate	4
0620-0052-001	Large Lower Blade	1
0620-0053-001	Large Upper Blade	1
0620-0054-001	Small Blade	16
0620-0055-001	Outside Blade	12

### SPARE PARTS FOR MODEL 619-24RA ONLY

0620-0011-001	Blade Holder	1
0620-0048-001	Plastic Outside Plate	20
0620-0049-001	Plastic Inside Plate	4
0620-0052-002	Large Lower Blade	1
0620-0053-002	Large Upper Blade	1
0620-0054-002	Small Blade	20
0620-0055-002	Outside Blade	16

Rev. 11/27/02



---

---

**OPTIONAL SPARE PARTS**

<b><u>PART NUMBER</u></b>	<b><u>PART DESCRIPTION</u></b>	<b><u>NO. REQ'D.</u></b>
5148-5624	Valve (Hydraulic)	1
5137-7004	Hydraulic Pump	1
5604-6958	Coupling	1
6303-6613	Motor 3 ph, 60 hz, 208/230/460 VAC	1
6303-6725	Motor 1 ph, 60 hz, 230VAC	1
0620-0050	Outer Plunger (619-16A, 619-20A)	4
0620-0050-001	Outer Plunger (619-24RA)	4
0620-0051	Inner Plunger (619-16A, 619-20A)	2
0620-0051-001	Inner Plunger (619-24RA)	2



### MAIN FRAME ASSEMBLY

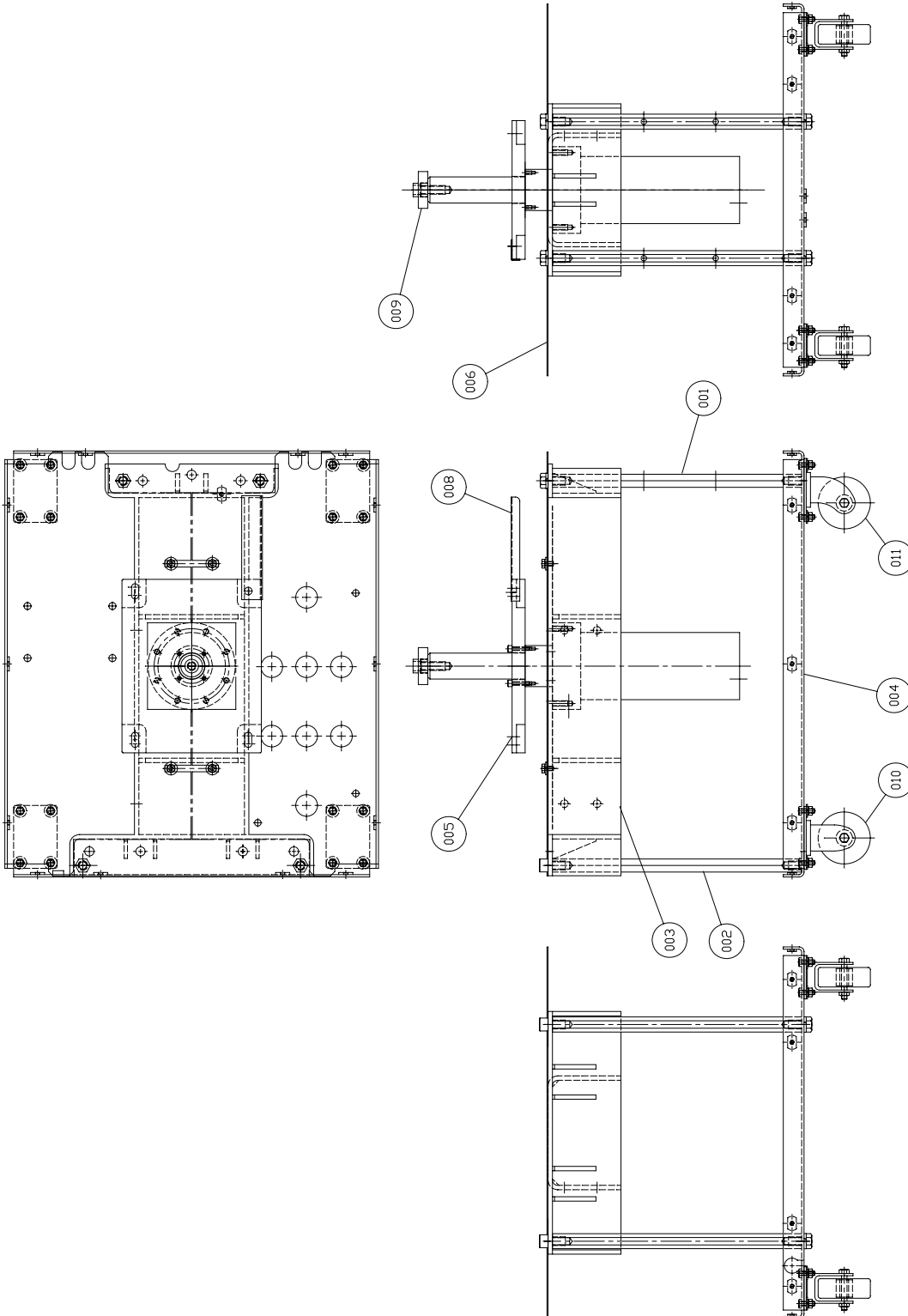



---

---

MAIN FRAME PARTS LIST

<u>ITEM NO</u>	<u>PART DESCRIPTION</u>	<u>PART NUMBER</u>
001	Brace-Lower W/Holes	0620-0005-001
002	Brace-Lower	0620-0006
003	Plate-Cylinder Support	0620-0007-001
004	Base	0620-0008
005	Plate-Star	0620-0012-1
006	Panel-Separation	0620-0032
008	Actuator-Limit Switch	0620-0044-1
009	Spacer-Cylinder Rod	0620-0045
010	Caster-Ridged	5902-2378
011	Caster-Swivel W/Brake	5902-2377

FOR SERVICE PARTS CALL OLIVER PRODUCTS @ 800-253-3893

Rev. 5-01-01



### COVERS ASSEMBLY

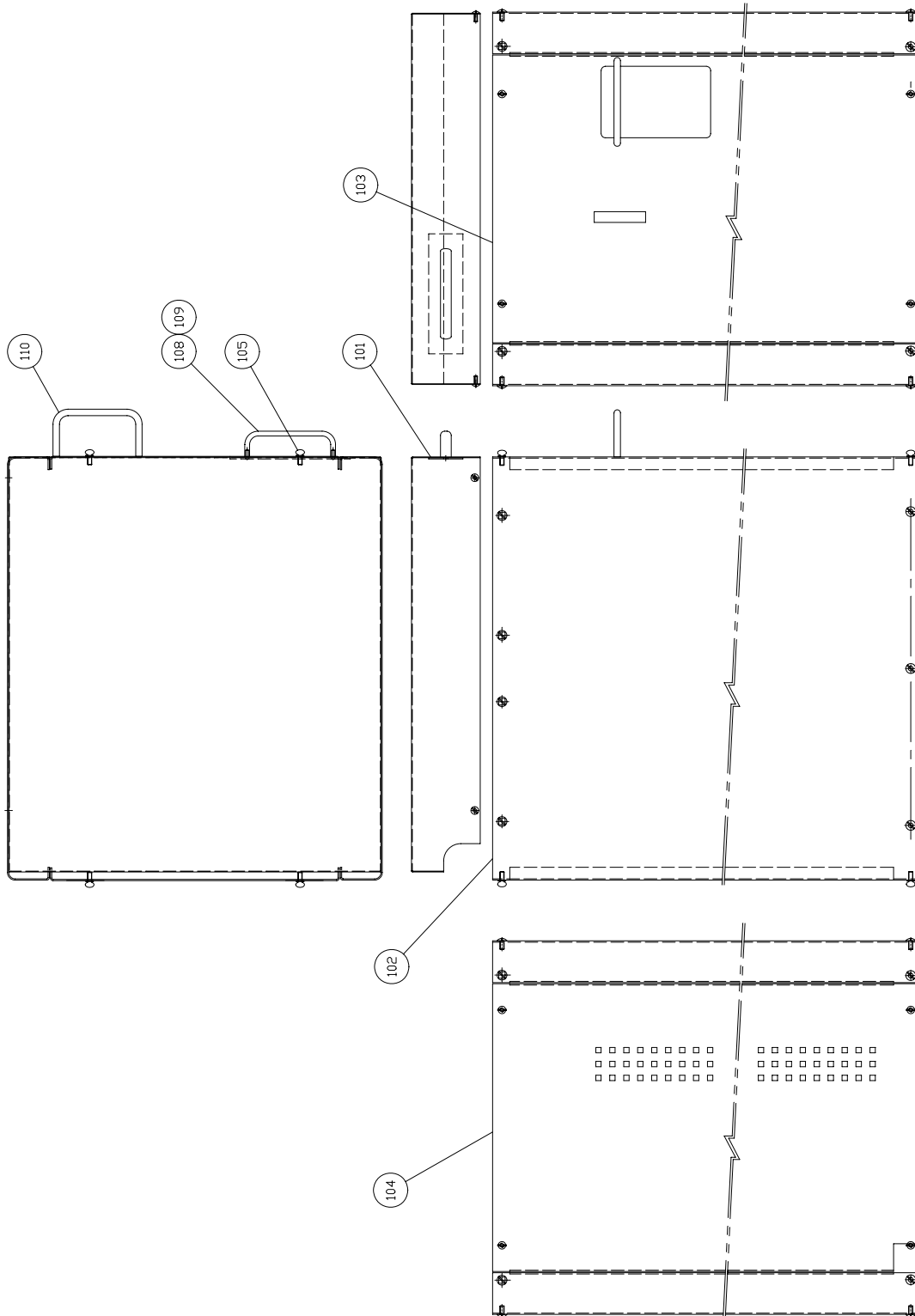



---

---

COVERS PARTS LIST

<u>ITEM NO</u>	<u>PART DESCRIPTION</u>	<u>PART NUMBER</u>
101	Guard-Top Cover (Painted) Guard-Top Cover (Stainless)	0620-0001-002 0620-0001-003
102	Cover-Side (Painted) Cover-Side (Stainless)	0620-0029 0620-0029-002
103	Cover-Front (Painted) Cover-Front (Stainless)	0620-0030 0620-0030-003
104	Cover-Rear (Painted) Cover-Rear (Stainless)	0620-0031 0620-0031-001
105	Screw-Thumb	5843-0536
108	Handle-Pull	5908-5101
109	Plate-Handle Backing	0619-0028
110	Guard-Switch	0620-0106

FOR SERVICE PARTS CALL OLIVER PRODUCTS @ 800-253-3893





### HYDRAULIC ASSEMBLY

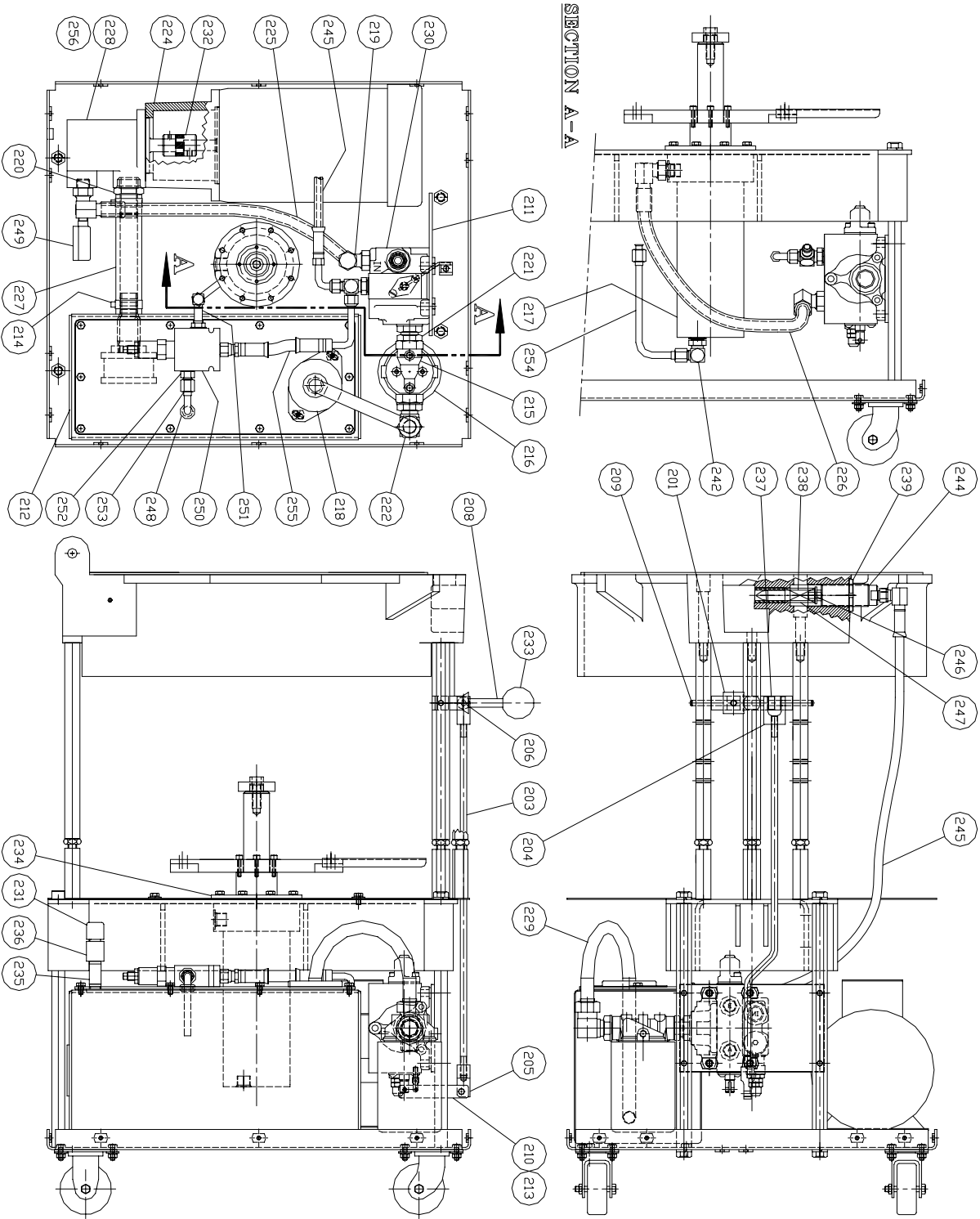

Rev. 12/21/04



---

---

HYDRAULIC PARTS LIST

<u>ITEM NO</u>	<u>PART DESCRIPTION</u>	<u>PART NUMBER</u>
201	Stirrup	0620-0015
203	Rod-Valve Actuating	0620-0019-002
204	Clevis-Rod	0620-0020
205	Rod-Eye	0620-0021
206	Pin-Long	0620-0022
208	Rod-Handle	0620-0024-002
209	Pin-Stirrup Pivot	0620-0025
210	Lever-Valve Actuating	0620-0026-001
211	Plate-Valve Mtg.	0620-0027-001
212	Tank-Oil	0620-0069-002
213	Spacer	0620-0086
214	Hose Clamp	5106-8087
215	Filter Head	5114-9554
216	Filter-Spin On	5114-9556
217	Cylinder-Custom Hydraulic	5108-7818
218	Flange-Tank	5115-0388
219	Fitting-Elbow	5115-2090
220	Fitting-Hose	5115-2079
221	Fitting-Adapter	5115-4031
222	Fitting-Adapter	5115-4032
224	Flange-Pump Mounting	5137-7375
225	Hose-Pump	5121-8235
226	Hose-Upper	5121-8174
227	Hose-Hydraulic	0619-0016
228	Pump-Vane	5137-7004
229	Tube-Return	5146-9010
230	Valve-4 Way W/Fittings	5148-5624
231	Breather-Tank	5149-0204
232	Coupling	5604-6958
233	Knob	5911-7001
234	Plate-Cylinder Alignment	0620-0120
235	Nipple-Black Pipe	6203-0407
236	Coupling-Black Pipe	5115-0332
237	Spacer	0619-0033
238	Pin-Locking	0619-0032-001
242	Fitting-Elbow	5115-2087
244	Cylinder-Latch	5108-7299
245	Hose-Latch Cylinder	5121-8091
246	Washer-Special	0619-0035
247	Spring	7014-3105
249	Gauge	5118-0506
250	Manifold	5128-5100
251	Fitting-90 Elbow	5115-2086
254	Tube-Sequence	5147-0103
255	Hose-Valve to Sequence	5121-8164
256	Spacer-Pump/Flange	0619-0044

FOR SERVICE PARTS CALL OLIVER PRODUCTS @ 800-253-3893

Rev. 10/25/06



### LID ASSEMBLY

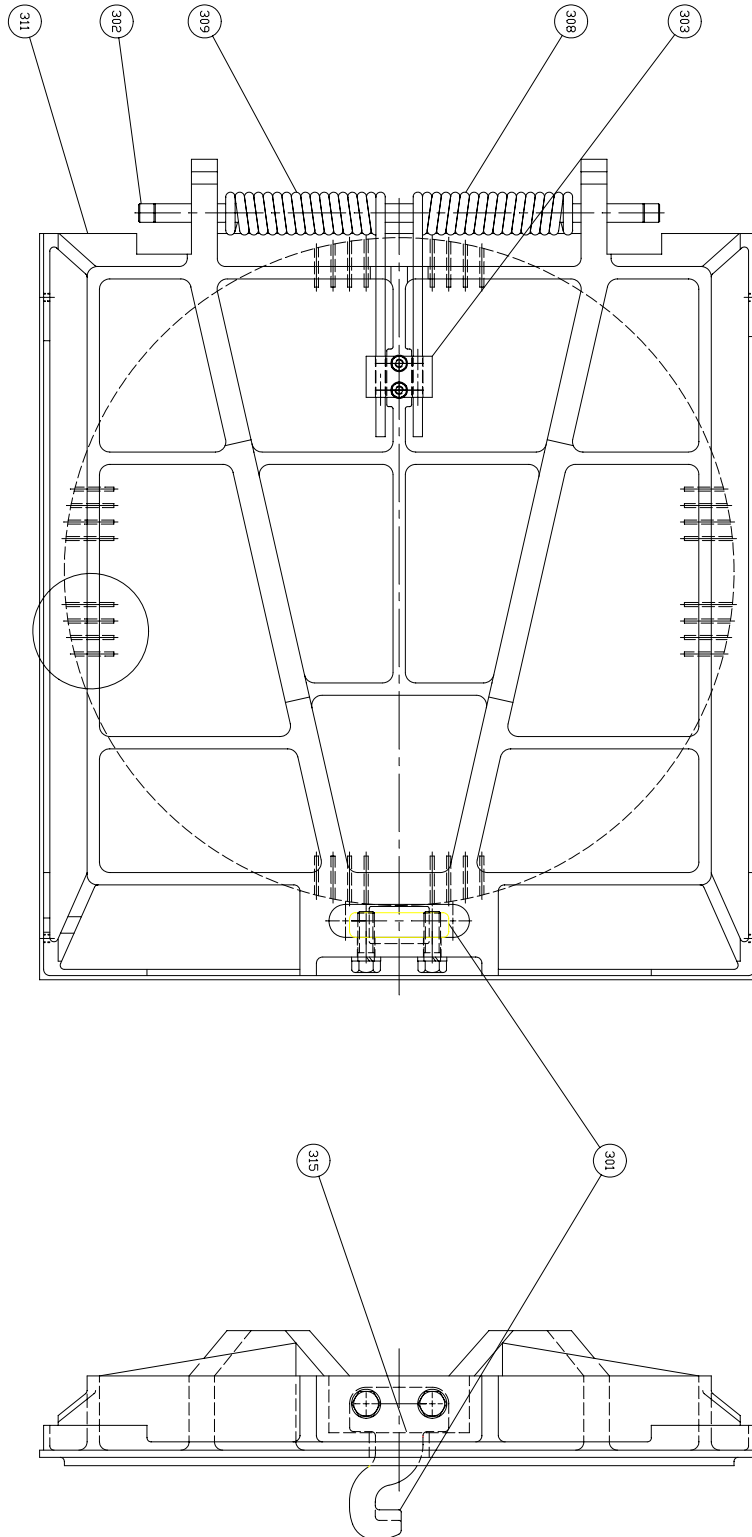



---

---

LID PARTS LIST

<u>ITEM NO</u>	<u>PART DESCRIPTION</u>	<u>PART NUMBER</u>
301	Hook-Lid	0619-0031
302	Pin-Hinge	0620-0033
303	Clamp-Spring	0620-0034
308	Spring-LH	7030-0024
309	Spring-RH	7030-0023
311	Lid-Round Auto-Latch	0619-0022-001
315	Shim-Hook (.005)	0619-0030-005
	Shim-Hook (.010)	0619-0030-01

FOR SERVICE PARTS CALL OLIVER PRODUCTS @ 800-253-3893

Revised 2/7/02



---

---

### ELECTRICAL ASSEMBLY

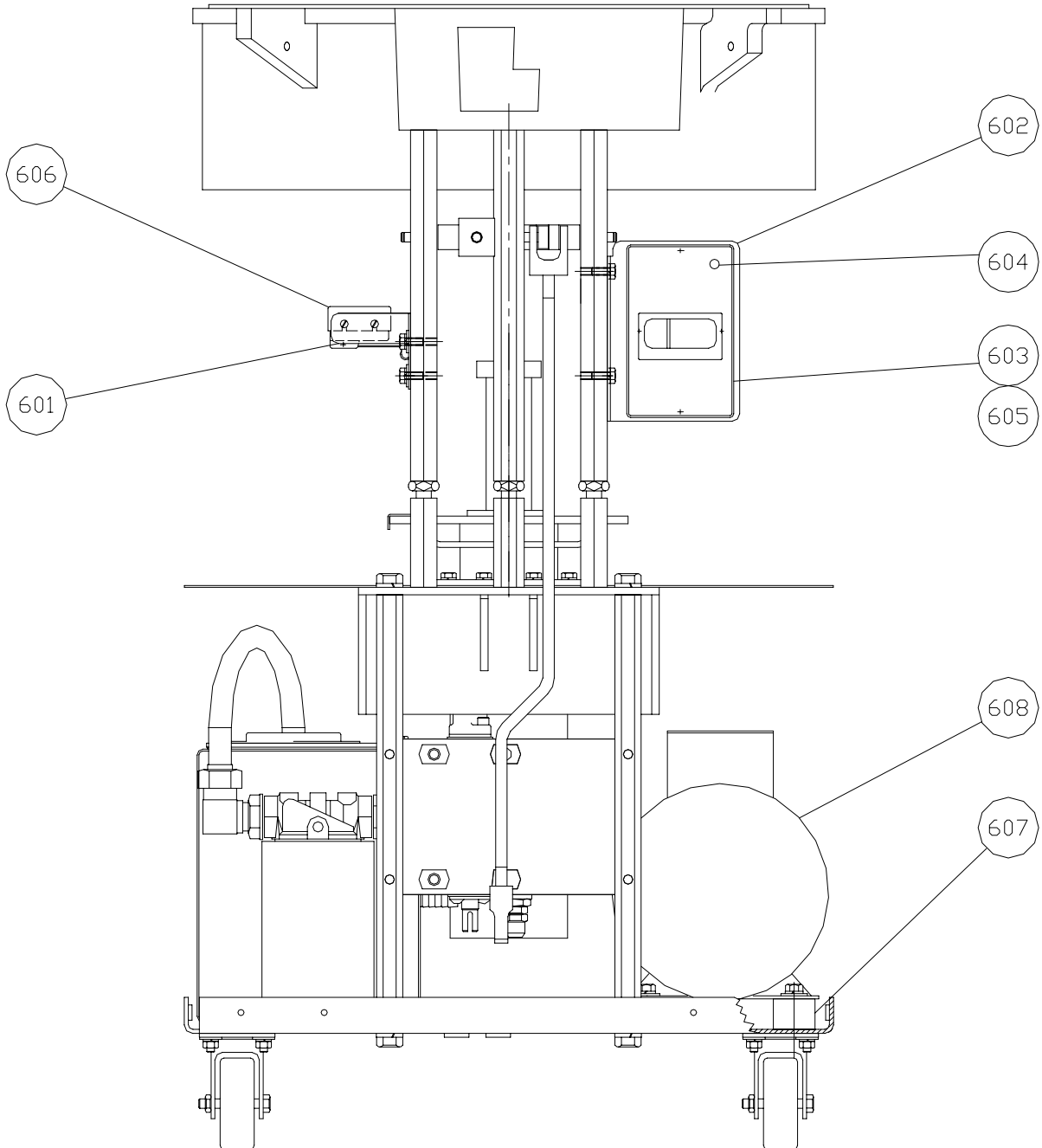

Rev. 11/27/02



---

---

ELECTRICAL PARTS LIST

<b>ITEM NO</b>	<b>PART DESCRIPTION</b>	<b>PART NUMBER</b>
601	Bracket-Limit Switch	0620-0041-001
602	Bracket-Starter	0620-0042-1
603	Enclosure	5709-9924
604	Light-Pilot	5709-0191
605*	Starter-Manual (10-15A) (1-60-230)	5709-3043
	Starter-Manual (6.3-10A) (3-60-208)	5709-3042
	Starter-Manual (4-6.3A) (3-60-230)	5709-3041
	Starter-Manual (2.5-4A) (3-60-460)	5709-3040
606	Switch-Limit	5757-8081
607	Shockmount	5918-6636
608*	Motor-2HP (1-60-230)	6303-6725
	Motor-2HP (3-60-208/203/460)	6303-6613

\* For Other Electrics Consult the Factory

FOR SERVICE PARTS CALL OLIVER PRODUCTS @ 800-253-3893

Rev. 11/27/02



**PUSHER ASSEMBLY**  
(16 Part Pusher Assembly Shown for Reference Only)

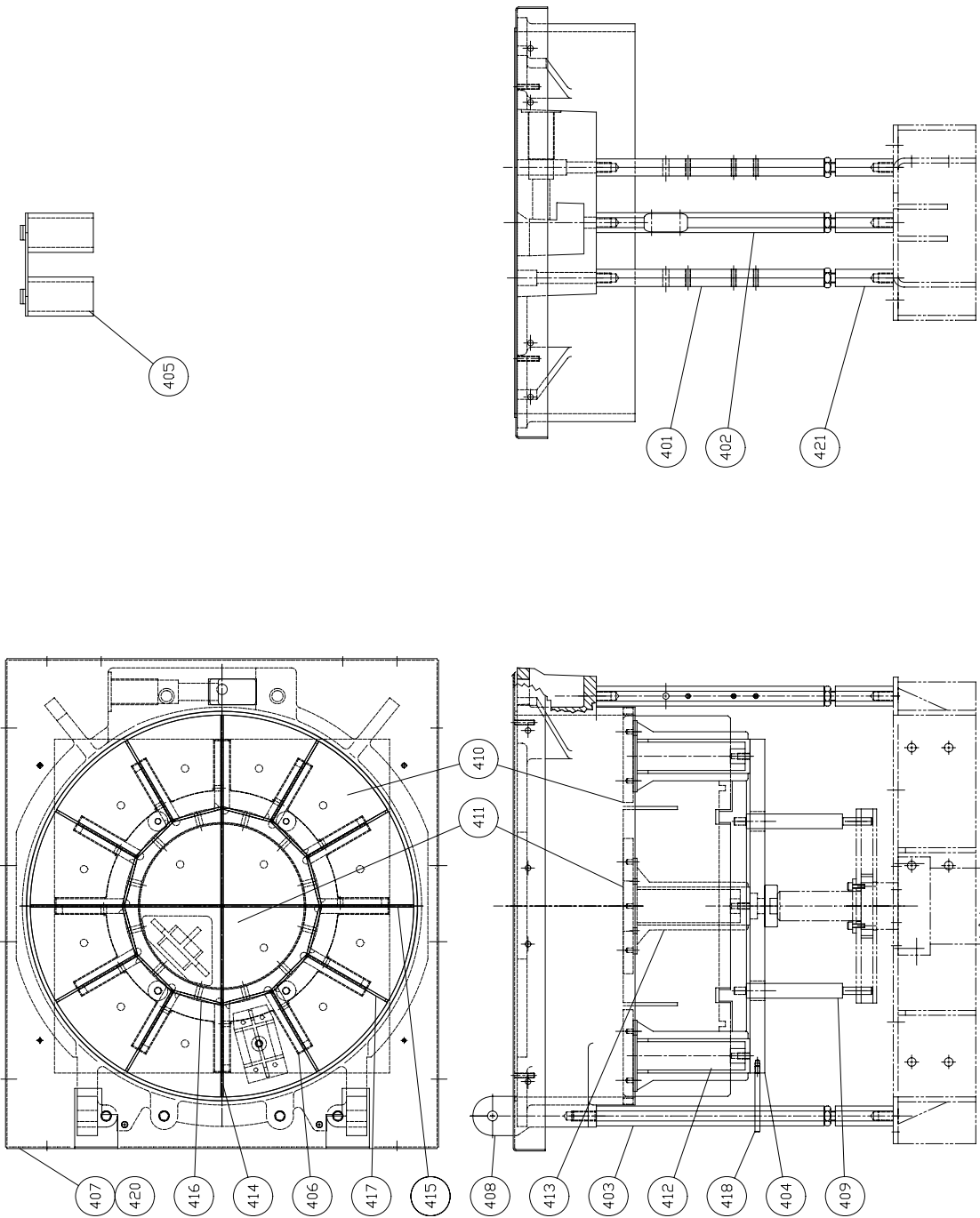



---

---

PUSHER PARTS LIST

<b>ITEM NO</b>	<b>PART DESCRIPTION</b>	<b>PART NUMBER</b>
401	Adj. Upper Brace W/Holes	0619-0023
402	Adj. Upper Milled Brace	0619-0024
403	Adj. Rear Upper Brace	0619-0025
404	Plate-Thrust (619-16A)	0620-0009-003
	Plate-Thrust (619-20A)	0620-0009
	Plate-Thrust (619-24RA)	0620-0009-002
405	Separator-Cleaning	5503-4301
406	Blade Holder (619-16A)	0620-0011-002
	Blade Holder (619-20A)	0620-0011
	Blade Holder (619-24RA)	0620-0011-001
407	Top Cover	0620-0013-001
408	Round Hopper	0619-0021-002
409	Brace-Blade Holder	0620-0047
410	Plate-Plastic Outer (619-16A)	0620-0048-002
	Plate-Plastic Outer (619-20A)	0620-0048-003
	Plate-Plastic Outer (619-24RA)	0620-0048-001
411	Plate-Plastic Inner (619-16A)	0620-0049-002
	Plate-Plastic Inner (619-20A)	0620-0049-003
	Plate-Plastic Inner (619-24RA)	0620-0049-001
412	Plunger-Outer Lifting (619-16A & -20A)	0620-0050
	Plunger-Outer Lifting (619-24RA)	0620-0050-001
413	Plunger-Inner Lifting (619-16A & -20A)	0620-0051
	Plunger-Inner Lifting (619-24RA)	0620-0051-001
414	Blade-Large Lower (619-16A)	0620-0052-003
	Blade-Large Lower (619-20A)	0620-0052-001
	Blade-Large Lower (619-24RA)	0620-0052-002
415	Blade-Large Upper (619-16A)	0620-0053-003
	Blade-Large Upper (619-20A)	0620-0053-001
	Blade-Large Upper (619-24RA)	0620-0053-002
416	Blade-Small Circular (619-16A)	0620-0054-003
	Blade-Small Circular (619-20A)	0620-0054-001
	Blade-Small Circular (619-24RA)	0620-0054-002
417	Blade-Outside (619-16A)	0620-0055-003
	Blade-Outside (619-20A)	0620-0055-001
	Blade-Outside (619-24RA)	0620-0055-002
418	Pin-Guide	0620-0056
420	Bracket-Top Cover Mounting	0620-0107
421	Adjustable Hex	0619-0026

FOR SERVICE PARTS CALL OLIVER PRODUCTS @ 800-253-3893

Rev. 8-20-01



**THIS PAGE WAS INTENTIONALLY  
LEFT BLANK.**



## WARRANTY

### PARTS

Oliver Packaging & Equipment Company (Oliver) warrants that if any part of the equipment (other than a part not manufactured by Oliver) proves to be defective (as defined below) within one year after shipment, and if Buyer returns the defective part to Oliver within one year, Freight Prepaid to Oliver's plant in Grand Rapids, MI, then Oliver, shall, at Oliver's option, either repair or replace the defective part, at Oliver's expense.

### LABOR

Oliver further warrants that equipment properly installed in accordance with our special instructions, which proves to be defective in material or workmanship under normal use within one (1) year from installation or one (1) year and three (3) months from actual shipment date, whichever date comes first, will be repaired by Oliver or an Oliver Authorized Service Dealer, in accordance with Oliver's published Service Schedule.

For purposes of this warranty, a defective part or defective equipment is a part or equipment which is found by Oliver to have been defective in materials workmanship, if the defect materially impairs the value of the equipment to Buyer. Oliver has no obligation as to parts or components not manufactured by Oliver, but Oliver assigns to Buyer any warranties made to Oliver by the manufacturer thereof.

This warranty **does not** apply to:

1. Damage caused by shipping or accident.
2. Damage resulting from improper installation or alteration.
3. Equipment misused, abused, altered, not maintained on a regular basis, operated carelessly, or used in abnormal conditions.
4. Equipment used in conjunction with products of other manufacturers unless such use is approved by Oliver Products in writing.
5. Periodic maintenance of equipment, including but not limited to lubrication, replacement of wear items, and other adjustments required due to installation, set up, or normal wear.
6. Losses or damage resulting from malfunction.

The foregoing warranty is in lieu of all other warranties expressed or implied AND OLIVER MAKES NO WARRANTY OF MERCHANTABILITY OR FITNESS FOR PURPOSE REGARDING THE EQUIPMENT COVERED BY THIS WARRANTY. Oliver neither assumes nor authorizes any person to assume for it any other obligations or liability in connection with said equipment. OLIVER SHALL NOT BE LIABLE FOR LOSS OF TIME, INCONVENIENCE, COMMERCIAL LOSS, INCIDENTAL OR CONSEQUENTIAL DAMAGES.

**THIS PAGE WAS INTENTIONALLY  
LEFT BLANK.**



Oliver Packaging & Equipment Company  
511 Sixth Street NW • Grand Rapids, MI 49504

(800) 253-3893  
[www.oliverquality.com](http://www.oliverquality.com)

## WARRANTY PROCEDURE

1. If a problem should occur, either the dealer or the end user must contact the Parts and Service Department and explain the problem.
2. The Parts and Service Manager will determine if the warranty will apply to this particular problem.
3. If the Parts and Service Manager approves, a Work Authorization Number will be generated, and the appropriate service agency will perform the service.
4. The service dealer will then complete an invoice and send it to the Parts and Service Department at Oliver Products Company.
5. The Parts and Service Manager of Oliver Packaging and Equipment Company will review the invoice and returned parts, if applicable, and approve for payment.

**THIS PAGE WAS INTENTIONALLY  
LEFT BLANK.**



Oliver Packaging & Equipment Company  
511 Sixth Street NW • Grand Rapids, MI 49504

(800) 253-3893  
[www.oliverquality.com](http://www.oliverquality.com)

## RETURNED PARTS POLICY

This policy applies to all parts returned to the factory whether for warranted credit, replacement, repair or re-stocking.

Oliver Packaging and Equipment Company requires that the customer obtain a Return Material Authorization (RMA) number before returning any part. This number should appear on the shipping label and inside the shipping carton as well. All parts are to be returned prepaid. Following this procedure will insure prompt handling of all returned parts.

To obtain an RMA number contact the Repair Parts Department toll free at (800) 253-3893.

Parts returned for re-stocking are subject to a **RE-STOCKING CHARGE**.

Thank you for your cooperation,

Repair Parts Manager  
Oliver Packaging and Equipment Company