

INSTALLATION and OPERATION INSTRUCTIONS

Roll Top Bottle Coolers

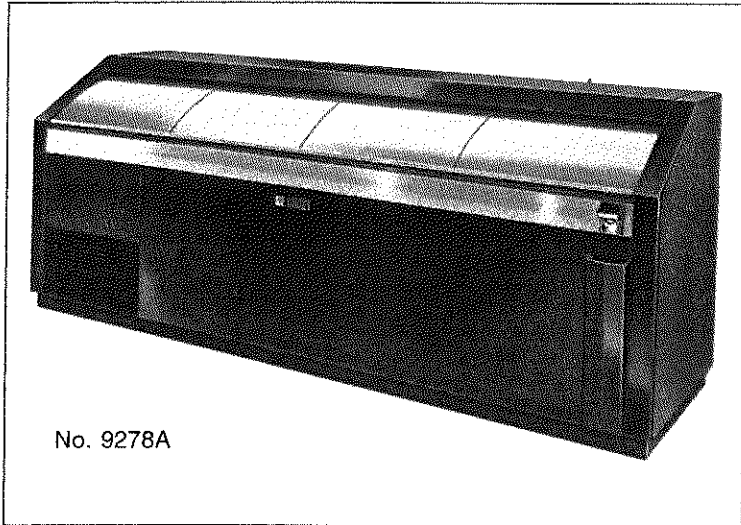

Model Nos.
 9276A Series
 9277A Series
 9278A Series

Table of Contents

Cabinet Specifications	2
Installing	
Adjusting Partitions	3
Placing and Leveling	3
Sealing to the Floor	3
Temperature Control	4
Removing Doors	4
Cleaning Cabinet	4
Replacement Parts	5
Cleaning Stainless Steel	6
Wiring Diagram	7

IMPORTANT WARRANTY INFORMATION

A Warranty card is enclosed that must be filled out and mailed to the Perlick Corporation in order to register the warranty. If the card is not returned to Perlick, the warranty period will begin from the date the equipment is shipped from the factory.

This manual has been prepared to assist you in the installation of your Bottle Cooler and to acquaint you with its operation and maintenance.

We dedicate considerable time to ensure that our products provide the highest level of customer satisfaction. If service is required, your dealer can provide you with a list of qualified service agents. For your own protection, never return merchandise for credit without our approval.

We thank you for selecting a Perlick product and assure you of our continuing interest in your satisfaction.



8300 West Good Hope Road
 Milwaukee, WI 53223
 Phone: 414-353-7060 Fax: 414-353-7069

SPECIFICATIONS

ROLL TOP BOTTLE COOLERS

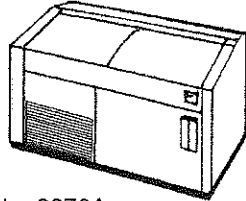

No. 9276A

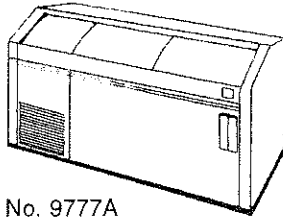

No. 9277A

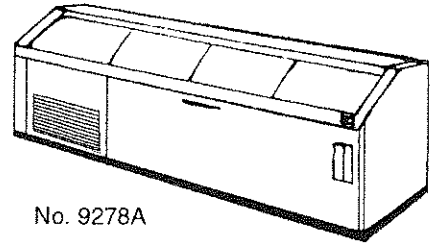

No. 9278A

MODEL NOS.		9276A	9277A	9278A
DIMENSIONS EXTERIOR	Length	54 ³ / ₈ " (1381mm)	78 ¹ / ₈ " (1984mm)	102 ³ / ₁₆ " (2596mm)
	Depth	29 ¹ / ₂ " (749mm)	29 ¹ / ₂ " (749mm)	29 ¹ / ₂ " (749mm)
	Height	39 ⁷ / ₈ " (1013mm)	39 ⁷ / ₈ " (1013mm)	39 ⁷ / ₈ " (1013mm)
CASE CAPACITY	12 oz. Export Bottles	17.5	19.16	20.33
	12 oz. Mod Bottles	32.0	34.16	37.0
	12 oz. Cans	46.0	49.0	53.5
NO. OF BINS		4	6	8
COMPRESSOR SIZE		1/4	1/3	1/2
AMPS		6.14	7.8	9.6
SHIPPING WEIGHT lbs. (kg.)		400 (181.5)	530 (240.5)	760 (345)
INTERIOR	All walls, baffles, 22 gauge zinc-clad cold-rolled steel. Bottom 20 gauge with turned edges and raised corners. Inner liner joints spot welded. Insulation self-supporting, semi-rigid, 3" fiberglass. Adjustable partitions, bin dividers, and bottom plates are heavy wire, zinc-plated and lacquered.			
EXTERIOR	Painted Models: Front, sides, top, bottom, and recessed base is 20 gauge cold-rolled steel, finished in black baked enamel with stainless steel protective front rail. Back 20 gauge cold-rolled steel. Stainless Steel Models: Front, sides, and top are 20 gauge, Type 304, No. 4 finish nickel-alloy stainless steel. Cold-rolled steel back. Black enamel recessed base and bottom.			
ELECTRICAL	115 V, 60 Hz., 1 ph. AC Can be modified for other voltages; contact Perlick Sales Offices. Furnished with a six foot, three-prong rubber cord.			
REFRIGERATION	Balanced refrigeration system. Jumbo-sized evaporator coil with permanently lubricated, oversized blowers. Adjustable temperature control. Frost free; self-defrosting. Compressor pulls out for "in-place" service.			
PLUMBING	No drain required. Removable condensate pan.			
INSULATION	Self-supporting, semi-rigid, 3" fiberglass.			
OPTIONAL ACCESSORIES	No. C8484-1 Main partition (21 ¹ / ₄ " x 21 ¹ / ₄ ") No. C8485-1 Center partition (21 ¹ / ₄ " x 17 ¹ / ₈ ") <i>(Use in front of evaporator housing)</i> No. C816037 Short partition (7 ¹³ / ₁₆ " x 21 ¹ / ₄ ") C15756* 2nd bottle opener & receiver <i>(Use over condensing unit housing)</i> C15756IN* 2nd bottle opener & receiver-installed No. C6757 Bin subdivider (20" x 11 ¹¹ / ₁₆ ") <i>(For inside bins only. End bins excluded).</i> *Add SS to part number for a stainless steel receiver.			

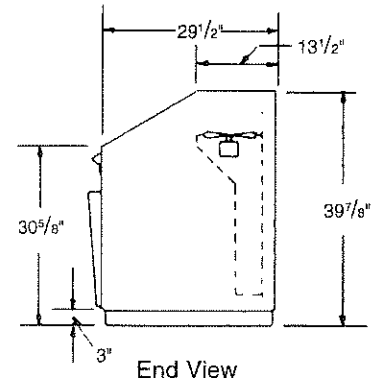
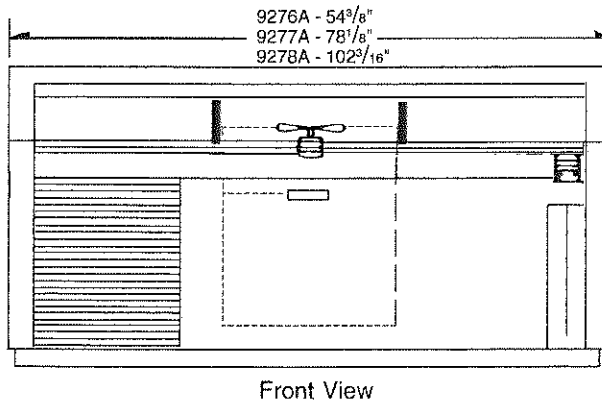

PREPARING the CABINET

ROLL TOP BOTTLE COOLERS

PLUMBING

No plumbing connections required. Condensate from the cooling coil is automatically evaporated through a condensate pan located in the condensing unit section.

ELECTRICAL

The cabinet must be connected to a separately fused power source (see Electrical Specification Plate) and grounded in accordance with National and Local Electrical Codes. **Caution:** Do not attempt to operate the equipment on any other power source than that listed on the Electrical Specification Plate.

ADJUSTABLE PARTITIONS

Perlick Bottle Coolers are provided with adjustable partitions which will accommodate various bottle sizes.

- Remove bottles from their cases before placing in cooler to ensure proper air flow.
- For maximum efficiency, bottles should be cored.

PLACING the CABINET

To assure maximum performance, fresh air must be allowed to circulate through the machinery compartment. It is important to allow at least two inches of clearance at the back or left end of the cabinet. Do not place anything on the top or in front of the cabinet that would obstruct air flow at these grilles.

Cabinet should either be leveled or pitched slightly toward the drain to allow any accumulated water to flow out.

For sanitation purposes, it may be necessary to seal the base of the cabinet to the floor. This can be accomplished by laying a bead of silicone sealant along the base of the cabinet as shown by the figure to the right.

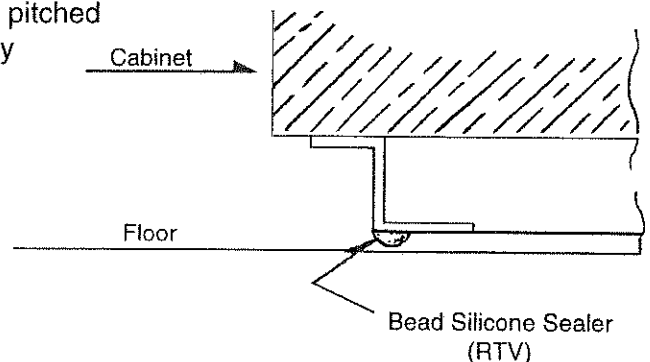

HOW TO OPERATE

ROLL TOP BOTTLE COOLERS

TEMPERATURE CONTROL

An adjustable temperature control is located inside the bottle cooler on the evaporator fan panel assembly. It is factory set at approximately 38° F. Make adjustments as shown to attain the desired temperature.

Note: A temperature setting that is too low will not allow enough condensing unit "off" time to maintain a frost-free coil.

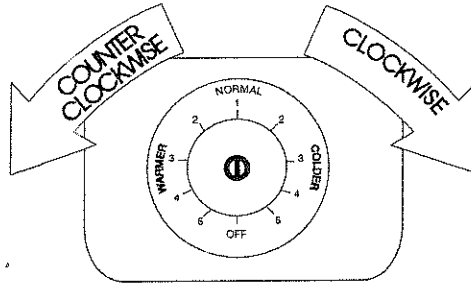

CLEANING

Condenser

The condenser (located behind the front grille) should be inspected every 30 days, and cleaned, if necessary. Failure to keep the condenser clean will cause a loss in condensing unit efficiency.

Doors

Doors should be periodically removed from the cabinet and inspected for a buildup of foreign materials, such as syrups, beer, etc. Buildups on the underside of the doors, along with the cabinet breaker strips on which they ride, will cause them to bind, and therefore, not function as designed. If dirty, these surfaces should be cleaned with a silicone lubricating material. Aerosol silicone sprays can be obtained locally at most department or automotive stores.

To remove doors: Lift front of door upward and slide forward until door clears the cabinet top. Use the reverse procedure to reinstall the doors.

Cabinet

Use a damp cloth with a mild detergent and water to clean the inside and outside of the cabinet. Dry thoroughly. Do not allow cleaning agents or large amounts of water to go down the drain. Use an acceptable stainless steel polish to clean all stainless steel surfaces (see pg. 7).

REPLACEMENT PARTS

ROLL TOP BOTTLE COOLERS

Parts Common to All Roll Top Bottle Coolers

Cap Opener & Receiver Assembly

Part No.	Description
C31088BL	Black
C31088SS	Stainless steel

Cap Opener Only

Part No.	Description
C15909	Cap Opener

Cap Receiver Only

Part No.	Description
C17332AL	Aluminum
C17332BL	Black
C17332SS	Stainless steel

C11279	Door Assembly with lock
C16038-1	Door gasket - front
C6661-1	Door gasket - back
C22258R	Replacement lock kit
C16037-1	Left wire partition
C8485-1	Center partition
C8484-1*	Main wire partition
C8487-1	Left bottom rack
C16325-1	Main bottom rack
C6757-1	Bin sub-divider
C4963-1	Breaker strip - right front
C4963-2	Breaker strip - left front
C9774	Center door mullion - stl. stl.
C7190-1	Door end rail - stl. stl.
C30313-1	Front grille
C30008-1	Condensate pan
C12829PG	Temperature control

*For Model Nos. 9277 & 9278 Only.

For 9276A-UL 2 Door Roll Top Bottle Coolers

Part No.	Description	Part No.	Description
57500	Compressor - R134a	C10510	Complete evaporator assy.
57513	Condenser fan motor	C8467	Fin coil assy.
C3150-3	Condenser fan blade	C6147	Evaporator fan blade
C12545A	Evaporator fan motor	C32207-1	Wire harness assy.
C25397-1	Evaporator fan guard		

For 9277A-UL 3 Door Roll Top Bottle Coolers

Part No.	Description	Part No.	Description
57498	Compressor - R134a	C10511	Complete evaporator assy.
57513	Condenser fan motor	C8469	Fin coil assy.
C3150-3	Condenser fan blade	C6154	Evaporator fan blade
C12546A	Evaporator fan motor	C32207-1	Wire harness assy.
C25397-1	Evaporator fan guard		

For 9278A-UL 4 Door Roll Top Bottle Coolers

Part No.	Description	Part No.	Description
57597	Compressor - R134a	C5934A	Complete evaporator assy.
C15250A2	Condenser fan motor	C8474A	Fin coil assy.
C15250A3	Condenser fan blade	C6159	Evaporator fan blade
C12546A	Evaporator fan motor	C32208-1	Wire harness assy.
C25401-1	Evaporator fan guard		

CLEANING STAINLESS STEEL

ROLL TOP BOTTLE COOLERS

AVOIDING STAINLESS STEEL CORROSION

Corrosion can be prevented by following product cautions, cleaning instructions and avoiding use of certain chemicals or objects which will cause stainless steel corrosion.

Stainless Steel Enemy	Result
Steel wool or steel scouring pads	Small particles break off, lodging in the surface and rusting begins.
Cherry/Onion/Olive juice	Sets up a galvanic action that can transfer enough metal to cause pin hole leaks.
Chlorine Bleach	Bar rags soaked in bleach and thrown into a stainless steel sink will cause the stainless to develop pin hole leaks after a very short period of time.
Sharp objects	Dropped into a stainless steel sink will cause a puncture dimple and over time will appear as a pin hole leak.

RECOMMENDED CLEANING AGENTS

Job	Cleaning Agent*	Comments
Routine Cleaning	Soap, ammonia, detergent	Apply with sponge or cloth. Can be used on all finishes.
Fingerprints and smears	Areal 20, Lac-O-Nu, Lumin Wash O'Cedar Cream Polish, Stainless	Provides barrier film to minimize fingerprints. Can be used on all finishes.
Stubborn stains and Discolorations	Allchem Concentrated Cleaner, Samae, Twinkle, Zud Restoro, Grade F or FFF Italian Pumice, Whiting or Talc, Liquid Nu Steel, Copper's or Revere Stainless Steel Cleaner, Lumin Cleaner, Sta-Clean, Cameo Copper Cleaner, Allen Polish Highlite, Penny-Brite, Copper Brite	Rub lightly, using dry or damp cloth in the direction of polish lines on the stainless steel.

**Use of propriety names is intended only to indicate a type of cleaner and does not constitute an endorsement. Omission of any proprietary cleaner does not imply its inadequacy. All products should be used in strict accordance with instructions on the package.*

WIRING DIAGRAM

ROLL TOP BOTTLE COOLERS

