

# VCT-20/25/50

## *Vertical Contact Toaster*

## owner's manual

### **Manufacturing Numbers:**

9200560, 9200600, 9200602, 9200606, 9200608,  
9200609, 9200614, 9200616, 9200620, 9200622,  
9200624, 9200625, 9200626, 9200628, 9200629,  
9200630, 9200631, 9200632, 9200634, 9200637,  
9200638, 9200639, 9200640

# VERTICAL CONTACT TOASTER

## TABLE OF CONTENTS

<b>Owner Information</b> .....	<b>2</b>	<b>Operation</b> .....	<b>9</b>
General .....	2	Operating Instructions .....	9
Warranty Information .....	2	Safety Features .....	9
Service/Technical Assistance .....	3	<b>Maintenance</b> .....	<b>10</b>
<b>Important Safety Information</b> .....	<b>3</b>	Daily.....	10
<b>Specifications</b> .....	<b>5</b>	Conveyor Belt Chains.....	11
Electrical Cord & Plug Configurations .....	5	Replacing Spring Tensioners.....	12
Model Designation.....	5	Replacing Conveyor Motor and Fan Blade .....	12
Electrical Ratings.....	5	<b>Troubleshooting</b> .....	<b>13</b>
Dimensions.....	6	<b>Wiring Diagram</b> .....	<b>19</b>
<b>Installation</b> .....	<b>7</b>	<b>Replacement Parts</b> .....	<b>20</b>
Unpacking.....	7	<b>Optional Parts – VCT-25 &amp; VCT-50</b> .....	<b>25</b>
Assembling the Unit .....	7	<b>Notes</b> .....	<b>26</b>
Equipment Setup .....	8	<b>Limited Warranty</b> .....	<b>Back Cover</b>

## OWNER INFORMATION

### General

The Vertical Contact Toaster, Models VCT-20, VCT-25 and VCT-50 are designed for contact toasting of buns. The toaster design allows the operator to place buns on both sides of the heated platen at the same time. Buns are placed into the top of the toaster and uniform, golden brown, warm buns are then retrieved at the bottom of the toaster. The Model VCT-20 is equipped with an auxiliary heating system which provides additional heat to the buns.

This manual provides the safety, installation and operating procedures for the Vertical Contact Toaster. We recommend that all information contained in this manual be read prior to installing and operating the unit.

Your Vertical Contact Toaster is manufactured from the finest materials available and is assembled to our strict quality standards. This unit has been tested at the factory to ensure dependable trouble-free operation.

### Warranty Information

Please read the full text of the Limited Warranty in this manual.

If the unit arrives damaged, contact the carrier immediately and file a damage claim with them. Save all packing materials when filing a claim. Freight damage claims are the responsibility of the purchaser and are not covered under warranty.

The warranty does not extend to:

- Damages caused in shipment or damage as result of improper use.
- Installation of electrical service.
- Normal maintenance as outlined in this manual.
- Malfunction resulting from improper maintenance.
- Damage caused by abuse or careless handling.
- Damage from moisture into electrical components
- Damage from tampering with, removal of, or changing any preset control or safety device.

**IMPORTANT!** Keep these instructions for future reference. If the unit changes ownership, be sure this manual accompanies the equipment.

## OWNER INFORMATION (continued)

### Service/Technical Assistance

If you experience any problems with the installation or operation of your unit, contact Antunes Technical Service.

Fill in the information below and have it handy when calling Antunes Technical Service for assistance. The serial number is on the specification plate located on the rear of the unit.

Purchased From: \_\_\_\_\_

Date of Purchase: \_\_\_\_\_

Model No.: \_\_\_\_\_

Serial No.: \_\_\_\_\_

Mfg. No.: \_\_\_\_\_

Use only genuine Antunes replacement parts in this unit. Use of replacement parts other than those supplied by the manufacturer will void the warranty.

You may contact Antunes Technical Service at 1-877-392-7854

## IMPORTANT SAFETY INFORMATION

Throughout this manual, you will find the following safety words and symbols that signify important safety issues with regards to operating or maintaining the equipment.



**WARNING**

**GENERAL WARNING.** Indicates information important to the proper operation of the equipment. Failure to observe may result in damage to the equipment and/or severe bodily injury or death.



**WARNING**

**ELECTRICAL WARNING.** Indicates information relating to possible shock hazard. Failure to observe may result in damage to the equipment and/or severe bodily injury or death.



**CAUTION**

**GENERAL CAUTION.** Indicates information important to the proper operation of the equipment. Failure to observe may result in damage to the equipment.



**WARNING**

**HOT SURFACE WARNING.** Indicates information important to the handling of equipment and parts. Failure to observe caution could result in personal injury.

A.J. Antunes & Co. reserves the right to change specifications and product design without notice. Such revisions do not entitle the buyer to corresponding changes, improvements, additions or replacements for previously purchased equipment.

# VERTICAL CONTACT TOASTER

## IMPORTANT SAFETY INFORMATION (continued)

In addition to the warnings and cautions in this manual, use the following guidelines for safe operation of the unit.

- Read all instructions before using equipment.
- For your safety, the equipment is furnished with a properly grounded cord connector. Do not attempt to defeat the grounded connector.
- Install or locate the equipment only for its intended use as described in this manual. Do not use corrosive chemicals in this equipment.
- Do not operate this equipment if it has a damaged cord or plug, if it is not working properly, or if it has been damaged or dropped.
- This equipment should be serviced by qualified personnel only. Contact Antunes Technical Service for adjustment or repair.
- Do not block or cover any openings on the unit.
- Do not immerse cord or plug in water.
- Keep cord away from heated surfaces.
- Do not allow cord to hang over edge of table or counter.

The following warnings and cautions appear throughout this manual and should be carefully observed.

- Turn the unit off, disconnect the power source and allow unit to cool down before performing any service or maintenance on the unit.
- The procedures in this chapter may include the use of chemical products. These chemical products will be highlighted with bold face letters followed by the abbreviated HCS (Hazard Communication Standard). See Hazard Communication Standard manual for the appropriate Material Safety Data Sheets (MSDS).

- The toaster should be grounded according to local electrical codes to prevent the possibility of electrical shock. It requires a grounded receptacle with separate electrical lines, protected by fuses or circuit breaker of the proper rating.
- Bread may burn. Therefore toasters must not be used near or below curtains or other combustible walls and materials. Failure to maintain safe operating distances may cause discoloration or combustion.
- Failure to use release sheets may result in damage to the equipment and loss of warranty coverage.
- All electrical connections must be in accordance with local electrical codes and any other applicable codes.
- **WARNING ELECTRICAL SHOCK HAZARD. FAILURE TO FOLLOW THESE INSTRUCTIONS COULD RESULT IN SERIOUS INJURY OR DEATH.**
  - Electrical ground is required on this appliance.
  - Do not modify the power supply cord plug. If it does not fit the outlet, have a proper outlet installed by a qualified electrician.
  - Do not use an extension cord with this appliance.
  - Check with a qualified electrician if you are in doubt as to whether the appliance is properly grounded.

# VERTICAL CONTACT TOASTER

## SPECIFICATIONS

### Electrical Ratings and Plug Configurations

Model & Mfg. No.	Volts	Watts	Amps	Hz	Plug Description	
VCT-50 9200609	208-240	2600- 3460	12.5-14.4	50/60	IEC-309, 16 Amp., 250 VAC Pin & Sleeve (Assembly Only)	
VCT-25 9200637	208-240	2600- 3460	12.5-14.4	50/60		
VCT-50 9200602	120	1760	14.7	60	5-20P, 20 Amp., 120 VAC Non-Locking (Assembly Only)	
VCT-25 9200622	120	1760	14.7	60		
VCT-50 9200606	208-240	2600- 3460	12.5-14.4	50/60	6-20P, 20 Amp., 250 VAC Non-Locking (Assembly Only)	
VCT-50 9200614	208-240	2600- 3460	12.5-14.4	50/60		
VCT-25 9200626	208-240	2600- 3460	12.5-14.4	50/60		
VCT-25 9200632	208-240	2600- 3460	12.5-14.4	50/60		
VCT-50 9200608	208-240	2600- 3460	12.5-14.4	50/60	CEE 7/7, 16 Amp., 250 VAC (Assembly Only)	
VCT-50 9200616	208-240	2600- 3460	12.5-14.4	50/60		
VCT-25 9200625	208-240	2600- 3460	12.5-14.4	50/60		
VCT-25 9200628	208-240	2600- 3460	12.5-14.4	50/60		
VCT-25 9200629	208-240	2600- 3460	12.5-14.4	50/60		
VCT-25 9200634	208-240	2600- 3460	12.5-14.4	50/60		
VCT-25 9200639	230	3460	15	50/60		
VCT-25 9200640	230	2450	10.6	50/60		
VCT-50 9200600	120	1760	14.7	60		5-15P, 15 Amp., 120 VAC Non-Locking (Assembly Only)
VCT-25 9200620	120	1760	14.7	60		
VCT-25 9200624	120	1760	14.7	60		
VCT-25 9200630	120	1760	14.7	60		
VCT-25 9200631	208-240	2600- 3460	12.5-14.4	50/60		
VCT-25 9200638	208-240	2600- 3460	12.5-14.4	50/60		
VCT-20 9200560	280-240	3200- 4257	15.4-17.3	50/60	LS-30P, 30 Amp., 120 VAC Straight Twist Lock	

# VERTICAL CONTACT TOASTER

## SPECIFICATIONS (continued)

### Dimensions

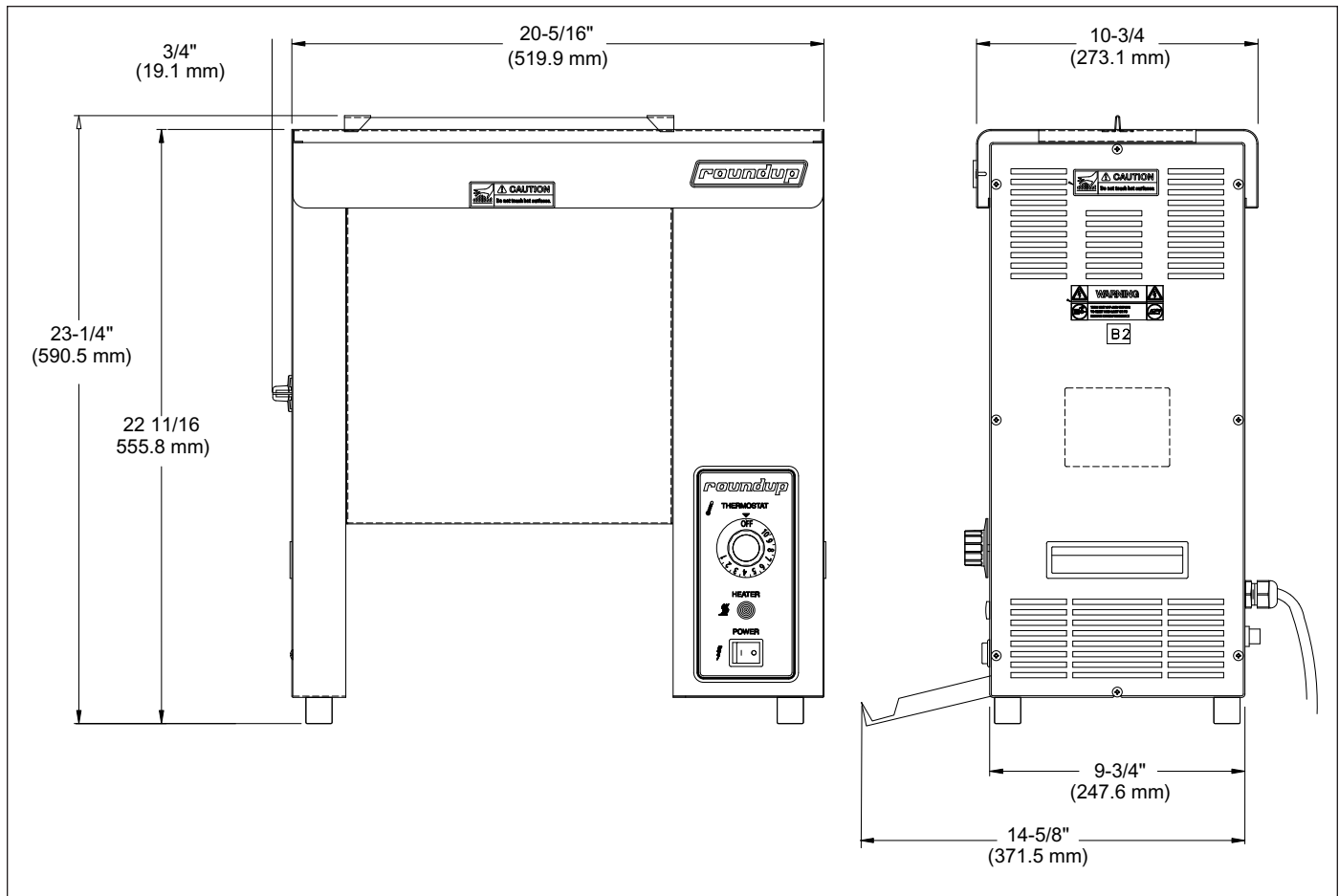

## INSTALLATION

### Unpacking

1. Remove unit and all packing materials from shipping carton.
2. Open the large box. It should contain:
  - Bun chute (Figure 2)
  - Plastic bag containing the release sheet (Figure 4)
3. Remove all packing materials and protective coverings from the unit and parts.

**NOTE: If any parts are missing or damaged, contact Antunes Technical Service IMMEDIATELY at 1-877-7854-392.**

### Assembling the Unit

1. Remove the Heat Shield and the front and rear Conveyor Covers (Figure 1).
2. Install the Damper Assembly. (Figure 1).

**NOTE: Make sure the damper assy. rests only on the bottom front and rear yellow support rods.**

3. Install the Bun Chute (Figure 2).
4. Remove the Release Sheet from the plastic bag and lay it on a clean, flat surface. Fold the sheet exactly in half (Figure 3).
5. Crease the sheet at the fold using only your finger (Figure 3).

**NOTE: Do not use metal tools to crease the sheet.**

6. Install the Release Sheet by draping it over both sides of the Platen surface. The crease should be centered directly on top of the Platen (Figure 4).

#### ⚠ CAUTION ⚠

**Failure to use release sheets may result in damage to the unit and loss of warranty coverage.**

7. Re-install the front and rear Conveyor Covers (Figure 4).

**IMPORTANT: Make sure the Conveyor Covers rest only on both the top and bottom yellow support rods.**

8. Install the Heat Shield so that the clips fit over the top of the Platen and retains the Release Sheet in place (Figure 4).

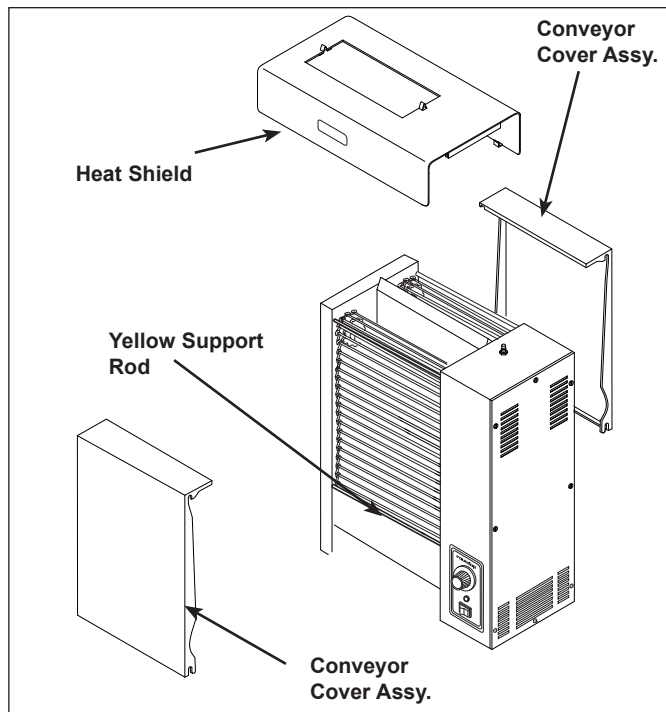

Figure 1. Installing Damper Assy.

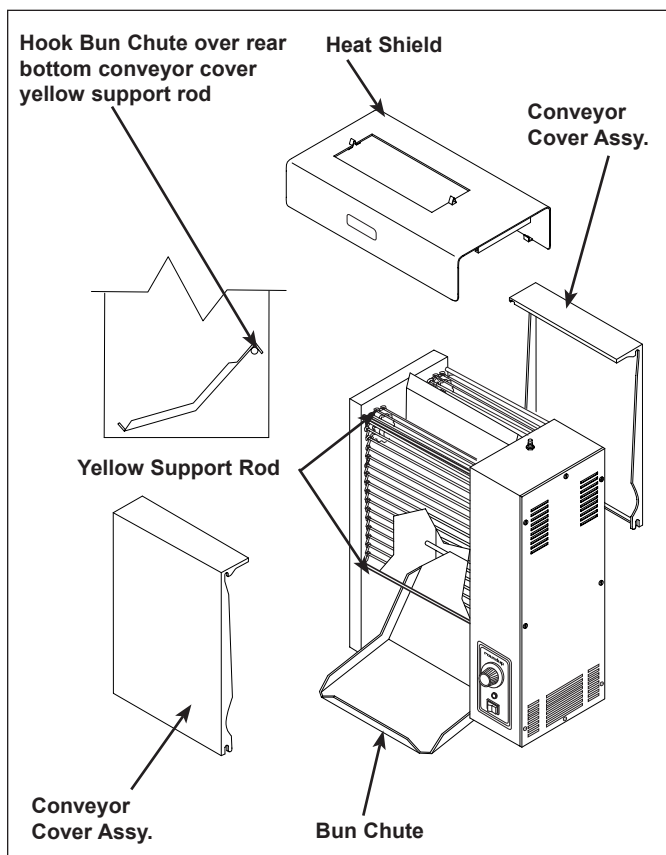

Figure 2. Installing Bun Chute





## OPERATION

### Operating Instructions

1. Set the Bun Thickness Adjustment Control knobs to the desired settings (Figure 6). The recommended setting is 6.

**NOTE: After initial run of 4-6 buns, adjust controls according to the desired finished product.**

2. Turn the Rocker Switch (power On/Off) to ON (Figure 5).
3. Turn the Temperature Control to 10. Allow 30 minutes warm-up time before proceeding.
4. Drop buns into toaster with the cut sides of heel and crown facing each other (Figure 5).
5. Toasted product will drop into the Bun Landing Area (Figure 5).
6. Test at least 4 buns before putting toaster into service. Turn the Temperature Control to a lower setting for lighter toasting or to a higher setting for darker toasting.
7. Turn the unit off when finished toasting.

### Safety Features

#### HI-LIMIT RESET BUTTON

A hi-limit thermostat will turn off electrical power to the heater and control circuits if the unit overheats. To reset this thermostat, allow sufficient time (10-15 minutes) for the unit to cool down, then press and release reset button located at the rear of the unit (Figure 5).

If the unit requires continuous resetting, contact your Authorized Service Agency.

#### CONVEYOR INTERLOCK SAFETY SWITCH

A Conveyor Interlock Safety Switch is located on top of the unit under the Heat Shield (Figure 4). The conveyors will not rotate unless the Heat Shield is properly in place and activating the Conveyor Interlock Safety Switch.

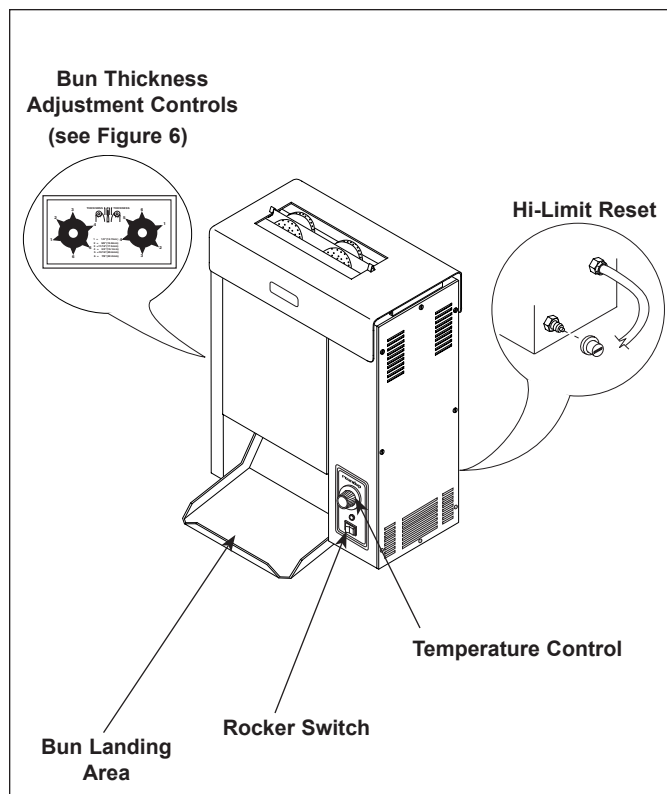

Figure 5. Toaster Controls

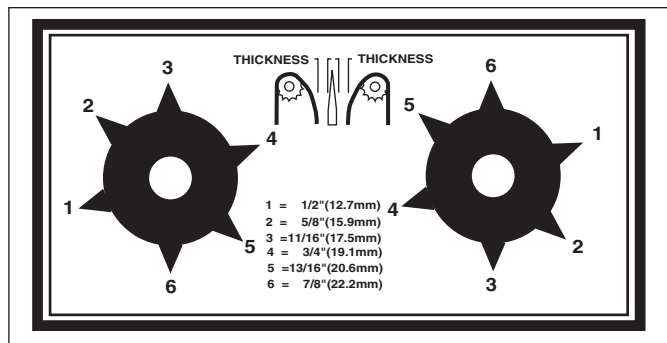

Figure 6. Bun Thickness Adjustment Controls







# VERTICAL CONTACT TOASTER

## TROUBLESHOOTING

### ▲ WARNING ▲

To avoid possible personal injury and/or damage to the unit, inspection, test and repair of electrical equipment should be performed by qualified service personnel. The unit should be unplugged when servicing, except when electrical tests are required. Use extreme care during electrical circuit tests. Live circuits will be exposed.

Problem	Possible Cause	Corrective Action
No heat and conveyor belts do not move.	Toaster is installed incorrectly.	Perform the installation and operating procedures found in the Installation section of this manual.
	Not enough voltage, defective power cord, defective rocker switch.	Check receptacle for correct voltage. See Specifications (page 5).  With unit plugged in and rocker switch on, check for correct voltage into rocker switch. If low or zero voltage, replace power cord. If voltage is correct, check for correct voltage out of rocker switch. If low or no voltage, replace rocker switch.
	Hi-limit switch tripped open.	Reset hi-limit switch (Fig. 5, page 9).
	Wiring problem.	Check all electrical connections for burns, discoloration or arcing. Replace all connections or components with damaged terminals. Replace all damaged wiring with the same (or higher) rated wire.
No heat and conveyor belts move.	Wiring problem.	Check all electrical connections for burns, discoloration or arcing. Replace all connections or components with damaged terminals. Replace all damaged wiring with the same (or higher) rated wire.
	Inoperative platen.	To check platen:  Use an Ohm meter to test resistance of the platen heater (disconnect 1 wire to isolate heater). Correct cold resistance for heating element of platen are as follows: 120 Volts, 1750 Watts - 7.8 Ohms 208 Volts, 2550 Watts - 16.2 Ohms 230 Volts, 1900 Watts - 26.5 Ohms  VCT-20 only. The auxiliary heaters are 144.2 Ohms at 208V/300 Watts.

# VERTICAL CONTACT TOASTER

## TROUBLESHOOTING (continued)

Problem	Possible Cause	Corrective Action
Platen is hot and the Conveyor Belt chains are not rotating.	Toaster is installed incorrectly.	Refer to the Installation and Operation sections of this manual for proper installation and operating procedures.
	Wiring problems.	Check all electrical connections for burns, discoloration or arcing. Replace all connections or components with damaged terminals. Replace all damaged wiring with the same (or higher) rated wire.
	Drive motor inoperable or incorrect conveyor drive motor.	To check drive motor: <ol style="list-style-type: none"> <li>1. Measure resistance of motor coil. Replace motor if coil measures either open circuit or zero resistance.</li> <li>2. Mark the drive motor sprocket and count the turns per minute. Correct drive motor speed is nine (9) turns per minute for VCT-20; three (3) turns per minute for VCT-25; one (1) turn per minute for VCT-50.</li> </ol>
	Broken Drive Chain or loose sprocket.	Check the Drive Chain for kinks, broken or bent links, or other damage. Check the motor sprocket and drive sprockets (on drive shaft); tighten setscrew on flat of shaft if required. Check for damaged/worn sprockets and replace as required.
	Heat Shield not installed or installed incorrectly.	Install the Heat Shield so that it activates the Conveyor Interlock Safety Switch.
	Conveyor Belt chains installed incorrectly.	Install the Conveyor Belt chains according to the Maintenance Section of this manual. Be sure that ends of the hooks are facing down.
	Conveyor Interlock Safety Switch is not activated.	Install the Heat Shield so that it activates the Conveyor Interlock Safety Switch.
	Spring Tensioner Assembly or Tensioner bent or missing.	Replace the Spring Tensioner assembly(s) (item 29, page 22) or Tensioners (item 4, page 24) if damaged or loose. Replace the Slide Rails (item 40, page 24) if worn or missing.
	Conveyor Belt chains too loose or missing links (41 links required when new). When new, conveyor has 37 large links and 4 small links.	Adjust or replace the Conveyor Belt chains according to the Maintenance section of this manual.

# VERTICAL CONTACT TOASTER

## TROUBLESHOOTING (continued)

Problem	Possible Cause	Corrective Action
Product is over-toasted, Platen heat is too high, or drop time is too slow	Temperature set too high.	Set temperature control at a lower setting.
	Bun Thickness Adjustment Control knobs set incorrectly.	Measure bun thickness and set bun adjustment controls correctly (Fig. 6, page 9).
	Buns sticking on Release Sheet.	Clean or replace the Release Sheet or conveyor belt wrap.
	Conveyor Covers not installed.	Install the Conveyor Covers.
	Conveyor Belts chains installed incorrectly	Install conveyor belt to match diagram in Fig. 8 (page 11). Be sure that ends of the hooks are facing down.
	Defective Platen.	To check platen:  Use an Ohm meter to test resistance of the platen heater (disconnect 1 wire to isolate heater). Correct cold resistance for heating element of platen are as follows: 120 Volts, 1750 Watts - 7.8 Ohms 208 Volts, 2550 Watts - 16.2 Ohms 230 Volts, 1900 Watts - 26.5 Ohms  VCT-20 only. The auxiliary heaters are 144.2 Ohms at 208V/300 Watts.
	Defective or wrong drive motor.	To check drive motor:  1. Measure resistance of motor coil. Replace motor if coil measures either open circuit or zero resistance.  2. Mark the drive motor sprocket and count the turns per minute. Correct drive motor speed is nine (9) turns per minute for VCT-20; three (3) turns per minute for VCT-25; one (1) turn per minute for VCT-50.
	Defective Drive Chain or loose sprocket.	Check drive chain for kinks, broken or bent links or other damage. Check motor sprocket and drive sprockets (on drive shaft); tighten setscrew on flat of shaft if required. Check for damaged/worn sprockets and replace as required.
Wiring problem.	Check all electrical connections for burns, discoloration or arcing. Replace all connections or components with damaged terminals. Replace all damaged wiring with the same (or higher) rated wire.	
Conveyor belt too loose or missing links (41 links required when new). When new, conveyor has 37 large links and 4 small links.	Remove conveyor belt (page 11). Lay belt flat and count links. Replace entire belt if links are damaged. If conveyor belt has too much play, it will jam. Adjust belt length as described under Servicing the Conveyor Belt (page 10).	

# VERTICAL CONTACT TOASTER

## TROUBLESHOOTING(continued)

Problem	Possible Cause	Corrective Action
Product is over-toasted or platen heat is too high or drop time is too slow. (continued).	Spring tensioner assy(s). or tensioner bent or missing.	Replace spring tensioner assy(s). (29, page 20) or tensioners (4, page 24) if damaged or loose. Replace slide rails (40, page 24) if worn or missing.
	Bun adjustment controls set incorrectly.	Measure bun thickness and set bun adjustment controls correctly (page 9).
Product is under toasted or platen heat is too low or drop time is too fast.	Not enough voltage, defective power cord, defective rocker switch.	Confirm platen temperature reading with a pyrometer or other temperature source.  Check receptacle for correct voltage. See Specifications (page 5).  With unit plugged in and rocker switch on, check for correct voltage into rocker switch. If low or zero voltage, replace power cord. If voltage is correct, check for correct voltage out of rocker switch. If low or no voltage, replace rocker switch.
	Wiring problem.	Check all electrical connections for burns, discoloration or arcing. Replace all connections or components with damaged terminals. Replace all damaged wiring with the same (or higher) rated wire.
	Platen inoperative.	To check platen:  Use an Ohm meter to test resistance of the platen heater (disconnect 1 wire to isolate heater). Correct cold resistance for heating element of platen are as follows: 120 Volts, 1750 Watts - 7.8 Ohms 208 Volts, 2550 Watts - 16.2 Ohms 230 Volts, 1900 Watts - 26.5 Ohms VCT-20 only. The auxiliary heaters are 144.2 Ohms at 208V/300 Watts.
	Conveyor drive motor inoperative or incorrect conveyor motor installed in toaster.	To check drive motor:  1. Measure resistance of motor coil. Replace motor if coil measures either open circuit or zero resistance.  2. Mark the drive motor sprocket and count the turns per minute. Correct drive motor speed is nine (9) turns per minute for VCT-20; three (3) turns per minute for VCT-25; one (1) turn per minute for VCT-50.
Product is getting stuck or conveyor belts stop when product is toasting.	Bun adjustment controls set incorrectly.	Measure bun thickness and set bun adjustment controls correctly (page 9).
	Conveyor release sheet not clean or missing.	Clean respective items. Refer to Maintenance Schedule (page 10).



# VERTICAL CONTACT TOASTER

## TROUBLESHOOTING (continued)

Problem	Possible Cause	Corrective Action
Product is getting stuck or conveyor belts stop when product is toasting (continued).	Not enough voltage, defective power cord or rocker switch.	Check receptacle for correct voltage. See Specifications (page 5).  With unit plugged in and rocker switch on, check for correct voltage into rocker switch. If low or zero voltage, replace power cord. If voltage is correct, check for correct voltage out of rocker switch. If low or no voltage, replace rocker switch.
	Wiring problem.	Check all electrical connections for burns, discoloration or arcing. Replace all connections or components with damaged terminals. Replace all damaged wiring with the same (or higher) rated wire.
	Conveyor drive motor inoperative or incorrect conveyor motor installed on toaster.	To check drive motor:  1. Measure resistance of motor coil. Replace motor if coil measures either open circuit or zero resistance.  2. Mark the drive motor sprocket and count the turns per minute. Correct drive motor speed is nine (9) turns per minute for VCT-20; three (3) turns per minute for VCT-25; one (1) turn per minute for VCT-50.
	Conveyor Belt chain is loose, worn, or broken or the motor drive sprocket is loose..	Check drive chain for kinks, broken or bent links or other damage. Check motor sprocket and drive sprockets (on drive shaft); tighten setscrew on flat of shaft if required. Check for damaged/worn sprockets and replace as required.
	The Conveyor Covers are not installed or are improperly installed.	Install conveyor cover assy(s).
	Conveyor Belts chains are installed incorrectly.	Install conveyor belt to match diagram in Fig. 8 (page 11). Be sure that ends of the hooks are facing down.
	Conveyor Belt Chains are too loose or are missing links (41 links required when new). When new, the Conveyor Belt chain has 37 large links and 4 small links.	Remove conveyor belt (page 11). Lay belt flat and count links. Replace entire belt if links are damaged. If conveyor belt has too much play, it will jam. Adjust belt length as described under Servicing the Conveyor Belt (page 11).
	The Spring Tensioners or Tensioners are bent or missing.	Replace spring tensioner assy(s). (29, page 22) or tensioners (4, page 24) if damaged or loose. Replace slide rails (40, page 24 worn or missing.

# VERTICAL CONTACT TOASTER

## TROUBLESHOOTING (continued)

Problem	Possible Cause	Corrective Action
Conveyor belts are "jumping" or "snapping".	Toaster is installed incorrectly.	Perform installation and operating procedures (pages 7-9).
	Bun adjustment controls set incorrectly.	Measure bun thickness and set bun adjustment controls correctly (page 9).
	Conveyor drive motor inoperative or incorrect conveyor motor installed on toaster.	To check drive motor:  1. Measure resistance of motor coil. Replace motor if coil measures either open circuit or zero resistance.  2. Mark the drive motor sprocket and count the turns per minute. Correct drive motor speed is nine (9) turns per minute for VCT-20; three (3) turns per minute for VCT-25; one (1) turn per minute for VCT-50.
	Conveyor drive chain loose, worn or broken. Loose motor drive sprocket.	Check drive chain for kinks, broken or bent links or other damage. Check motor sprocket and drive sprockets (on drive shaft); tighten setscrew on flat of shaft if required. Check for damaged/worn sprockets and replace as required.
	Conveyor belts installed incorrectly.	Install conveyor belt to match diagram in Fig. 8 (page 10). Be sure that ends of the hooks are facing down.
	Conveyor belt too loose or missing links (41 links required when new). When new, conveyor has 37 large links and 4 small links.	Remove conveyor belt (page 11). Lay belt flat and count links. Replace entire belt if links are damaged. If conveyor belt has too much play, it will jam. Adjust belt length as described under Servicing the Conveyor Belt (page 11).
	Spring tensioner assy(s) or tensioner bent or missing.	Replace spring tensioner assy(s). (29, page 22) or tensioners (4, page 24) if damaged or loose. Replace slide rails (40, page 24) worn or missing.
Crown and/or heel must be forced into toaster.	Heat shield improperly installed.	Remove and reposition heat shield.
	Crown and/or heel improperly inserted into toaster.	Buns must be inserted with cut faces facing each other; heel in front slot and crown in rear slot.

# VERTICAL CONTACT TOASTER

## WIRING DIAGRAM

### Pictorial Wiring Diagram VCT-20 WIRING DIAGRAM

NOTE: ALL WIRES TO BE 14 GA. AWM-105°C  
UNLESS OTHERWISE SPECIFIED.  
\* 16 GA. TFE-200°C  
= 18 GA. AWM-105°C  
# 16 GA. AWM-105°C  
% 14 GA. TFE-200°C

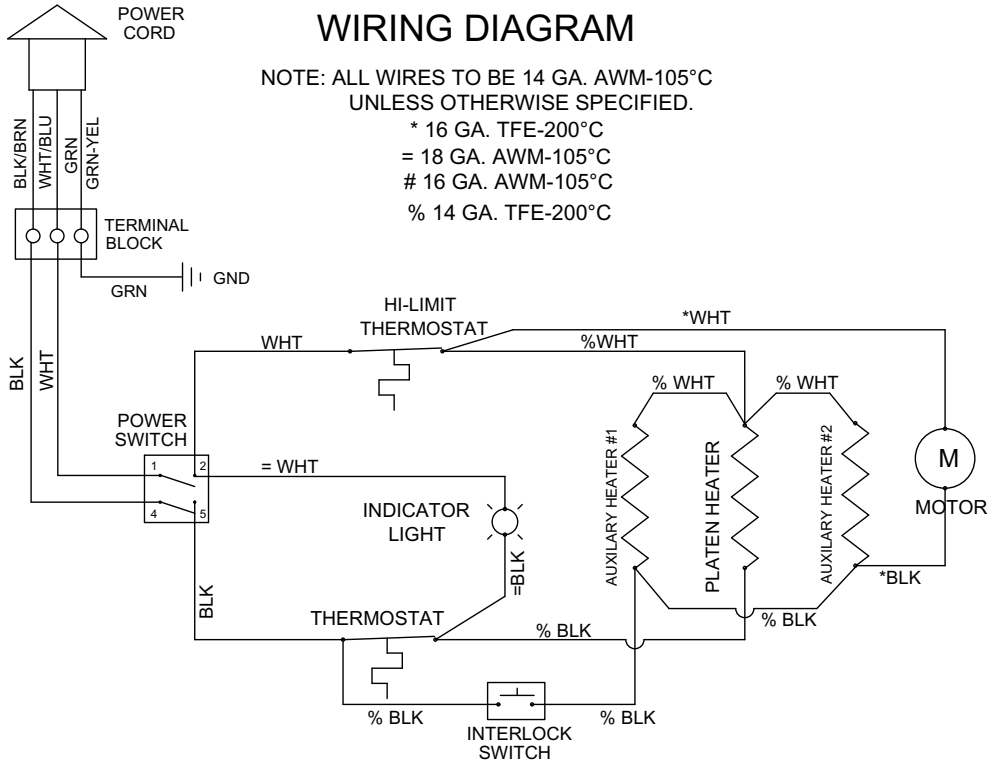

### Pictorial Wiring Diagram VCT-25 & VCT-50 WIRING DIAGRAM

NOTE: ALL WIRES TO BE 14 GA. AWM-105°C  
UNLESS OTHERWISE SPECIFIED.  
\* 16 GA. TFE-200°C  
= 18 GA. AWM-105°C  
# 16 GA. AWM-105°C  
% 14 GA. TFE-200°C

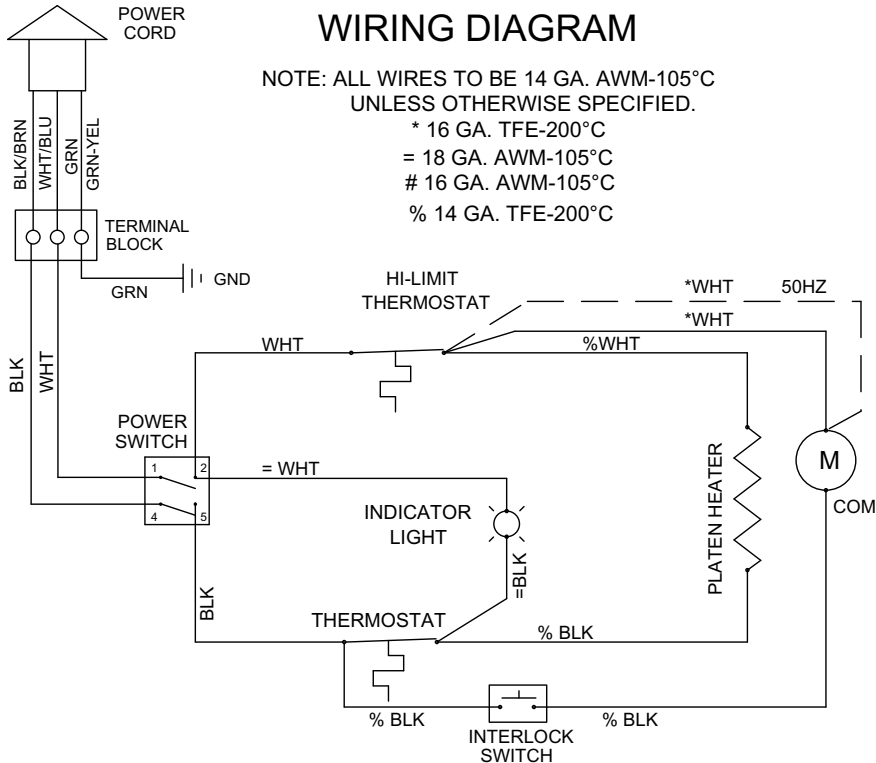

# VERTICAL CONTACT TOASTER

## REPLACEMENT PARTS

### Parts Identification

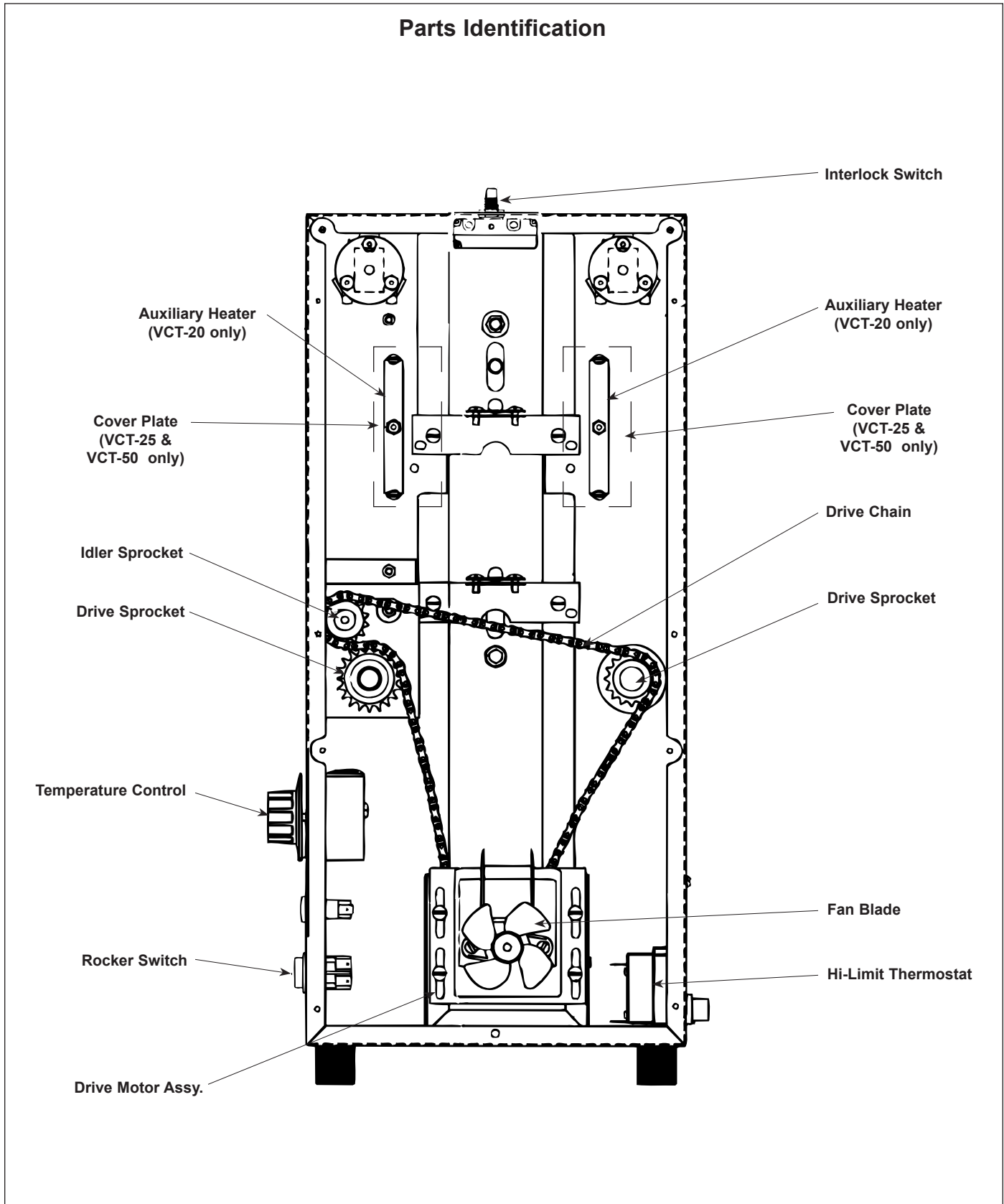

# VERTICAL CONTACT TOASTER

## REPLACEMENT PARTS (continued)

Item	Part No.	Description	Qty.	Item	Part No.	Description	Qty.
1	0011264	Conveyor Belt	2	36	2100133	Knob, Thermostat Control	1
	0800204	1/2" Pitch Link, Small	4	37	0021170	Weldment, End Housing	1
	0800121	3/4" Pitch Link, Large	37	38	7000249	Release Sheet (Pack of 3)	-
2	2150117	Idler Shaft	2		7000250	Release Sheet (Pack of 10)	-
3	0011375	Conveyor Cover Assy.	2	39	0021194	Weldment, Control Housing	1
4	0010475	Tensioner Assy. (Incl. #40, 76, 85)	4	40	7000121	Slide Rail Kit (Incl. Qty. 2 slide rails for tensioners)	2
5	0800332	Rod, Conveyor Cover	4	41	0021207	Conveyor Cam	2
6	2150190	Sprocket	8	42	7000176	Thermocouple Retainer Kit	2
7	7000199*	Spacer Kit	2	43	4030332	High Limit Thermostat	1
8	0503362	Control Cover	1	44	0400251	Strain Relief	1
9	2150118	Drive Shaft	2	45	0400138	Locknut, 1/2"	1
10	0700437	Power Cord Assy (2.5-16A) W/ IEC-309 Plug (Mfg. No. 9200609 & 9200637)	1	46	0503590	Bracket, Motor	1
	0700451	Power Cord 14/3 5-20P (Mfg. No. 9200602 & 9200622)	1	47	0070582	Wire Set, VCT-20 (not shown)	1
	0700452	Power Cord 14/3 6-20P (Mfg. No. 9200606, 9200614, 9200626 & 9200632)	1		0700586	Wire Set, VCT-25/VCT-25 (not shown)	1
	0700453	Power Cord - IntL/HARMZD W/ CEE 7/7 Plug (Mfg. No. 9200608, 9200616, 9200628, 9200628, 9200629, 9200634, 9200639, and 9200640)	1	48	0503385	Bun Chute	1
	0700463	Power Cord, 14/3 5-15P (Mfg. No. 9200600, 9200620, 9200624, 9200630, and 9200631)	1	49	4030313	Auxiliary Heater, 300W VCT-20 only MFG# 9200560	2
	0700552	Power Cord Assy Commercial/Plug L6-20P (Mfg. No. 9200560)	1	50	331P101*	Nut, Hex, 5/16 x 18"	1
11	4030235	Thermostat, 530° F	1	51	7000229	Platen (120 Volt)	1
	4030355	Thermostat, 122F-600F Adjustable (Mfg. No. 9300639 only)	1		7000200	Platen (208-240 Volt)	1
12	2150158	Ball Bearing	2		7000288	Platen (230 Volt) (Mfg. No. 9200640 only)	1
13	2150186	Bearing	6	52	2100266	Tape	2
14	0503459	Bearing Retainer/Spacer	6	53	4010107	Interlock Switch	1
15	0503376	Bearing Retainer	6	54	0503150	Heater Clip, VCT-20 only	2
16	7000167	Bearing & Retainer Kit (Includes #13, 14, 15 & 59)	1	57	0503608	Cover Plate	2
17	2150193	Drive Sprocket, VCT-20	2	58	4000165	Fan Blade, Motor	1
	2150109	Drive Sprocket, VCT-25/VCT-50	2	59	2100256	Tape, Hi-Temp	8
18	2150187	Drive Chain	1	61	212P118*	Flat Washer, 5/16"	1
19	0011299	Idler Sprocket & Bearing	1	62	0500464	Retainer, Bearing	1
20	0501232	Bracket, Idler Sprocket	1	64	0011330	Heat Shield Assy.	1
21	0503589	Bracket, Motor Mounting	1		7000707	Heat Shield with Dampers (Mfg. No. 9200629 Only)	1
22	7000204	Drive Motor Kit, VCT-20 (Incl. #58)	1		0013013	Heat Shield With Dampers (Mfg. No. 9200625 Only)	1
	400K150	Drive Motor Kit, VCT-50 (120V) (Incl. #58)	1	65	325P163	Setscrew, 1/4-28 x 5/16"	8
	400K151	Drive Motor Kit, VCT-50 (230V) (Incl. #58)	1	66	100P864*	Label, Caution Hot	1
	400K152	Drive Motor Kit, VCT-25 (120V) (Incl. #58)	1	67	308P154*	Screw, #10-32 x 3/8"	2
	400K153	Drive Motor Kit, VCT-25 (230V) (Incl. #58)	1	68	306P104*	Screw, #6-32 x 1/4"	8
23	2150173	Sprocket, Motor, VCT-20	1	69	406P107*	Cable Tie	1
	2150120	Sprocket, Motor, VCT-50	1	70	308P143*	Nut, #8-32, "KEPS"	6
	2150110	Sprocket, Motor, VCT-25	1	71	310P103*	Screw, #10-32 x 1/4"	4
24	7000882	Rocker Switch Kit, On/Off	1	72	310P140*	Washer, #10	6
25	4060355	Terminal Block	1	73	308P101*	Nut, #8-32	3
26	0503495	Retainer, Tension Bracket, RH	2	74	306P101*	Nut, Hex, #6-32	2
27	0503507	Retainer, Tension Bracket, LH	2	75	306P123*	Screw, #6-32 x 7/8"	2
28	4060229	Indicator Light, Amber (250V)	1	76	308P145*	Nut, Hex Acorn, #8-32	14
	4060323	Indicator Light, Amber (125V)	1	77	100P900*	Label, Service	1
29	0011374	Spring Tensioner Assy.	2	78	325P104*	Washer, 1/4"	4
30	0503496	Tensioner Bracket, Right	2	79	325P109*	Screw, 1/4-20 x 1/2"	4
31	0503497	Tensioner Bracket, Left	2	80	308P124*	Screw, 1-Way, #8-32 x 1/2"	1
32	1000899	Label, Control	1	81	210K230	Bumper, Recess Leg, 1"	4
33	10P1047*	Label, Dial (Pack of 10)	1	82	310P136*	Screw, #10-32 x 1-1/4"	4
34	2100253	Knob, Cam	2	83	308P133*	Screw, #8-32 x 1/4"	12
35	0503390	Cover, End Housing	1	84	308P151*	Screw, SEMS, #8-32 x 5/16"	4
				85	308P181*	Screw, Flat Hd., #8-32 x 3/8"	4
				86	218P145*	Cover, Leg, Bumper	4
				87	331P103*	Shoulder Bolt, 5/16-18 x 1"	1
				88	306P105*	Screw, #6-32 x 1/2"	1
				89	0503455	Tension Spring, Inner	4
				90	2100259	Slide Bar	4

\* Only available in packages of 10.

# VERTICAL CONTACT TOASTER

## REPLACEMENT PARTS (continued)

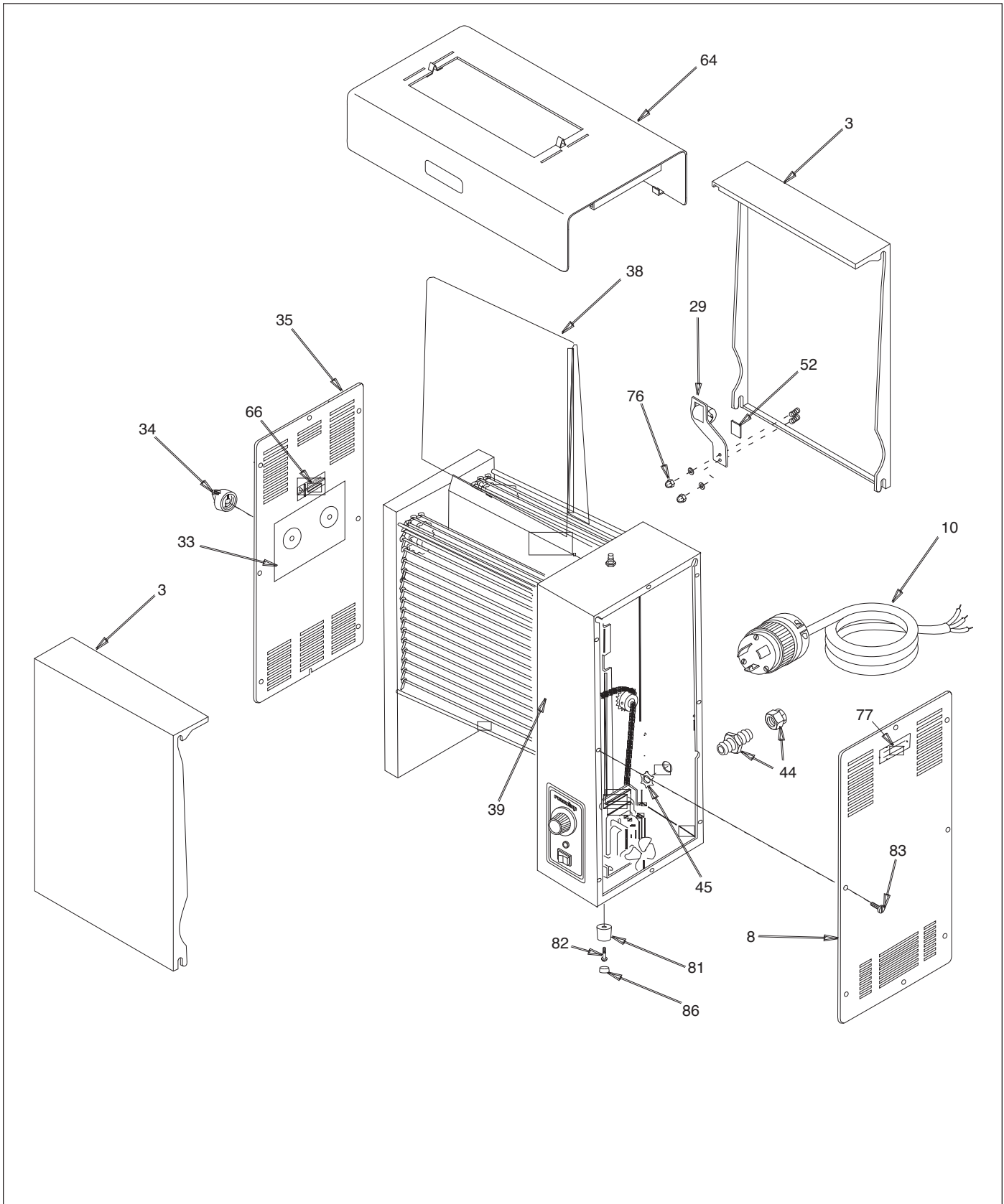

# VERTICAL CONTACT TOASTER

## REPLACEMENT PARTS (continued)

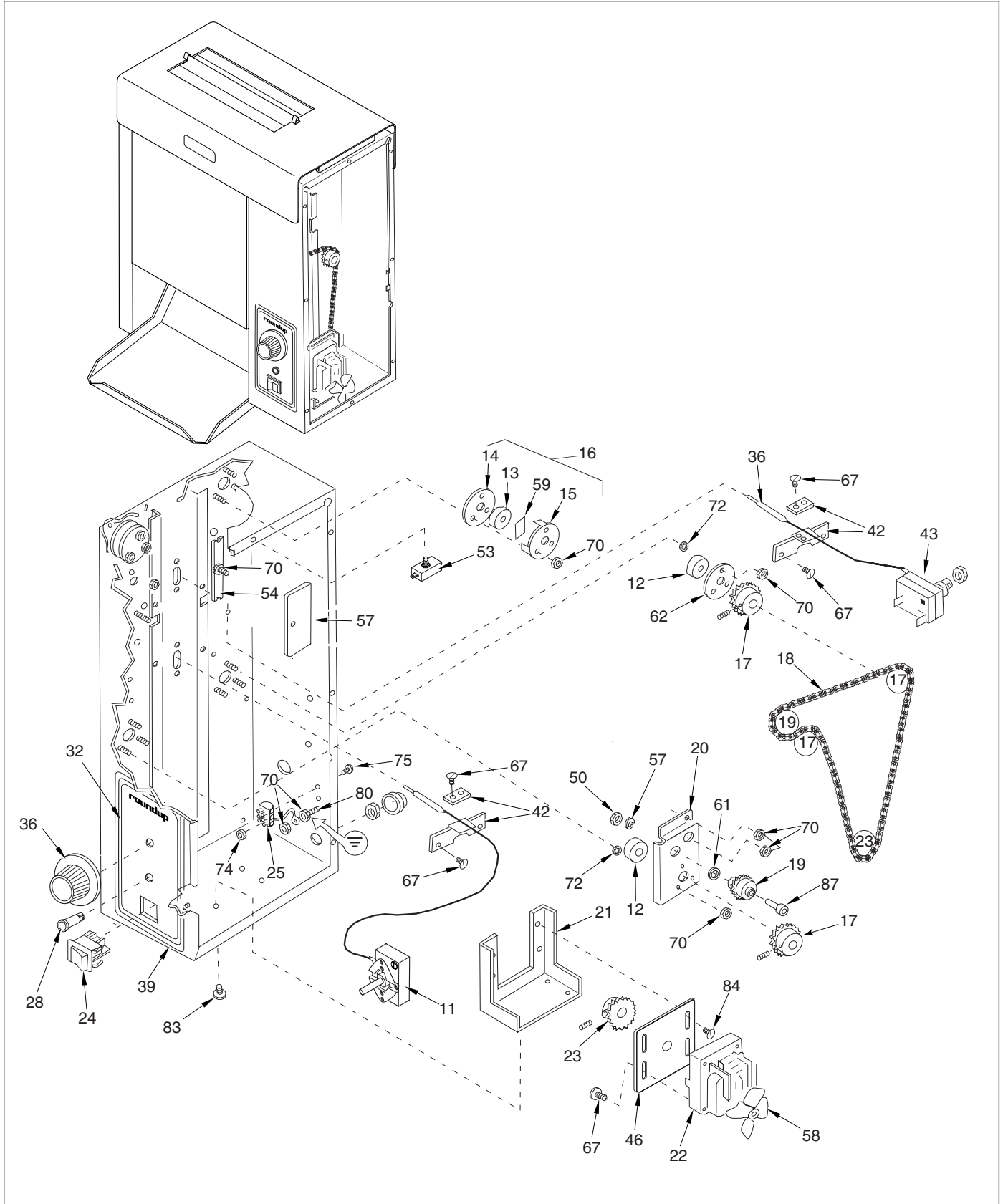

# VERTICAL CONTACT TOASTER

## REPLACEMENT PARTS (continued)

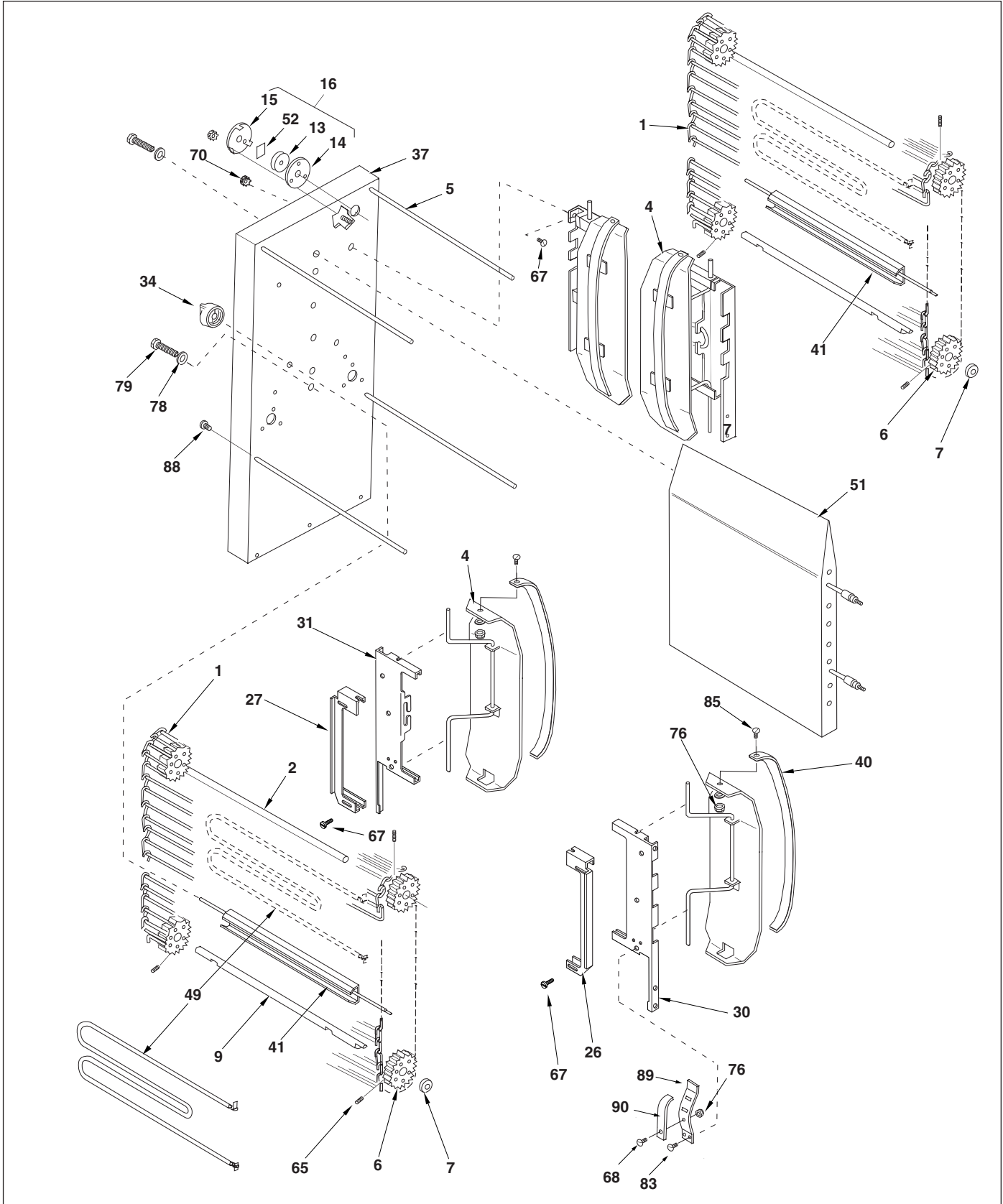



# VERTICAL CONTACT TOASTER

## OPTIONAL PARTS – VCT-25 & VCT-50

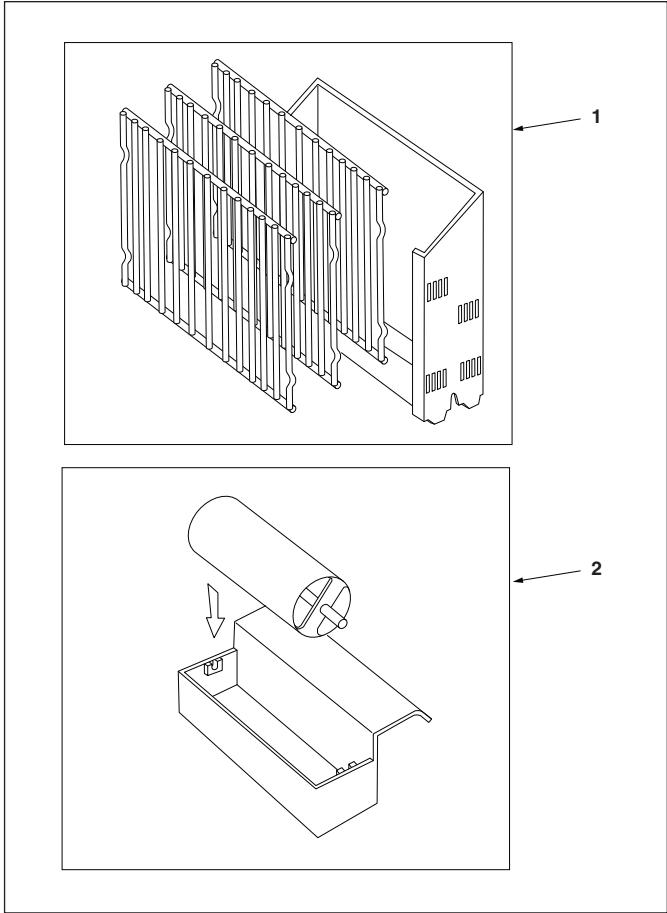

Item	Part No.	Description	Qty.
1	7000236	Bun Feeder	1
2	7000238	Butter Wheel Kit	1

**VERTICAL CONTACT TOASTER**

---

**NOTES**

Lined area for notes.



## LIMITED WARRANTY

Equipment manufactured by Roundup Food Equipment Division of A.J. Antunes & Co. has been constructed of the finest materials available and manufactured to high quality standards. These units are warranted to be free from electrical and mechanical defects for a period of one (1) year from date of purchase under normal use and service, and when installed in accordance with manufacturer's recommendations. To insure continued operation of the units, follow the maintenance procedures outlined in the Owner's Manual. During the first 12 months, electro-mechanical parts, non-overtime labor, and travel expenses up to 2 hours (100 miles/160 km), round trip from the nearest Authorized Service Center are covered.

1. This warranty does not cover cost of installation, defects caused by improper storage or handling prior to placing of the Equipment. This warranty does not cover overtime charges or work done by unauthorized service agencies or personnel. This warranty does not cover normal maintenance, calibration, or regular adjustments as specified in operating and maintenance instructions of this manual, and/or labor involved in moving adjacent objects to gain access to the equipment. This warranty does not cover consumable/wear items. This warranty does not cover damage to the Load Cell or Load Cell Assembly due to abuse, misuse, dropping of unit/shock loads or exceeding maximum weight capacity (4 lbs). This warranty does not cover water contamination problems such as foreign material in water lines or inside solenoid valves. It does not cover water pressure problems or failures resulting from improper/incorrect voltage supply. This warranty does not cover Travel Time & Mileage in excess of 2 hours (100 miles/160 km) round trip from the nearest authorized service agency.
2. Roundup reserves the right to make changes in design or add any improvements on any product. The right is always reserved to modify equipment because of factors beyond our control and government regulations. Changes to update equipment do not constitute a warranty charge.
3. If shipment is damaged in transit, the purchaser should make a claim directly upon the carrier. Careful inspection should be made of the shipment as soon as it arrives and visible damage should be noted upon the carrier's receipt. Damage should be reported to the carrier. This damage is not covered under this warranty.
4. Warranty charges do not include freight or foreign, excise, municipal or other sales or use taxes. All such freight and taxes are the responsibility of the purchaser.
5. THIS WARRANTY IS EXCLUSIVE AND IS IN LIEU OF ALL OTHER WARRANTIES, EXPRESSED OR IMPLIED, INCLUDING ANY IMPLIED WARRANTY OR MERCHANTABILITY OR FITNESS FOR A PARTICULAR PURPOSE, EACH OF WHICH IS HEREBY EXPRESSLY DISCLAIMED. THE REMEDIES DESCRIBED ABOVE ARE EXCLUSIVE AND IN NO EVENT SHALL ROUNDUP BE LIABLE FOR SPECIAL CONSEQUENTIAL OR INCIDENTAL DAMAGES FOR THE BREACH OR DELAY IN PERFORMANCE OF THIS WARRANTY.



### U.S. Headquarters

Carol Stream, Illinois

Phone: (630) 784-1000

Toll Free: (800) 253-2991

Fax: (630) 784-1650

### China Facility

Suzhou, China

Phone: 86-512-6841-3637

Toll Free: 86-512-6841-3907

Fax: 400-0-7878-22