



Star
Manufacturing
International, Inc.

10 Sunnen Drive
St. Louis, MO 63143

Phone: (314) 781-2777
Fax: (314) 781-3636

Installation
and
Operating
Instructions

2M-Z6393 Rev. A 1/28/03

STAR-MAX ELECTRIC GRIDDLES

MODELS

**515TGZ, 524TGZ, 536TGZ, 548TGZ,
524TGZS, 536TGZS**

CHROME-MAX ELECTRIC GRIDDLES

MODELS

524CHSZ, 536CHSZ, 548CHSZ



SAFETY SYMBOL



This symbol is intended to alert the user to the presence of important operating and maintenance instructions in the manual accompanying the appliance.

RETAIN THIS MANUAL FOR FUTURE REFERENCE

NOTICE

Using any part other than genuine Star factory supplied parts relieves the manufacturer of all liability.

NOTICE

Star reserves the right to change specifications and product design without notice. Such revisions do not entitle the buyer to corresponding changes, improvements, additions or replacements for previously purchased equipment.

MAINTENANCE AND REPAIRS

Contact your local authorized service agent for service or required maintenance. Refer to the authorized service center listing provided with the unit. The Star Service Help Desk (1-800-807-9054) is available during normal business hours to answer any questions that may arise. Please have your model number and serial number for faster service.



CAUTION

This equipment is designed and sold for commercial use only by personnel trained and experienced in its operation and is not sold for consumer use in and around the home nor for use directly by the general public in food service locations. For equipment to be used by the general public, please contact the factory.

INSTALLATION

The griddles are equipped for the voltage indicated on the nameplate mounted on the front panel. They will operate on alternating current (AC) only.



CAUTION

DO NOT CONNECT TO DIRECT CURRENT (DC).

The installation of the electric griddle should conform to the:

NATIONAL ELECTRIC CODE AND ALL LOCAL ELECTRIC CODES AND ORDINANCES AND THE LOCAL ELECTRIC COMPANY RULES AND REGULATIONS

For your protection we recommend that a qualified electrician install this griddle. He should be familiar with electrical installations and all electric codes. Proper connections and power supply are essential for efficient performance. The external wirings should be in conduit or an approved type of flexible cable suitable for operation at the temperature indicated on the wiring diagram, and of a proper size to carry the load. The supply circuit should be properly fused and equipped with a means of disconnecting, as required by local electrical code. **THE BODY OF THE GRIDDLE SHOULD BE GROUNDED (DO NOT GROUND TO A GAS SUPPLY LINE).**

GENERAL OPERATING PROCEDURES

The Chrome-Max and Star-Max series electric griddles may be wired for operation in the field for either 1-phase or 3-phase power supplies by making line connections at the junction box(es) located at the rear of the unit. Model 536TG should be wired for 3-phase power supply only. Two junction boxes are provided on the 548TG for making line connections. These may be connected in parallel to one 16KW 3-phase line or on two separate 8KW lines.

CONNECTING POWER SUPPLY

Detach cover on junction box at rear of unit. There are pigtail leads for wire nut connection in the junction box.

LOCATING AND LEVELING THE UNIT

Do not install the unit closer than 1-inch from a side wall and/or closer than 1-inch from a rear wall. Level unit by adjusting the (4) feet which have an adjustment of 1-3/4" (43.75mm) for accurate leveling and perfect line-up with other Star-Max series units.

SEASONING THE GRIDDLE HEATING SURFACE (NON CHROMIUM SURFACE)

Clean the griddle surface thoroughly. After the griddle has been thoroughly cleaned, it should be seasoned to prevent food from sticking. Before using and after each thorough scouring, season the griddle heating surface in the following manner.

1. Turn temperature control dials to 350° F (177°C).
2. Using a clean cloth, not a spatula, spread a thin film of cooking oil or fat over the griddle cooking surface. This film should remain on the hot griddle surface for half an hour.
3. Remove the excess fat and wipe clean.
4. Apply another film of cooking oil over the hot cooking area for another half hour and again remove excess fat and wipe clean. The griddle surface should now be ready for use.

Even with careful seasoning, food may, to some extent, stick to the griddle cooking surface until the griddle plate is broken in.

TEMPERATURE CONTROL

The temperature controls are combination "ON/OFF" switches and thermostats. Turning the dial knob automatically maintains the selected heat range.

The Star-Max/Chrome-Max electric griddle line has one thermostat for every 12" (30cm) section of griddle which operate independently of one another. Each thermostat controls the section of the griddle above it and may be set at different temperatures as desired.

COOKING

Set the thermostat dial knob at the temperature desired. After a short pre-heating period, the thermostat will automatically maintain the selected temperature.

IDLING

During idle periods, to save on operating costs, lower the temperature setting of the thermostat to about 250°F (121°C). It is not necessary to maintain cooking temperature during idle periods, as the griddle can quickly be reheated to the desired temperature.

SIGNAL LIGHTS

Each thermostat has its own signal light which indicates when the unit's control knob is not in the off position.

GRIDDLE CARE (NON-CHROMIUM SURFACES)

It takes very little time and effort to keep the griddle attractive and performing at top efficiency. If grease is permitted to accumulate, it will form a gummy cake and then carbonize into a hard substance which is extremely difficult to remove. To prevent this condition, the following suggestions for cleanliness should be followed:

1. After each use, scrape the griddle with a scraper or flexible spatula to remove excess fat and food. A waste drawer is provided for the scrapings. If there is an accumulation of burned on fat and food, the griddle should be thoroughly scoured and reseasoned. Use pumice or griddle stone while the griddle is warm. Do not use steel wool because of the danger of steel slivers getting into the food.

2. Daily, use a clean cloth and a good non-abrasive cleaner to clean the stainless steel body of the griddle. Wipe the polished front with a soft cloth.
3. At least once a day, remove the waste grease drawer and wash in the same way as an ordinary cooking utensil. The drawers are removed by pulling forward until they are released from their track.

GRIDDLE CARE (CHROMIUM SURFACES)

It takes very little time and effort to keep this Industrial Chromium griddle surface sparkling clean and performing at top efficiency. **DO NOT** allow grease to accumulate as it will carbonize and become difficult to remove. To prevent this condition the following cleaning suggestions should be followed:

1. Remove excess oil and food regularly with a 4" (100mm) wide **Razor Sharp** type scraper and wipe surface with a damp cloth if desired.
2. Following the scraping, for end of the day cleaning, a damp cloth and a non-silicated, non-abrasive, non-chlorinated cleaner such as Bon-Ami may be used to wipe surface clean, followed by wiping with a clean wet cloth.
3. Follow steps 2 and 3 from Griddle Care (Non-Chromium Surfaces) above.



CAUTION

1. **Never** use pumice, griddle stones, or abrasives on the surface.
2. **Never** strike griddle surface with sharp instrument or spatula edge.
3. **Never** use steel wool.
4. **Never** use commercial liquid grill cleaner on the griddle surface.
5. **Abusing** surface voids the warranty.

MAINTENANCE AND REPAIRS

Contact the factory, a service representative, or a local service company for service or required maintenance.

CHROME-MAX GRIDDLE SURFACE LIMITED WARRANTY EXCLUSIONS

Your Chrome-Max griddle has been designed to give you many years of cooking reliability and requires minimum maintenance to keep the chrome surface in its original condition. All Chrome-Max griddle surfaces are warranted for a period of 5 years against manufacturing defects to the original owner from the date of installation. This limited warranty is void if it is determined by Star Manufacturing International Incorporated or one of its authorized representatives that the chrome surface has been misused or abused or subjected to the following situations:

1. Improperly installed.
2. By-pass adjustments not set properly on gas units allowing the appliance to overheat and discolor the chrome surface. (See by-pass adjustment in instruction manual supplied with unit).
3. Incorrect voltage applied to electric Chrome-Max units allowing the surface to overheat and discolor.
4. The misuse of any instrument or tool which scratches or makes indentations in the surface which could cause the surface to peel, flake, or chip off.
5. The use of any chemical or abrasive cleaning solution, griddle brick, stone, screen or other cleaning products which could damage and affect the performance of the chrome surface.
6. The neglect of daily routine maintenance to the chromium surface.



STAR MANUFACTURING INTERNATIONAL INC.
#10 SUNNEN DRIVE, ST. LOUIS, MO. 63143, USA

MATERIAL

MODEL NO.

PART NO.

515TG

SK 1895

FINISH

TITLE WIRING DIAGRAM 15" ELEC. GRIDDLE

DR. PMR

CK.

DATE 5/21/02

REVISIONS

LTR

DATE

DESCRIPTION OF CHANGE

DR

TOLERANCES UNLESS OTHERWISE NOTED
FRACTIONS $\pm 1/64$ DECIMALS $\pm .005$ ANGLES $\pm 1^\circ$

THIS DRAWING CONTAINS INFORMATION CONFIDENTIAL TO STAR MFG. INT'L. INC.
NO REPRODUCTION OR DISCLOSURE OF ITS CONTENTS IS PERMITTED.

FOR SUPPLY CONNECTIONS
USE GAUGE SHOWN OR
LARGER

NOMINAL AMPS PER LINE WIRE

3,004 WATTS	4,000 WATTS
208V-1 PHASE	240V-1 PHASE
14.44	16.66
AWG #14	AWG #14

NOTE:

1) FOR SUPPLY CONNECTIONS
USE COPPER WIRE ONLY,
SUITABLE FOR AT LEAST 90°C
(194°F).

2) FOR REFERENCE: ALL
INTERNAL WIRING IS #12 GA.

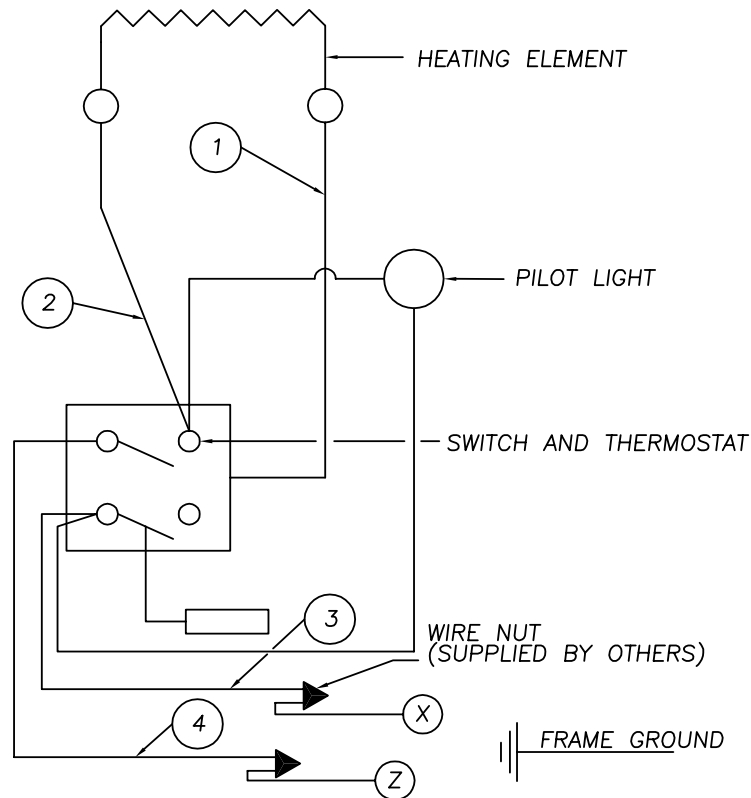

SINGLE PHASE CONNECTION



STAR MANUFACTURING INTERNATIONAL INC.
#10 SUNNEN DRIVE, ST. LOUIS, MO. 63143, USA

MATERIAL

MODEL NO.

PART NO.

524TG/CHS

SK 1896

FINISH

TITLE WIRING DIAGRAM 24" ELEC. GRIDDLE

DR. PMR

CK.

DATE 5/21/02

REVISIONS

LTR

DATE

DESCRIPTION OF CHANGE

DR

TOLERANCES UNLESS OTHERWISE NOTED
FRACTIONS $\pm 1/64$ DECIMALS ± 0.005 ANGLES $\pm 1^\circ$

THIS DRAWING CONTAINS INFORMATION CONFIDENTIAL TO STAR MFG. INT'L. INC.
NO REPRODUCTION OR DISCLOSURE OF ITS CONTENTS IS PERMITTED.

NOMINAL AMPS PER LINE WIRE

208V-3 PHASE

240V-3PHASE

208V

240V

6008 WATTS

8000 WATTS

1 PH

1 PH

X

Y

Z

X

Y

Z

FOR SUPPLY CONNECTIONS USE
GAUGE SHOWN OR LARGER

14.44

24.98

14.44

16.66

28.86

16.66

28.88

33.3

AWG
#16

AWG
#12

AWG
#16

AWG
#14

AWG
#10

AWG
#14

#10

AWG
#8

NOTE:

1) FOR SUPPLY CONNECTIONS USE
COPPER WIRE ONLY, SUITABLE FOR
AT LEAST 90°C (194°F).

2) FOR REFERENCE: ALL INTERNAL
WIRING IS #12 GA.

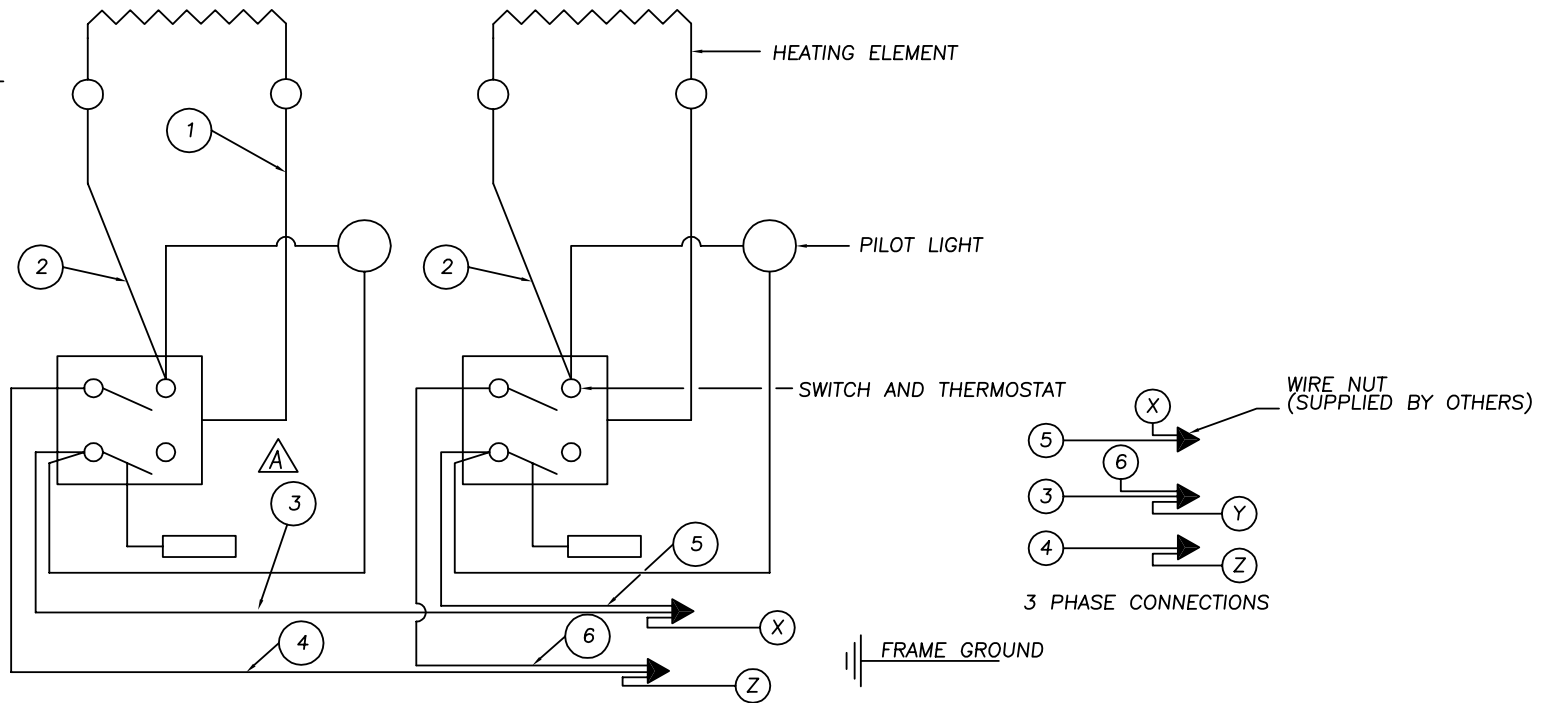

SINGLE PHASE CONNECTIONS



STAR MANUFACTURING INTERNATIONAL INC.
#10 SUNNEN DRIVE, ST. LOUIS, MO. 63143, USA

MATERIAL

MODEL NO.
536TG/CHS

PART NO.
SK 1897

FINISH

TITLE **WIRING DIAGRAM 36" ELEC. GRIDDLE**

DR. **PMR**

CK.

DATE **5/21/02**

REVISIONS

LTR

DATE

DESCRIPTION OF CHANGE

DR

TOLERANCES UNLESS OTHERWISE NOTED
FRACTIONS $\pm 1/64$ DECIMALS $\pm .005$ ANGLES $\pm 1^\circ$

THIS DRAWING CONTAINS INFORMATION CONFIDENTIAL TO STAR MFG. INT'L. INC.
NO REPRODUCTION OR DISCLOSURE OF ITS CONTENTS IS PERMITTED.

NOMINAL AMPS PER LINE WIRE					
208V-3 PHASE			240V-3PHASE		
9,012 WATTS			12,000 WATTS		
X	Y	Z	X	Y	Z
25.0	25.0	25.0	28.9	28.9	28.9
AWG #12			AWG #10		

NOTE:

- FOR SUPPLY CONNECTIONS USE COPPER WIRE ONLY, SUITABLE FOR AT LEAST 90°C (194°F).
- FOR REFERENCE: ALL INTERNAL WIRING IS #12 GA.

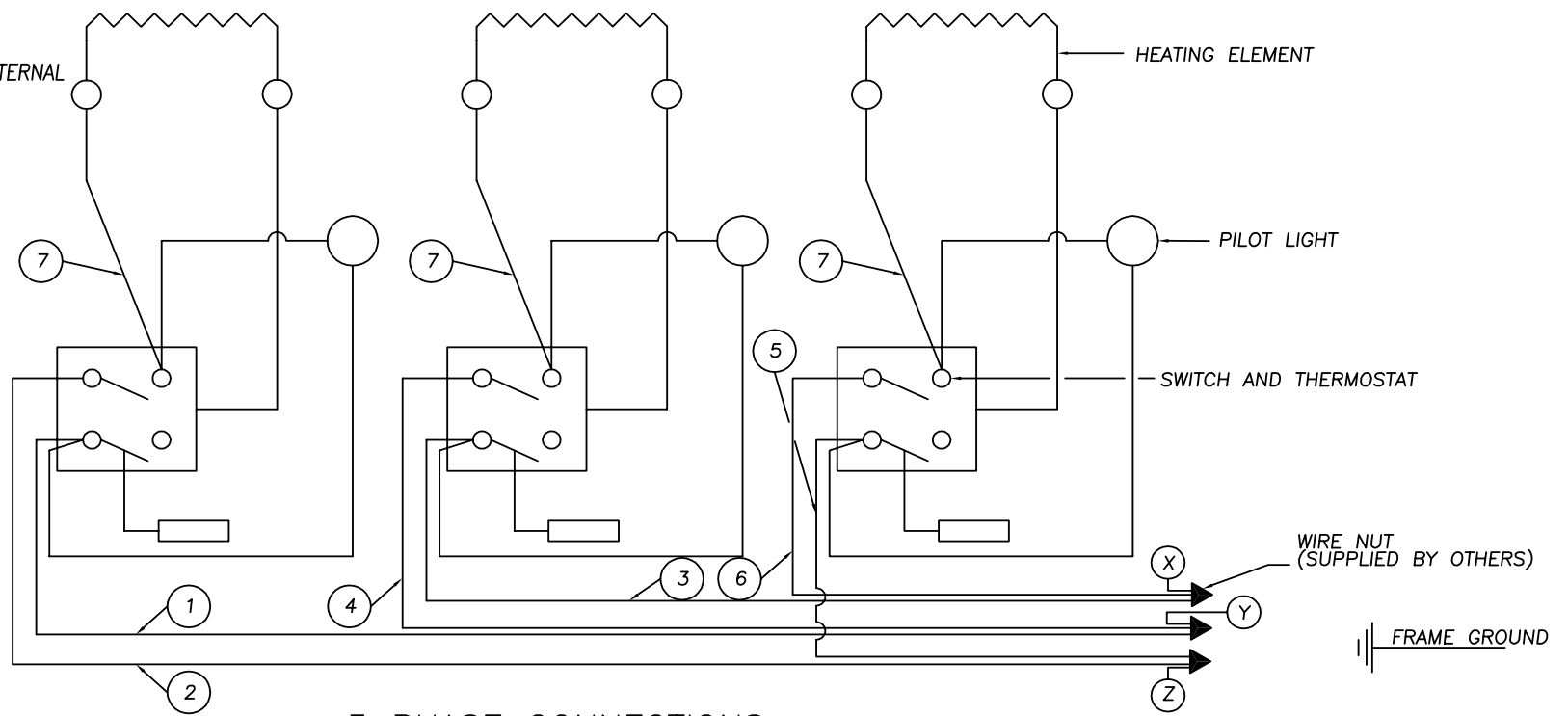

3 PHASE CONNECTIONS



STAR MANUFACTURING INTERNATIONAL INC.
#10 SUNNEN DRIVE, ST. LOUIS, MO. 63143, USA

MATERIAL

MODEL NO.

548TG/CHS

PART NO.

SK 1898

FINISH

TITLE WIRING DIAGRAM 48" ELEC. GRIDDLE

DR. PMR CK. DATE 5/21/02

REVISIONS	LTR	DATE	DESCRIPTION OF CHANGE	DR
		9-20-00	REDRAWN ON CAD	SO
	B	11/13/02	SUPPLY CONNECTIONS WERE NOT TRANSFERRED CORRECTLY WHEN REDRAWN ON CAD. CORRECTED TO 208V, 1 PH, IS #4 AWG. 240V, 1 PH, IS #4 AWG.	PR

TOLERANCES UNLESS OTHERWISE NOTED
FRACTIONS ±1/64 DECIMALS ±.005 ANGLES ±1'

THIS DRAWING CONTAINS INFORMATION CONFIDENTIAL TO STAR MFG. INT'L. INC.
NO REPRODUCTION OR DISCLOSURE OF ITS CONTENTS IS PERMITTED.

NOMINAL AMPS PER LINE WIRE

208V-3 PHASE		240V-3PHASE			208V	240V	
12,016 WATTS		16,000 WATTS			1 PH	1 PH	
X	Y	Z	X	Y	Z		
38.2	24.99	38.2	44.18	28.9	44.18	57.8	66.7
AWG #6	AWG #8	AWG #6	AWG #6	AWG #10	AWG #6	AWG #4	AWG #4

FOR SUPPLY CONNECTIONS,
USE GAUGE SHOWN OR
LARGER.

NOTE:

1) FOR SUPPLY CONNECTIONS USE
COPPER WIRE ONLY, SUITABLE FOR
AT LEAST 90°C (194°F).

2) FOR REFERENCE: ALL INTERNAL
WIRING IS #12 GA.

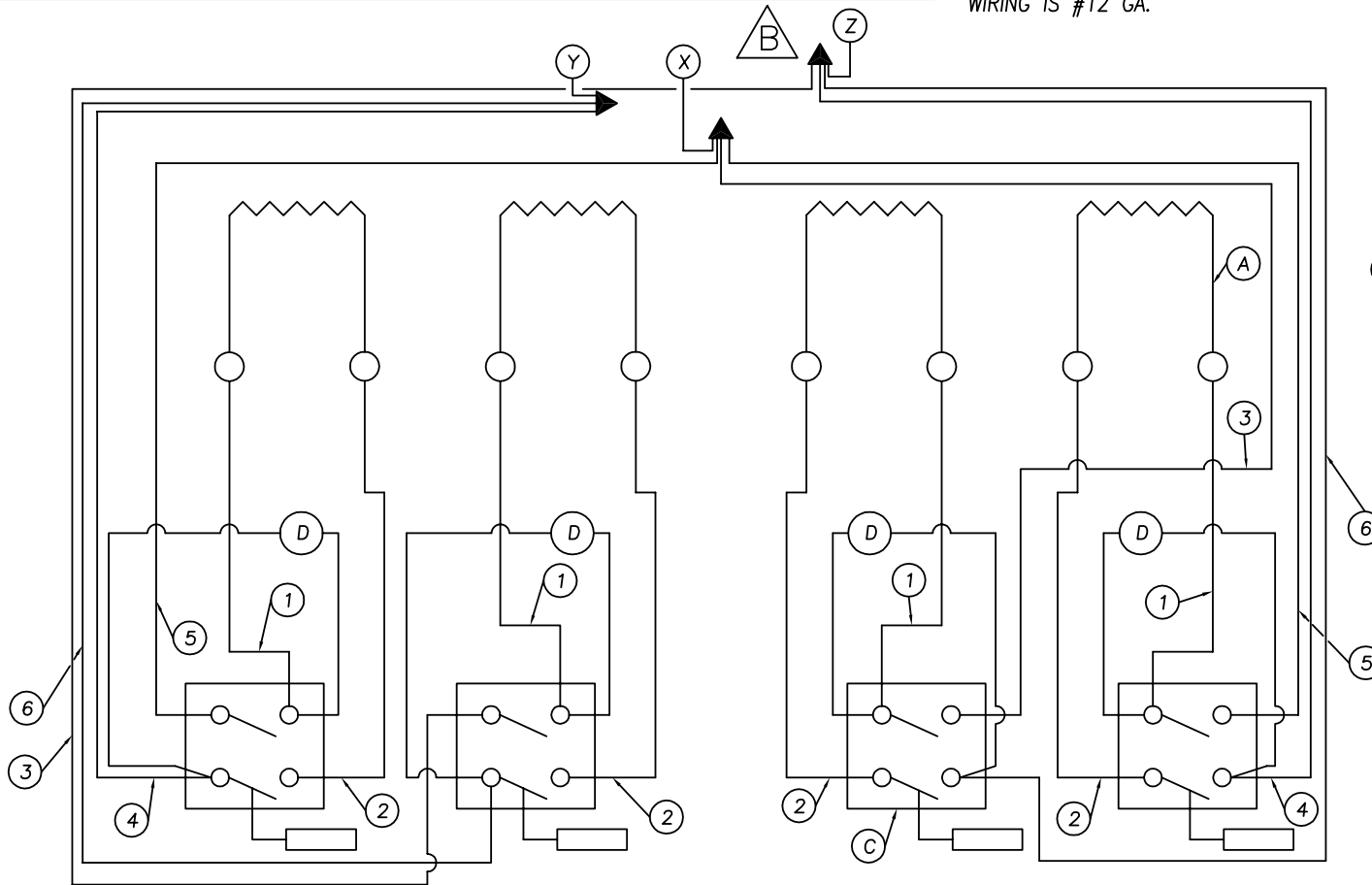

3 PHASE CONNECTIONS

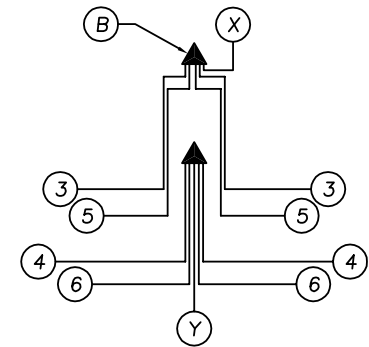

SINGLE PHASE CONNECTION

- (A) HEATING ELEMENT
- (B) WIRE NUT (SUPPLIED BY OTHERS)
- (C) SWITCH & THERMOSTAT
- (D) PILOT LIGHT

||| FRAME GROUND